

THIS DRAWING IS UNPUBLISHED. RELEASED FOR PUBLICATION MAR ,2011.
 © COPYRIGHT 2011 By Tyco Electronics Japan G.K. ALL RIGHTS RESERVED.

LOC		DIST		REVISIONS			
J	-	P	LTR	DESCRIPTION	DATE	DWN	APVD
		B2	REVISED		FEB.17'16	J.W	S.L

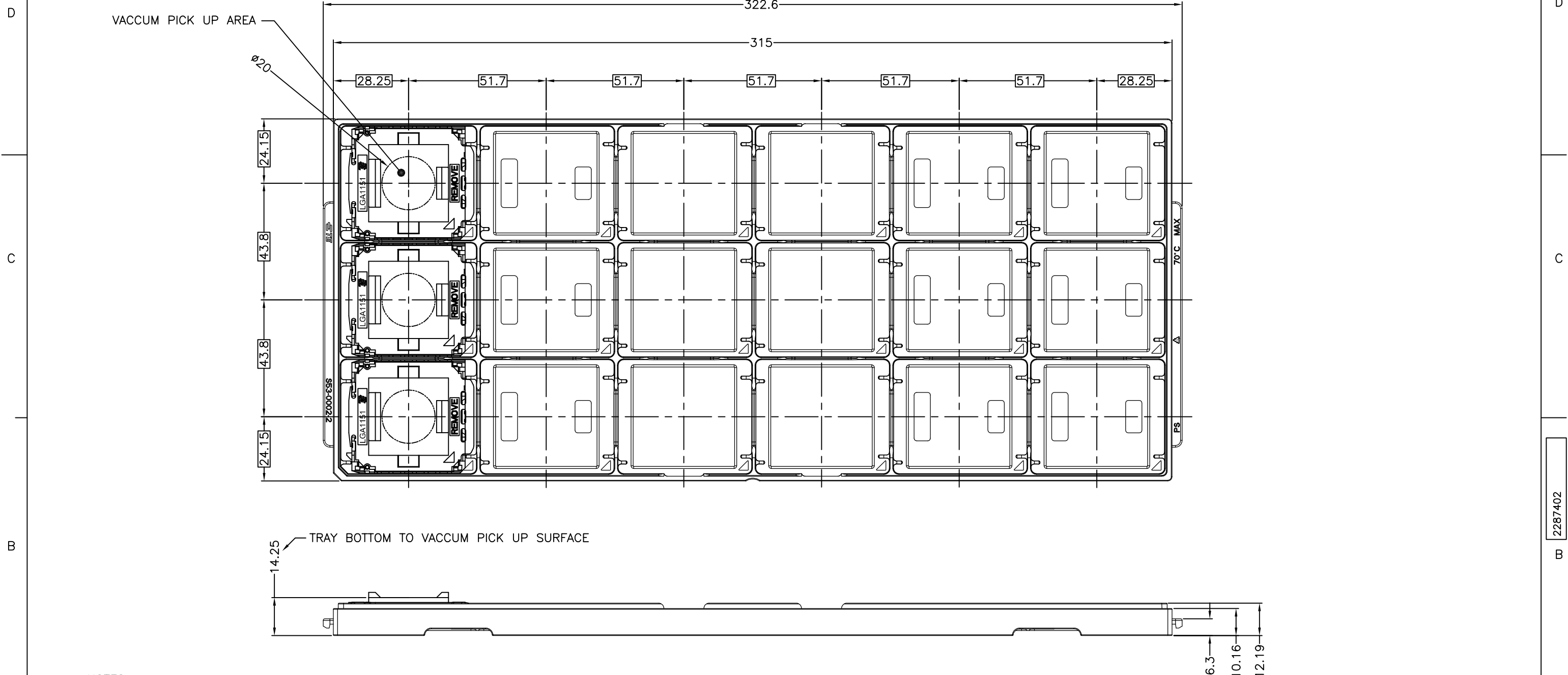

- NOTES:
- MATERIAL
 - HOUSING : LCP, HIGH TEMP, THERMO-PLASTIC, UL94V-0, BLACK
 - CONTACT : COPPER ALLOY
FINISH : Au PL. AT CONTACT AREA ON OVERALL OVER Ni UNDER PL. 0.00127 MIN.
 - SOLDER BALL : Sn/Ag/Cu
 - CAP : LCP, HIGH TEMP. THERMO-PLASTIC, UL94V-0, BLACK
 - INDICATED DATE CODE ON THE HSG

2287402-1,-2,-3: AS SHOWN

2287402-3	18	0.76 um MIN Au PL
2287402-2	18	G/F Au PL
2287402-1	18	0.38 um MIN Au PL
PART NUMBER	SOCKET QTY PRE TRAY	DESCRIPTION

THIS DRAWING IS A CONTROLLED DOCUMENT.

DWN	NOV.'2014	JEFF WANG	 TE Connectivity
CHK	NOV.'2014	MURRAY LU	
APVD	NOV.'2014	SIMON LI	NAME
PRODUCT SPEC 製品規格 108-78586			SOCKET ASSY LGA1151
APPLICATION SPEC 取得適用規格 114-5444			SIZE
WEIGHT	9.8g	A2	CAGE CODE
CUSTOMER DRAWING		00779	DRAWING NO
		C=2287402	RESTRICTED TO
		SCALE 1:1	SHEET 1 of 6
		REV B2	

THIS DRAWING IS UNPUBLISHED. RELEASED FOR PUBLICATION MAR , 2011.
 © COPYRIGHT 2011 By Tyco Electronics Japan G.K. ALL RIGHTS RESERVED.

LOC	DIST	REVISIONS					
J	-	P	LTR	DESCRIPTION	DATE	DWN	APVD
		-	-	SEE SHEET 1	-	-	-

D

C

B

A

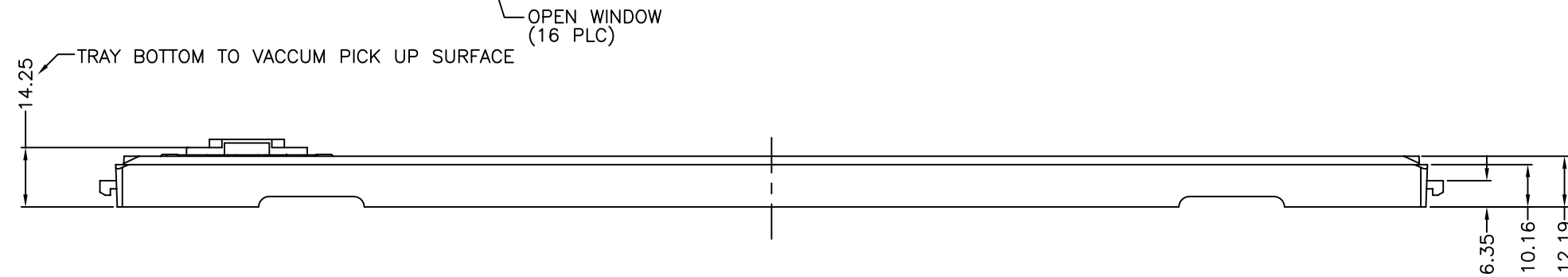
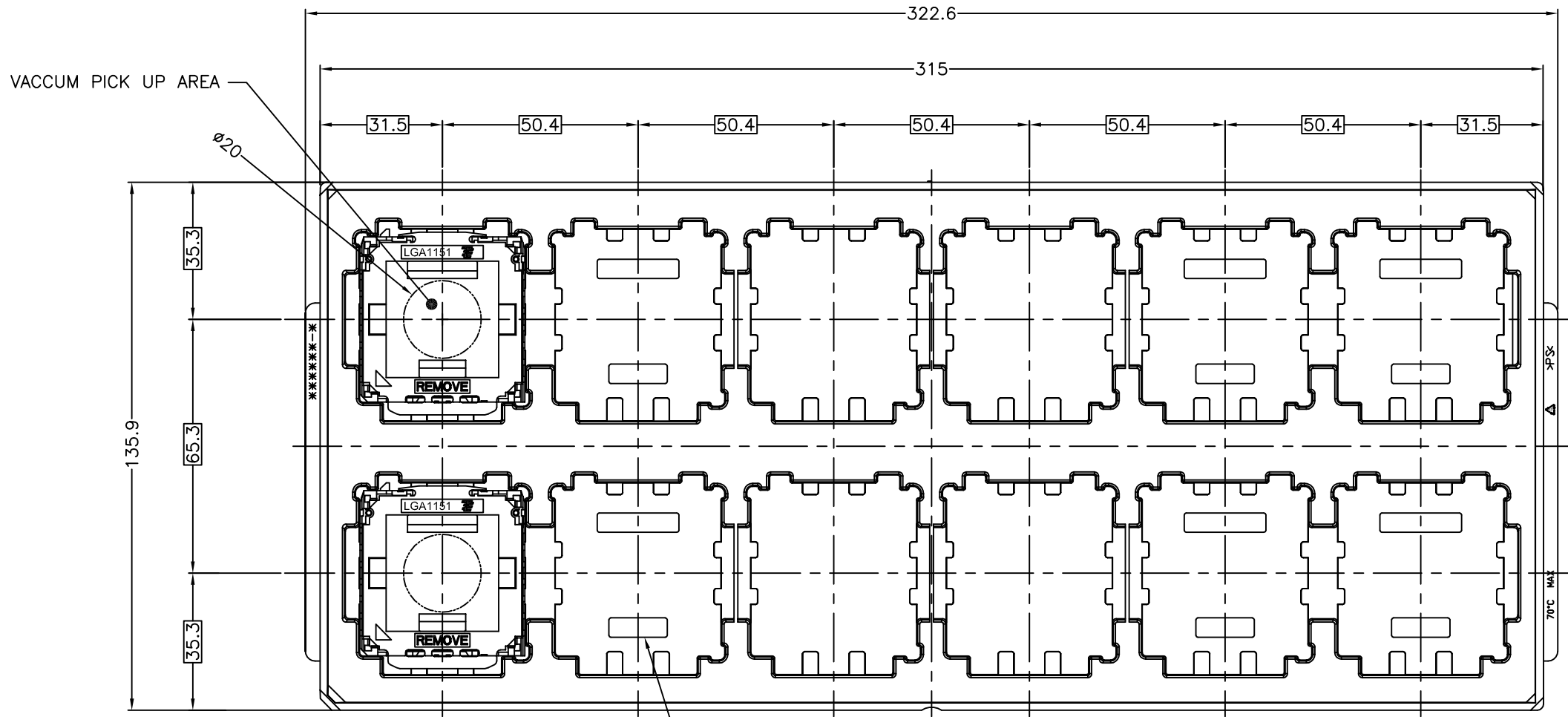

1-2287402-1,-2,-3: AS SHOWN

1-2287402-3	12	0.76 um MIN Au PL
1-2287402-2	12	G/F Au PL
1-2287402-1	12	0.38 um MIN Au PL
PART NUMBER	SOCKET QTY PRE TRAY	DESCRIPTION

THIS DRAWING IS A CONTROLLED DOCUMENT.

DWN	NOV.'2014	JEFF WANG	
CHK	NOV.'2014	MURRAY LU	
APVD	NOV.'2014	SIMON LI	
PRODUCT SPEC	108-78586	NAME	SOCKET ASSY LGA1151
APPLICATION SPEC	114-5444	SIZE	A2
WEIGHT	9.8g	CAGE CODE	00779
CUSTOMER DRAWING	SCALE	DRAWING NO	REV
	1:1	C=2287402	B2

TE Connectivity

RESTRICTED TO

1471-9 (3/11)

D

C

B

A

2287402

4

3

2

1

THIS DRAWING IS UNPUBLISHED. RELEASED FOR PUBLICATION
 © COPYRIGHT - By Tyco Electronics Japan G.K. ALL RIGHTS RESERVED.

LOC		DIST		REVISIONS			DATE	DWN	APVD
P	LTR	DESCRIPTION							
-	-	SEE SHEET 1			-	-	-	-	-

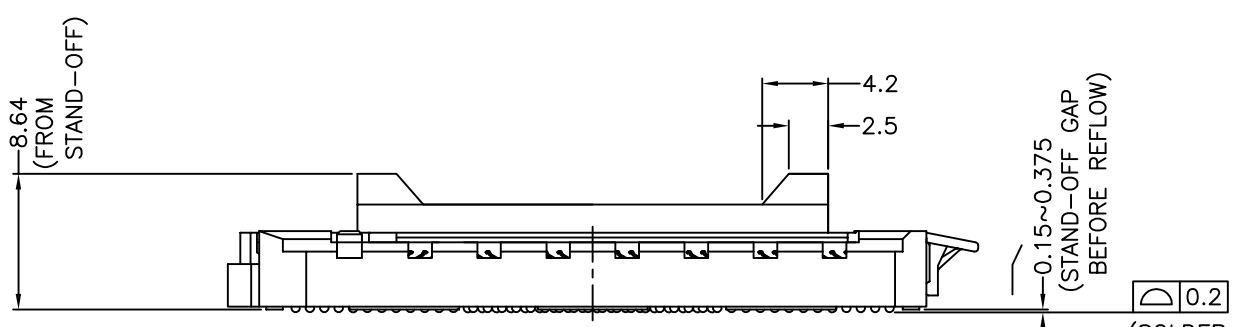
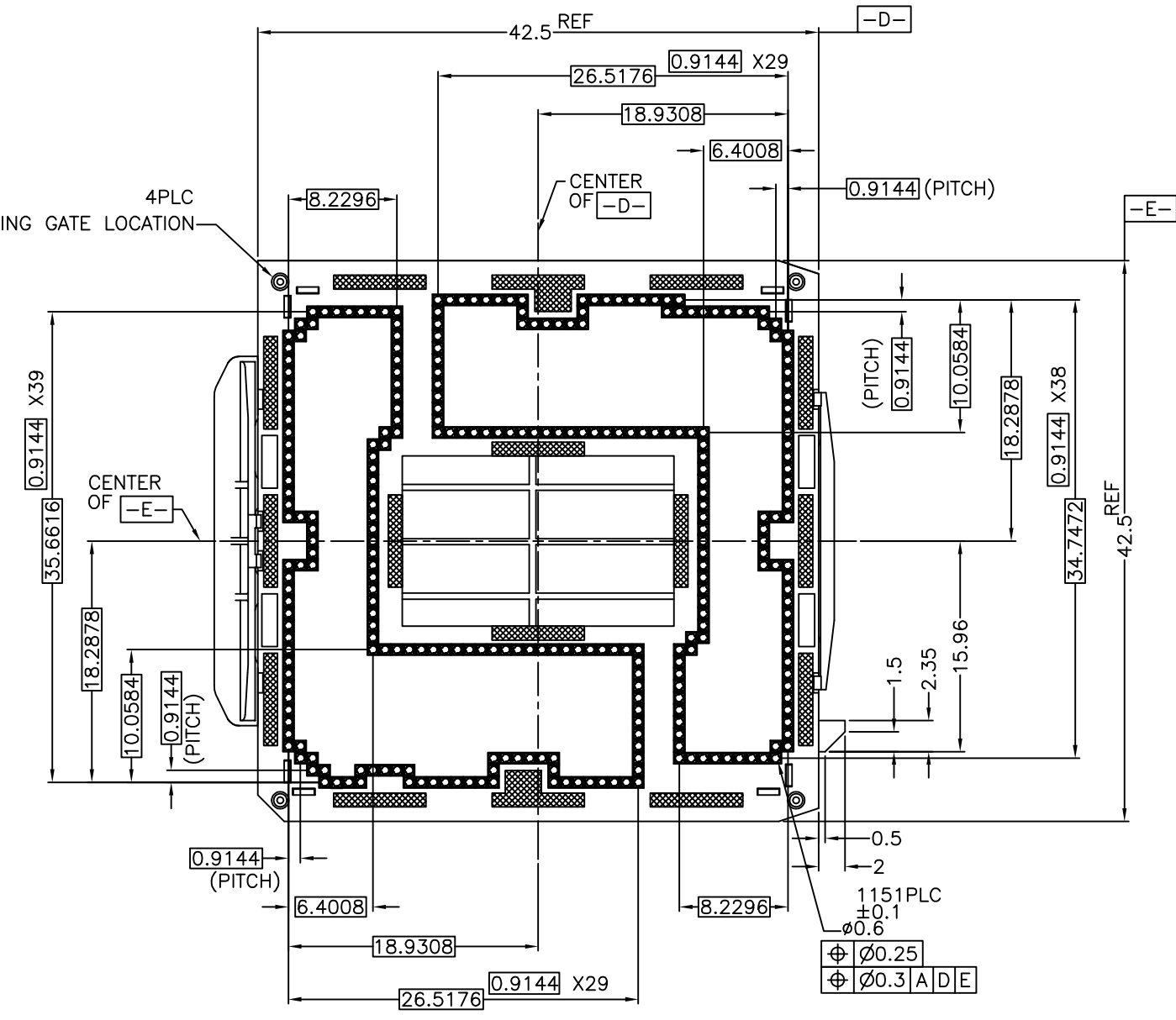
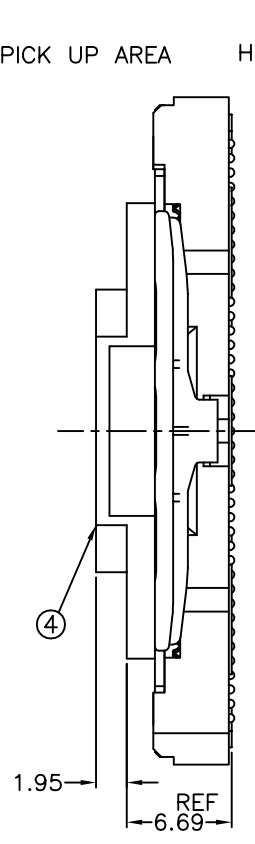
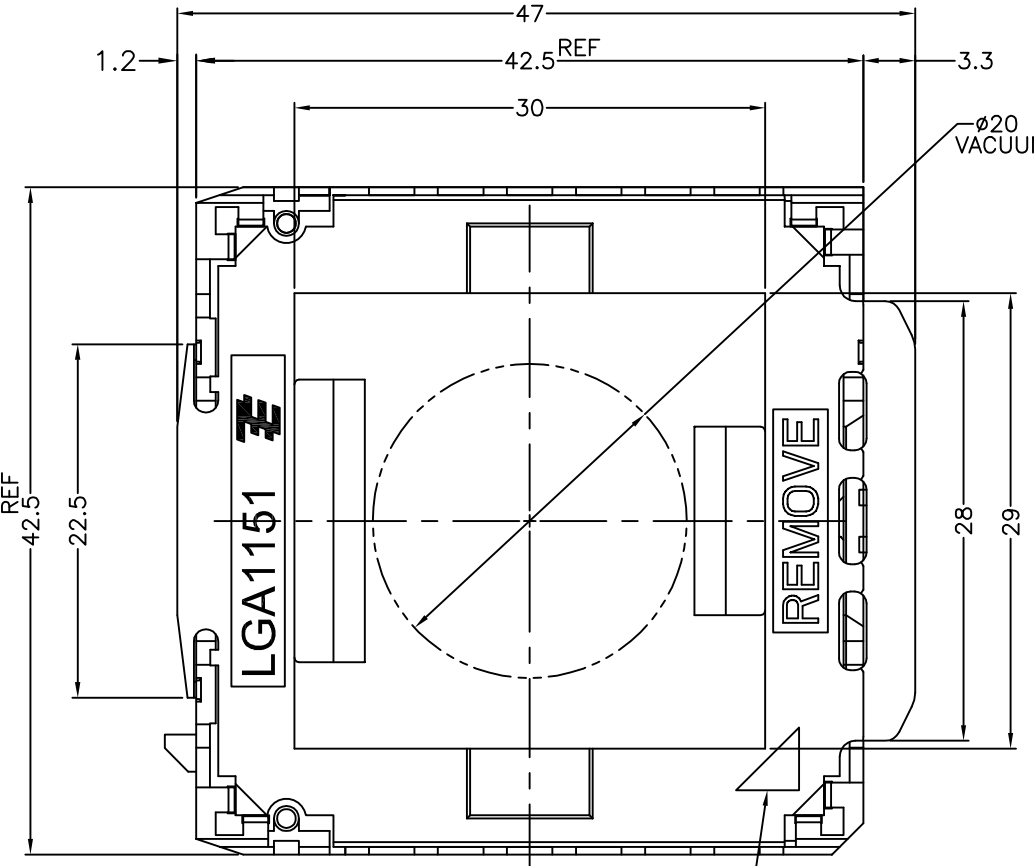
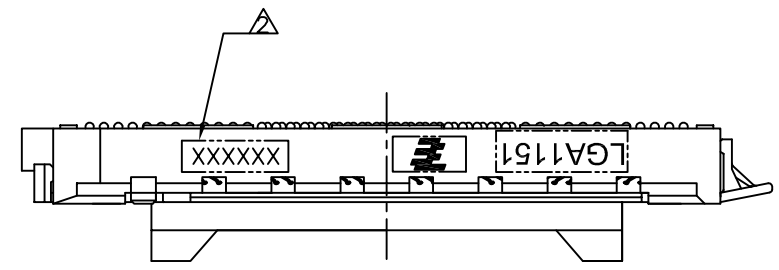

2287402-*, 1-2287402-*: AS SHOWN

THIS DRAWING IS A CONTROLLED DOCUMENT.		DWN	TE Connectivity	
DIMENSIONS: 単位: 寸 mm		CHK	NAME 名称	
TOLERANCES UNLESS OTHERWISE SPECIFIED: 一般公差		APVD	SOCKET ASSY LGA1151	
0-PLC ±0.3		PRODUCT SPEC 製品規格	SIZE A2	CAGE CODE 00779
1-PLC ±		APPLICATION SPEC 取付適用規格	DRAWING NO 番号 C=2287402	RESTRICTED TO
2-PLC ±		WEIGHT	SCALE 尺度 NTS	SHEET 3 of 6
3-PLC ±		CUSTOMER DRAWING	REV B2	
4-PLC ±				
ANGLES				
FINISH 仕上				

LOC		DIST		REVISIONS			DATE	DWN	APVD
		P	LTR	DESCRIPTION					
		-	-	SEE SHEET 1			-	-	-

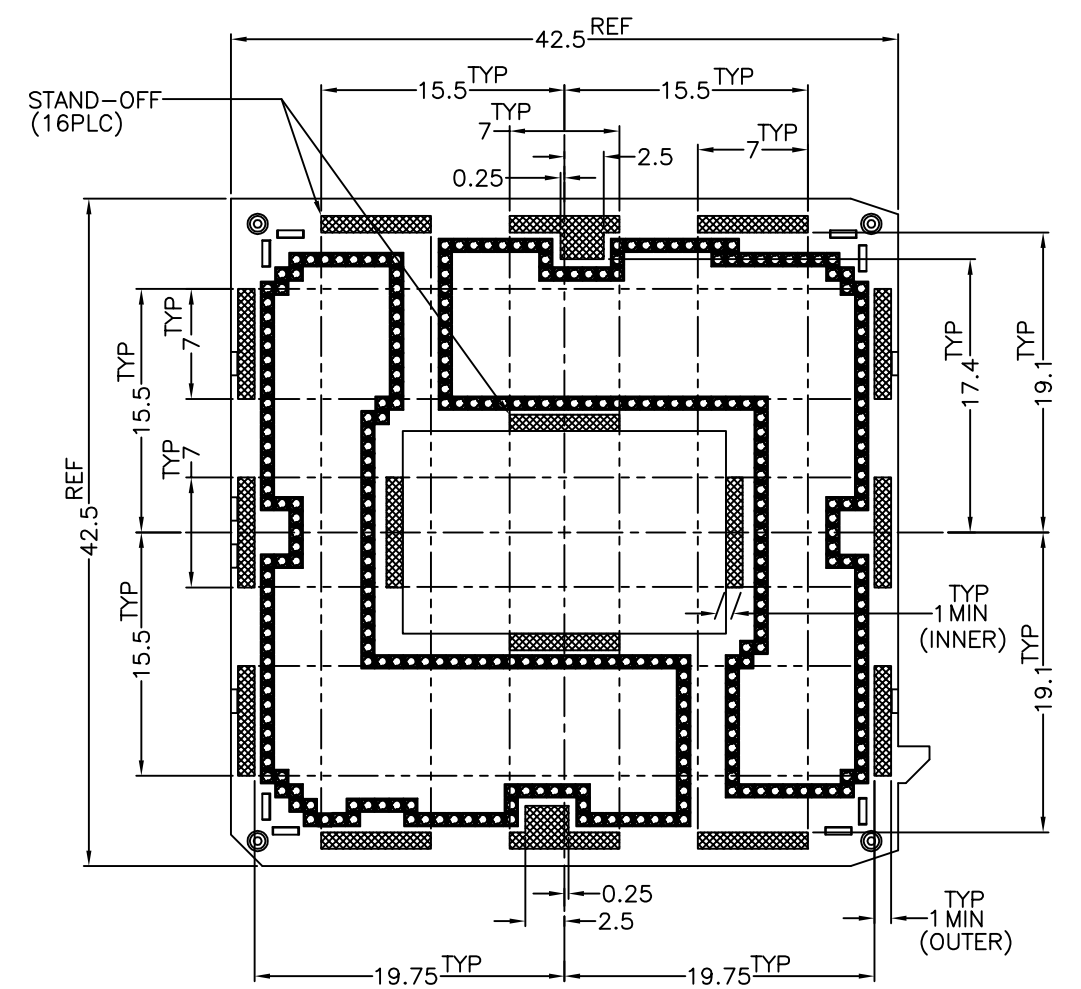
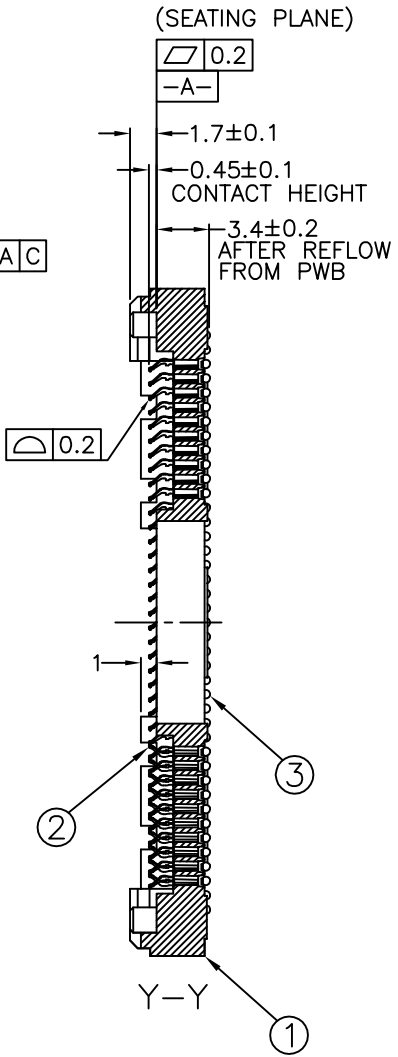
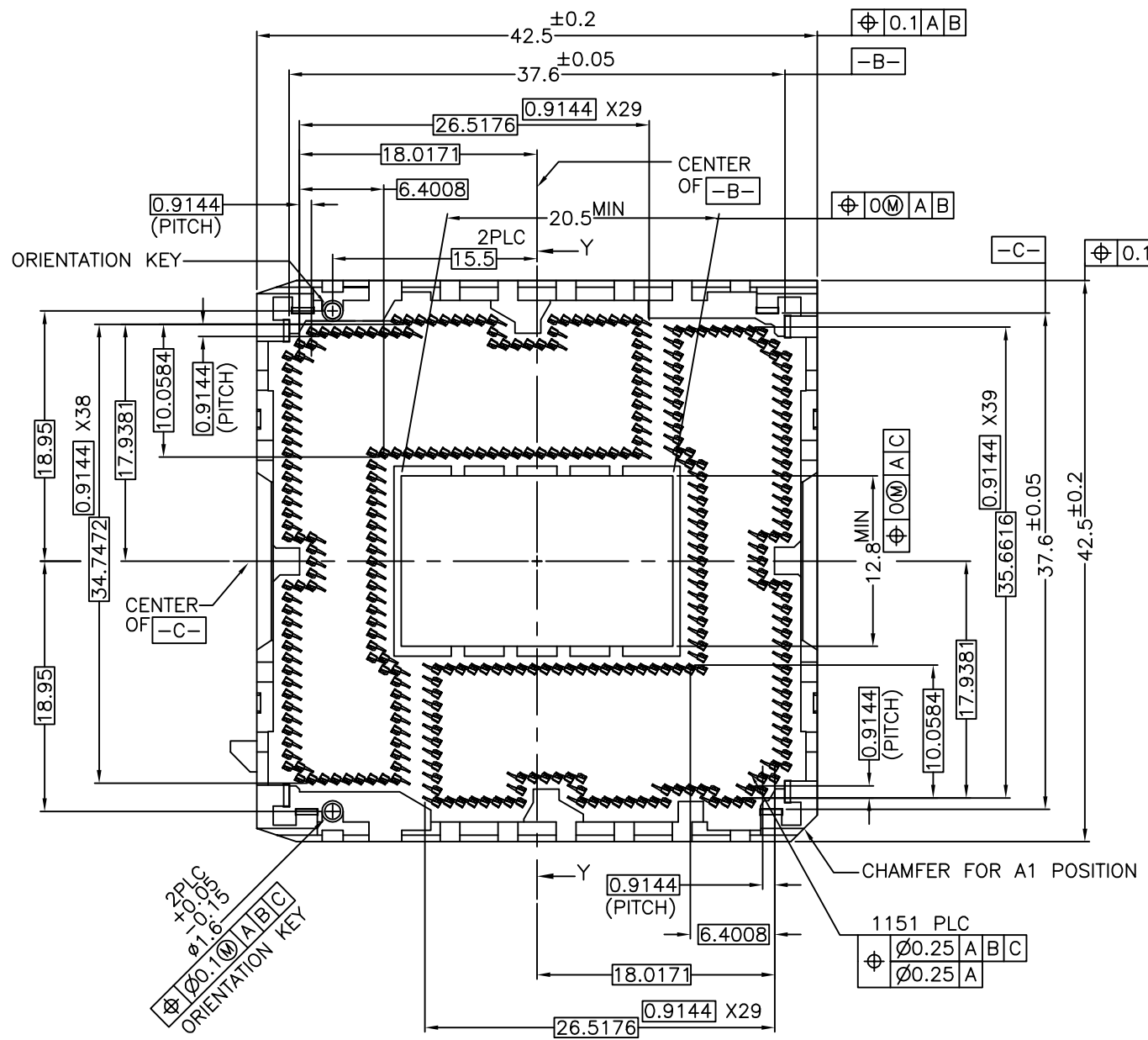

2287402-*, 1-2287402-*: AS SHOWN

THIS DRAWING IS A CONTROLLED DOCUMENT.		DWN			TE Connectivity	
DIMENSIONS: 単位: 寸 mm		CHK			NAME 名称	
TOLERANCES UNLESS OTHERWISE SPECIFIED: 一般公差		APVD	PRODUCT SPEC 製品規格		SIZE	A2
0-PLC ±0.3 1-PLC ±0.3 2-PLC ±0.3 3-PLC ±0.3 4-PLC ±0.3 ANGLES 寸上		APPLICATION SPEC 取付適用規格	DRAWING NO 番号		CAGE CODE	00779
MATERIAL 材料		WEIGHT	DRAWING NO 番号		DRAWING NO	C-2287402
		CUSTOMER DRAWING	SCALE 尺度		NTS	SHEET 4 of 6
			REV		B2	

2287402

4

3

2

1

THIS DRAWING IS UNPUBLISHED. RELEASED FOR PUBLICATION
 © COPYRIGHT - By Tyco Electronics Japan G.K. ALL RIGHTS RESERVED.

LOC		DIST		REVISIONS			DATE	DWN	APVD
P	LTR	DESCRIPTION							
-	-	SEE SHEET 1			-	-	-	-	-

D

C

B

A

REFERENCE PATTERN LAYOUT

REFERENCE PATTERN LAYOUT

FOR GENERAL BOARD DESIGN, PLEASE REFER TO THE THERMAL AND MECHANICAL DESIGN GUIDELINES(TMDG) PROVIDED BY INTEL CORPORATION

ILM ASSEMBLY OCCUPATION AREA (REFERENCE)
 CAP IS NOT SHOWN ON THIS VIEW

ILM ASSEMBLY OCCUPATION AREA (REFERENCE)
 CAP IS NOT SHOWN ON THIS VIEW

D

C

B

A

2287402

THIS DRAWING IS A CONTROLLED DOCUMENT.		DWN	TE Connectivity	
DIMENSIONS: 単位: 寸 mm		CHK	NAME 名称	
TOLERANCES UNLESS OTHERWISE SPECIFIED: 一般公差		APVD	PRODUCT SPEC 製品規格	
0-PLC ±0.3		APPLICATION SPEC 取付適用規格		RESTRICTED TO
1-PLC ±0.3		SIZE	CAGE CODE	DRAWING NO 番号
2-PLC ±0.3		A2	00779	C=2287402
3-PLC ±0.3		WEIGHT		REV
4-PLC ±0.3		CUSTOMER DRAWING		B2
ANGLES		SCALE 尺度		SHEET
FINISH 仕上		NTS		5 of 6

1471-9 (3/11)

Downloaded From Oneyac.com

LOC	DIST	REVISIONS					
		P	LTR	DESCRIPTION	DATE	DWN	APVD
-	-	-	-	SEE SHEET 1	-	-	-

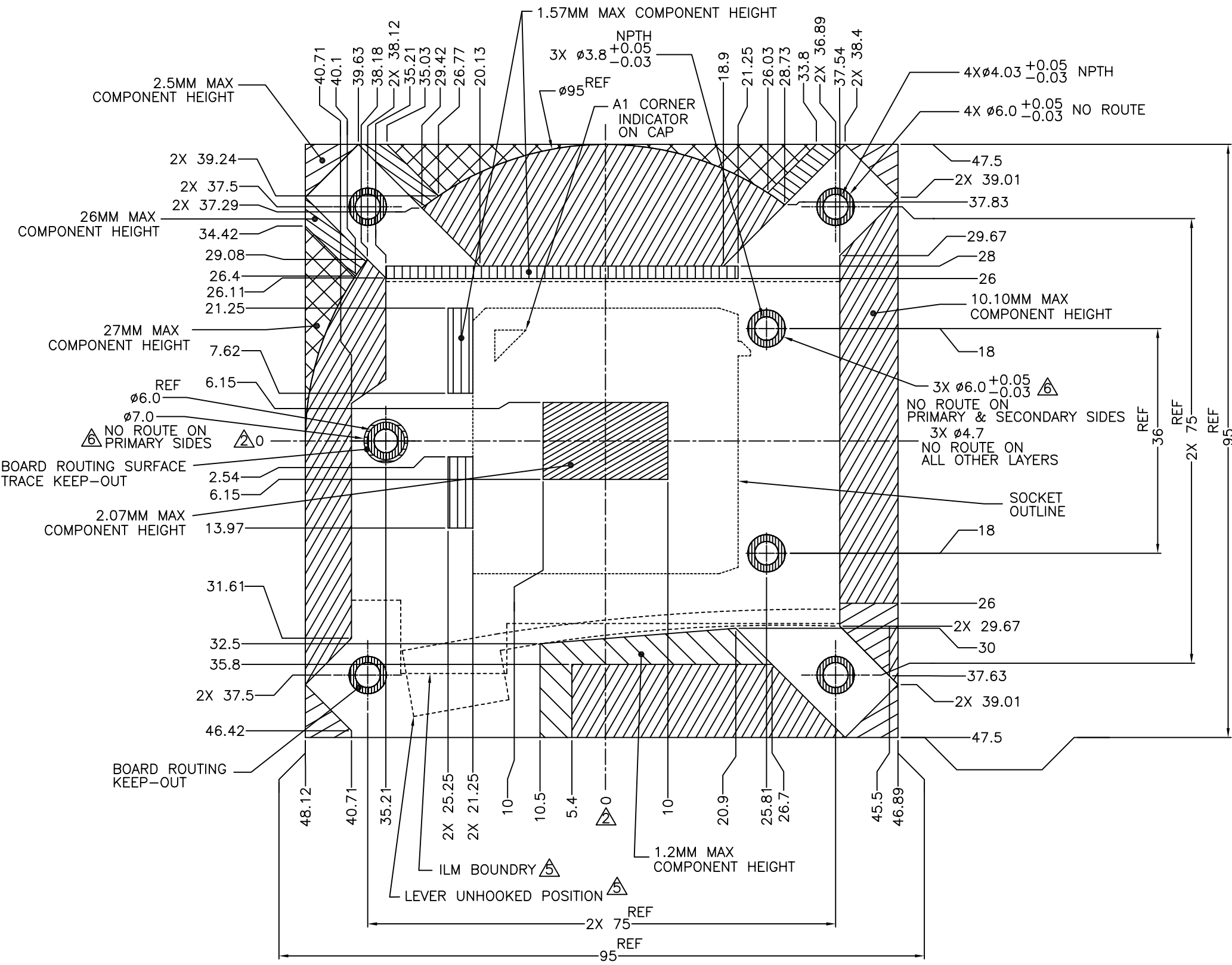

- NOTES (APPLIED TO SHEET 5 OF 5):
1. DIMENSIONS ARE IN MILLIMETERS
 2. \triangle GEOMETRIC CENTER OF SOCKET HOUSING CAVITY
 3. BOARD COMPONENT KEEP-INS AND MECHANICAL COMPONENT KEEP-OUTS TO BE UTILIZED WITH SUFFICIENT ALLOWANCES FOR PLACEMENT AND SIZE TOLERANCES, ASSEMBLY PROCESS ACCESS, AND DYNAMIC EXCURSIONS.
 4. ASSUME SYMMETRY FOR UNDIMENSIONED CORNERS AND EDGES. FOR UNDEFINED DIMENSIONS, REFER TO THERMAL AND MECHANICAL DESIGN GUIDELINE PROVIDED BY INTEL CORPORATION.
 5. \triangle COPPER PAD ON PRIMARY SIDE, NON-GROUNDED. COPPER PAD CAN INSET A MAXIMUM OF 0.127MM FROM THE NO ROUTE EDGE
 6. \triangle COMBINED COMPONENT AND SOLDER PASTE HEIGHT INCLUDING TOLERANCES AFTER REFLOW.

COMPONENT KEEP-INS AND MECHANICAL COMPONENT KEEP-OUTS
 FOR REFERENCE ONLY, PLEASE REFER TO THE THERMAL AND MECHANICAL
 DESIGN GUIDELINES(TMDG) PROVIDED BY INTEL CORPORATION

LEGEND	
	SOCKET/THERMAL/MECHANICAL COMPONENT KEEP-INS
	10.10MM MAX COMPONENT HEIGHT \triangle
	1.57MM MAX COMPONENT HEIGHT \triangle
	1.2MM MAX COMPONENT HEIGHT \triangle
	BOARD ROUTING KEEP-OUT
	27MM MAX COMPONENT HEIGHT \triangle
	BOARD ROUTING SURFACE TRACE KEEP-OUT \triangle
	2.07MM MAX COMPONENT HEIGHT \triangle
	2.5MM MAX COMPONENT HEIGHT \triangle
	26MM MAX COMPONENT HEIGHT \triangle

THIS DRAWING IS A CONTROLLED DOCUMENT.

DIMENSIONS: 単位: 寸 mm	TOLERANCES UNLESS OTHERWISE SPECIFIED: 一般公差	DWN	TE Connectivity
	0-PLC ± 1-PLC ± 2-PLC ± 3-PLC ± 4-PLC ± ANGLES ±	CHK	NAME
MATERIAL 材料	FINISH 仕上	APVD	SOCKET ASSY LGA1151
		PRODUCT SPEC 製品規格	SIZE CAGE CODE DRAWING NO 番号
		APPLICATION SPEC 取付適用規格	A2 00779 C-2287402
		WEIGHT	RESTRICTED TO
		CUSTOMER DRAWING	SCALE 尺度 NTS SHEET 6 of 6 REV B2

单击下面可查看定价，库存，交付和生命周期等信息

[>>TE Connectivity\(泰科\)](#)