

LOC	DIST	REV	DATE	BY	APPV
A	66				
		REVISIONS			
		DESCRIPTION	DATE	BY	APPV
		SEE SHEET 1			

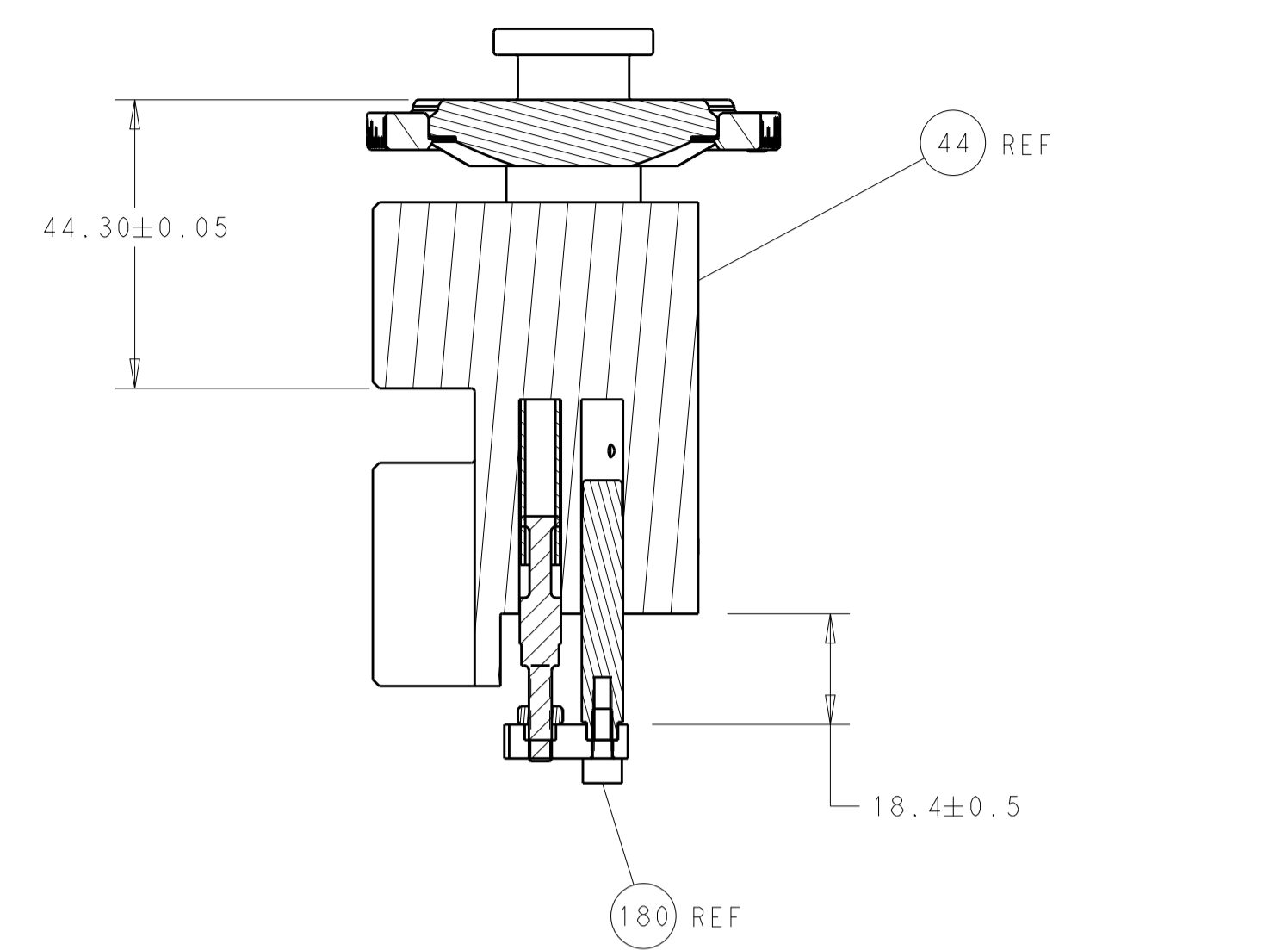

RAM AND HOLDDOWN SET-UP

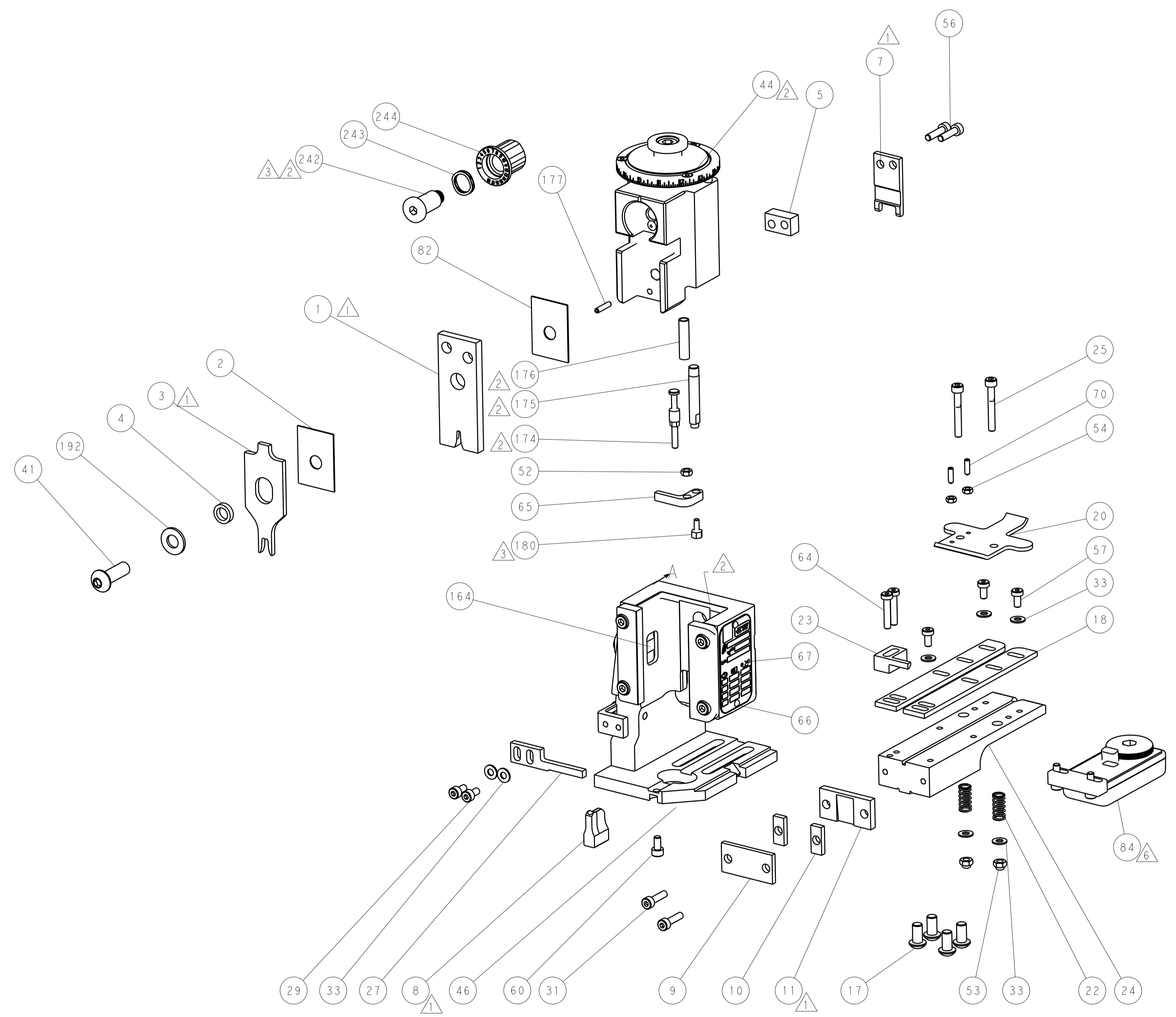

FEED TYPE

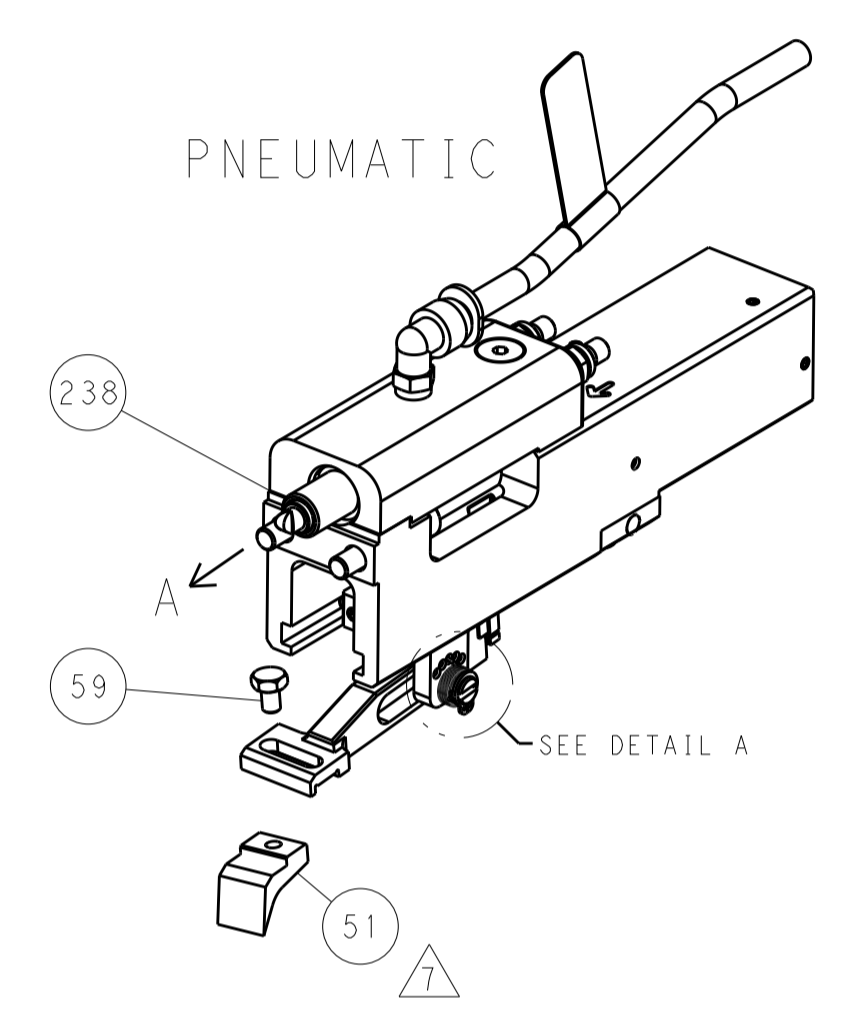

PNEUMATIC

FEED SPRING SETTING POSITION

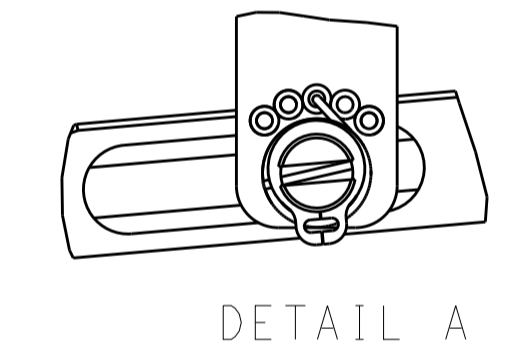

CAM POSITION

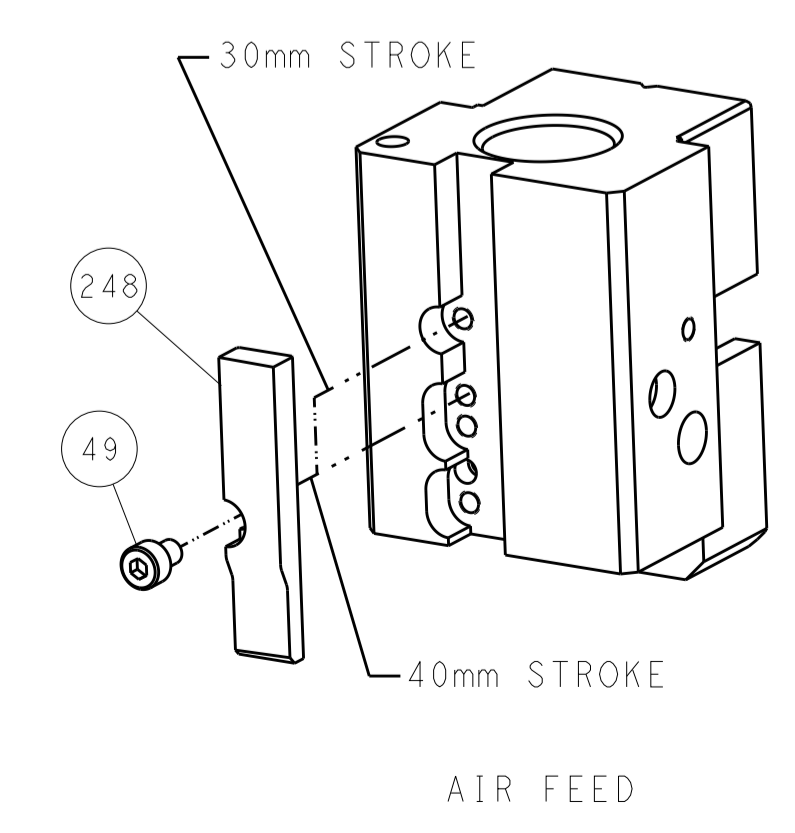

AIR FEED

ATLANTIC VERSION
 Shown on sheets 1 of 4 & 2 of 4
 (Pacific version shown on sheets 3 of 4 & 4 of 4)

<small>THIS DRAWING IS UNPUBLISHED. RELEASED FOR PUBLICATION BY TYCO ELECTRONICS CORPORATION. ALL RIGHTS RESERVED.</small>		DWN: J. HOU 14JUL2016 CHK: L. ZHANG 14JUL2016 APVD: L. ZHANG 14JUL2016	TE Connectivity Harrisburg, PA 17105-3608
DIMENSIONS: mm TOLERANCES UNLESS OTHERWISE SPECIFIED: 0 PLC ± 1 PLC ± 2 PLC ± 3 PLC ± 4 PLC ± ANGLES ±		NAME: Ocean End Feed Applicator PRODUCT SPEC: APPLICATION SPEC: SIZE: A1 CAGE CODE: 00779 DRAWING NO: 2150696	RESTRICTED TO:
MATERIAL:		WEIGHT:	SCALE: 1:1 SHEET: 2 of 4 REV: E

PART NUMBER	REVISION	DESCRIPTION	FEED TYPE
2-2150696-2	E	FINE CRIMP HEIGHT ADJUST	PNEUMATIC
7-2150696-7	A	CRIMP TOOLING KIT	-

PACIFIC VERSION TERMINATOR
INTERFACE ADAPTER

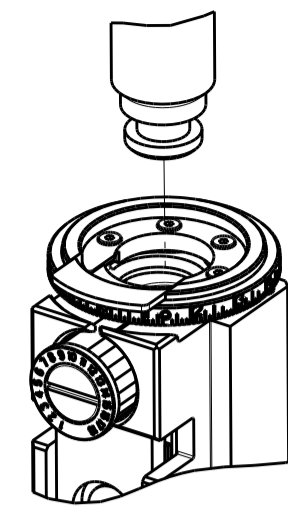

APPLICATOR DATA		
CRIMP	SIZE	TYPE
WIRE	2.54 mm (.100)	F
INSUL	4.57 mm (.180)	F
APPL INSTRUCTIONS 408-35043		

TERMINAL DATA: TE TERMINAL		TE CRIMP SPECIFICATION	
TERMINAL NAME: AMPLIVAR CLUSTER REC.			
WIRE STRIP LENGTH		INSULATION DIAMETER RANGE	
7.70-8.70 mm (.303-.343 IN)		1.30-3.50 mm (.051-.138 IN)	
TERMINAL APPLICATION SPECIFICATION	114-5215		
TERMINALS APPLIED			
TE TERMINAL	TE TERMINAL	TE TERMINAL	TE TERMINAL
316294-1			

WIRE SIZE	CRIMP HEIGHT mm [INCH]	CRIMP HEIGHT REFERENCE SETTING
18 & 21 MAG WIRE	1.64 +/- 0.05 [0.065 +/- .002]	7.7
18.5 & 21.5 MAG WIRE	1.55 +/- 0.05 [0.061 +/- .002]	8.7
19 MAG WIRE	1.45 +/- 0.05 [0.057 +/- .002]	9.4
21 MAG WIRE	1.36 +/- 0.05 [0.054 +/- .002]	10.3

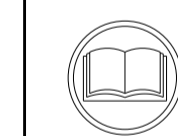

- 1 RECOMMENDED SPARE PARTS
- 2 REFER TO SUPPLIED INSTRUCTION SHEET FOR CLEANING, LUBRICATION AND STORAGE OF APPLICATOR.
- 3 APPLY PART NUMBER 1-23419-5 LOCTITE TO THREADS OF ITEMS 180. APPLY PART NUMBER 2-23419-6 LOCTITE TO THREADS OF ITEM 242.
- 4 CRIMP HEIGHT REFERENCE SETTING WAS THE SETTING USED WHEN THE APPLICATOR WAS QUALIFIED AT THE FACTORY. ADJUSTMENT MAY BE NECESSARY WHEN RUNNING APPLICATOR IN THE FIELD.
- 5 TERMINAL PITCH NOT COMPATIBLE WITH MECHANICAL FEED.
- 6 TERMINAL LUBRICANT IS RECOMMENDED.
- 7 POSITION ITEM 51 TO FEED TERMINAL FROM THE RECEPTACLE.
- 8. UNLESS SPECIFIED OTHERWISE TORQUE VALUES SHALL BE USED PER DOCUMENT, 101-35000.

***WARNING**
ON INSTALLATION, SET WIRE DISC TO CRIMP HEIGHT REFERENCE SETTING FOR LARGEST WIRE SIZE. CRIMP HEIGHT REFERENCE SETTINGS GREATER THAN THE VALUE SHOWN MAY CAUSE DAMAGE TO THE CRIMP TOOLING. REFER TO THE INSTRUCTION SHEET FOR PROPER SETUP AND ADJUSTMENTS.

PACIFIC VERSION
Shown on sheets 3 of 4 & 4 of 4
(Atlantic version shown on sheets 1 of 4 & 2 of 4)

LOC	DIST	REVISIONS					
A	66	P	LTN	DESCRIPTION	DATE	OWN	APVD
		-		SEE SHEET 1			

-	1	2119082-2	CAM, SNAIL, INSULATION ADJUSTMENT	244
-	1	2079764-1	WASHER, WAVE SPRING, CREST-TO-CREST	243
-	1	2119083-1	RETAINER, INSULATION DIAL	242
-	1	2844940-4	AIR FEED MODULE	238
-	1	1-18028-0	WASHER, FLAT, REG M8	192
-	4	2079383-9	SCR, BHSC, RoHS (M6 X 20)	186
-	1	4-1752354-1	STANDOFF, HOLD-DOWN	180
-	1	6-993111-6	PIN, SLOTTED SPRING 3.0 X 14.0	177
-	1	8-22280-7	SPRING, COMPRESSION	176
-	1	1752353-2	GUIDE PIN, HOLDDOWN	175
-	1	1901680-2	GUIDE PIN, HOLDDOWN	174
-	REF	994970-2	COUNTER, MAGNETIC	164
-	1	2119641-2	FEED CAM, AIR FEED	152
-	1	2168083-8	SCR, SKT HD CAP, RoHS, M4 X 16	144
-	1	2119655-6	APPLICATOR BASIC ASSEMBLY, EF	141
-	1	1803518-1	RAM ASSEMBLY, EF PACIFIC	140
-	1	2119955-2	ASSY, LUBRICATOR, END FEED	84
-	1	455888-6	SPACER, CRIMPER	82
-	1	1803607-4	DOCUMENTATION PACKAGE	71
-	2	2-18032-2	SCR, SET, FLT PNT, M3 X 10.0	70
-	1	2119740-1	TAG, IDENTIFICATION	67
-	2	2168078-1	SCREW, DRIVE, RH, RoHS, 2 x .188	66
-	1	1901681-2	HOLDDOWN, TERMINAL	65
-	2	2168400-5	SHCS, LOW HEAD, RoHS, M4 X 20	64
-	1	5-18022-5	SCR, HEX HD CAP, M4 X 6.0	59
-	3	2168400-4	SHCS, LOW HEAD, RoHS, M4 X 8	57
-	2	2168083-8	SCR, SKT HD CAP, RoHS, M4 X 16	56
-	2	5018030-1	NUT, HEX, REG, RoHS, M3	54
-	2	986965-8	NUT, LOCK, HEX, TORQUE (M4)	53
-	1	1-5018030-0	NUT, HEX, REG, RoHS, M3.5	52
-	1	2063961-1	FEED FINGER	51
-	1	18023-9	SCR, SKT HD CAP M4 X 6.0	49
-	1	1803602-1	SCR, BHSC, RoHS (M8 X 25)	41
-	7	1-18028-2	WASHER, FLAT, REG M4	33
-	2	2168083-8	SCR, SKT HD CAP, RoHS, M4 X 16	31
-	2	2168083-2	SCR, SKT HD CAP, RoHS, M4 X 8.0	29
-	1	690455-1	STRIPPER, FRONT CASTING	27
-	2	1-2168083-5	SCR, SKT HD CAP, RoHS, M4 X 30	25
-	1	2-1752371-0	PLATE, STRIP GUIDE	24
-	1	240825-5	PLATE, STRIP HOLD DOWN	23
-	2	2-22281-3	SPRING, COMPRESSION	22
-	1	1803292-1	DRAG	20
-	2	1901259-6	GUIDE, LOWER STRIP	18
-	1	240644-1	PLATE, REAR SHEAR	11
-	2	7-240645-4	SPACER, SHEAR PLATE	10
-	1	240642-1	PLATE, FRONT SHEAR	9
1	1	2-1803257-0	ANVIL, COMBINATION, END FEED	8
-	1	1803366-3	BLADE, SLUG	7
-	-	-	-	6
-	1	8-240641-5	SPACER	5
-	1	238011-2	BLOCK, CRIMPER SPACER	4
1	1	9-2119582-2	CRIMPER, INSULATION F PREMIUM	3
-	1	455888-5	SPACER, CRIMPER	2
1	1	409414-4	CRIMPER, WIRE	1
-	77-22	PART NO	DESCRIPTION	ITEM NO

DIMENSIONS:		TOLERANCES UNLESS OTHERWISE SPECIFIED:		MATERIAL:		FINISH:	
mm	0 PLC ±	1 PLC ±	2 PLC ±	3 PLC ±	4 PLC ±	ANGLES	FINISH
Customer Accessible Production Drawing				SCALE	1:1	SHEET	3 OF 4



TE Connectivity
Harrisburg, PA 17105-3608

NAME: Ocean End Feed Applicator

SIZE: 00779 C=2150696

LOC		DIST		REVISIONS			
A	66	P	LTM	DESCRIPTION	DATE	DWN	APVD
		-	-	SEE SHEET 1	-	-	-

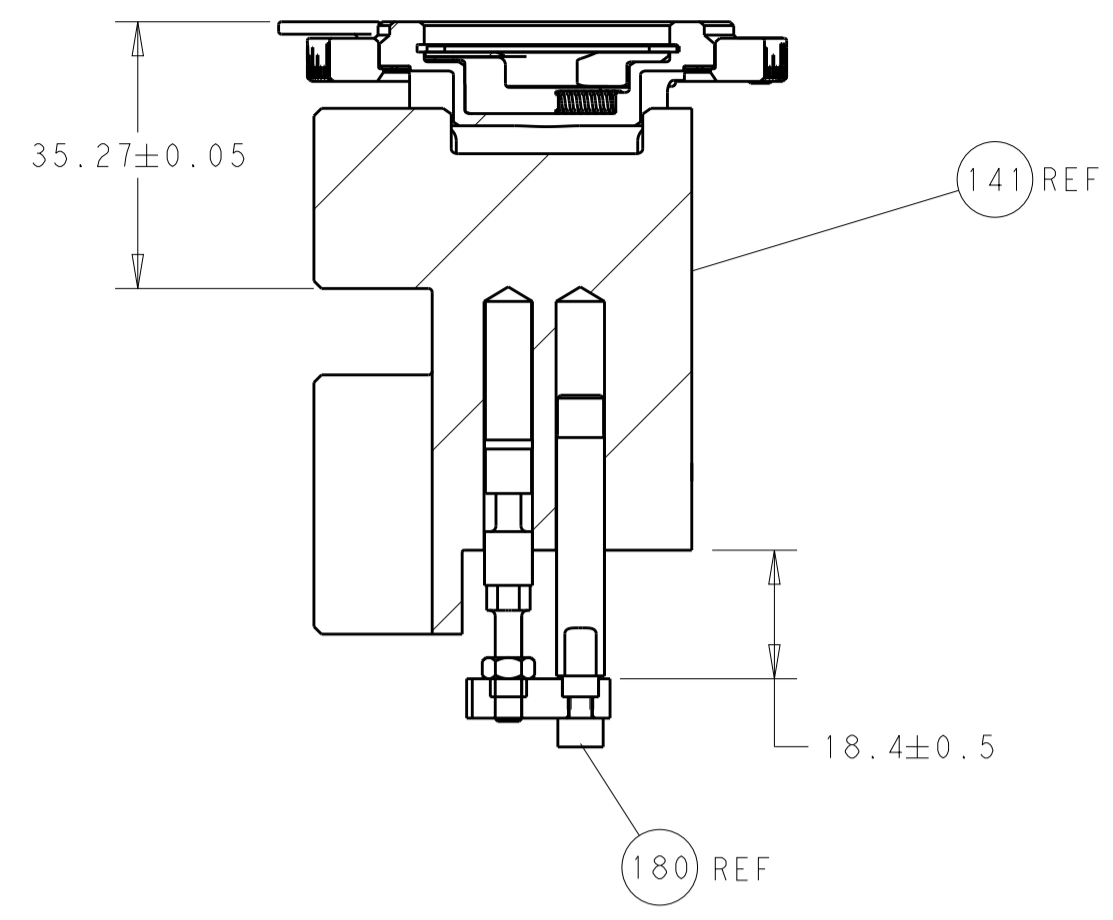

RAM AND HOLDDOWN SET-UP

FEED TYPE

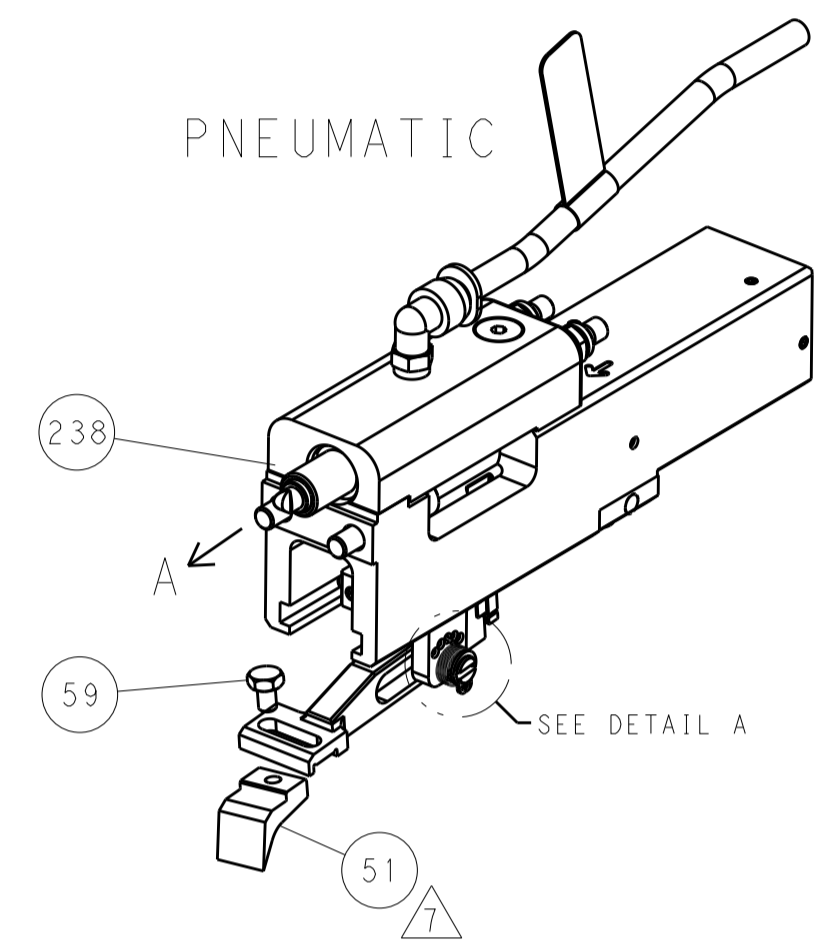

FEED SPRING SETTING POSITION

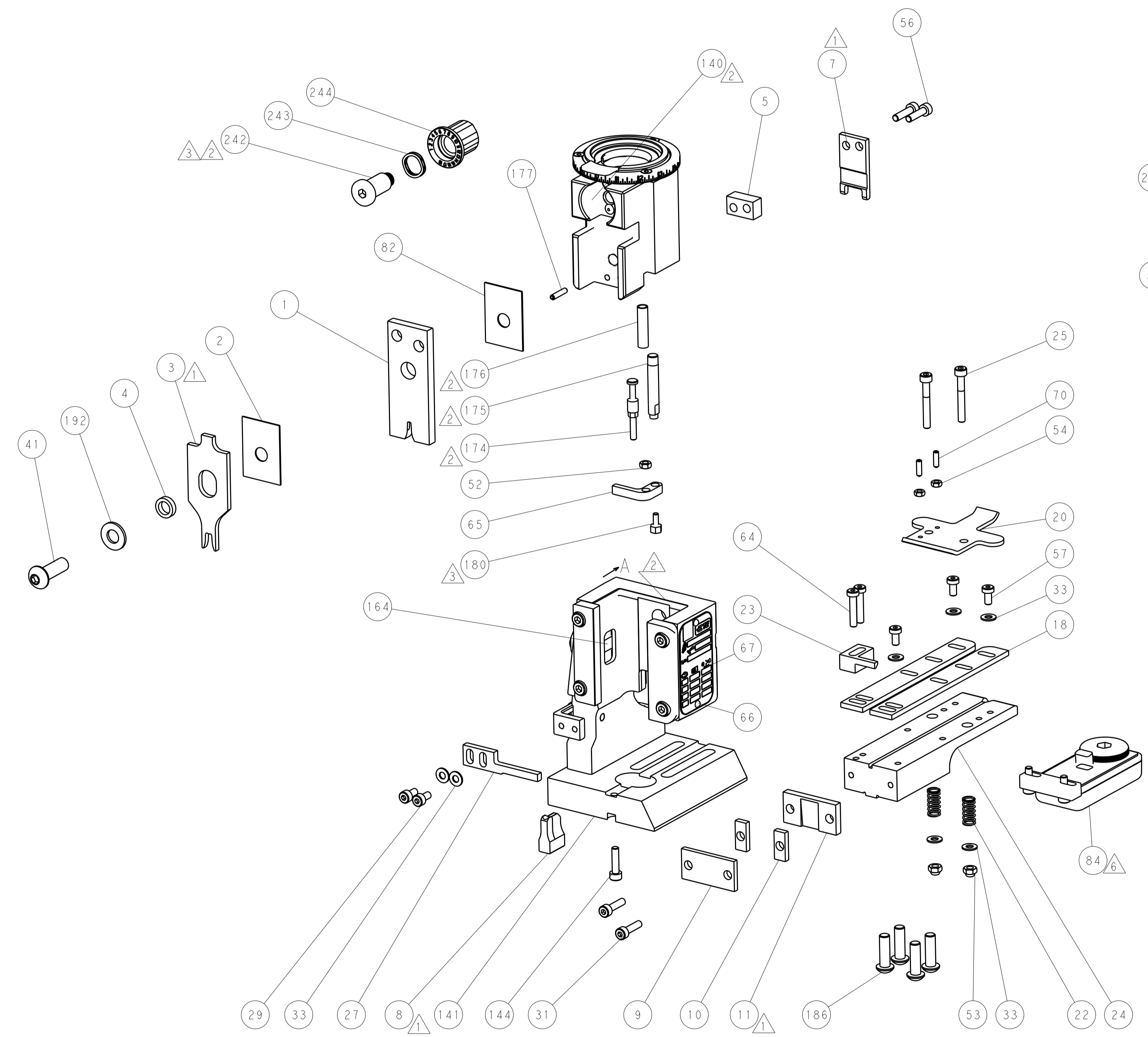
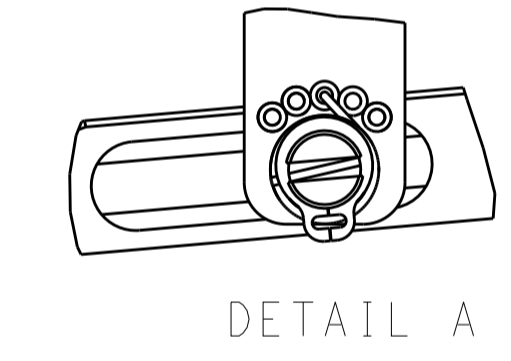

CAM POSITION

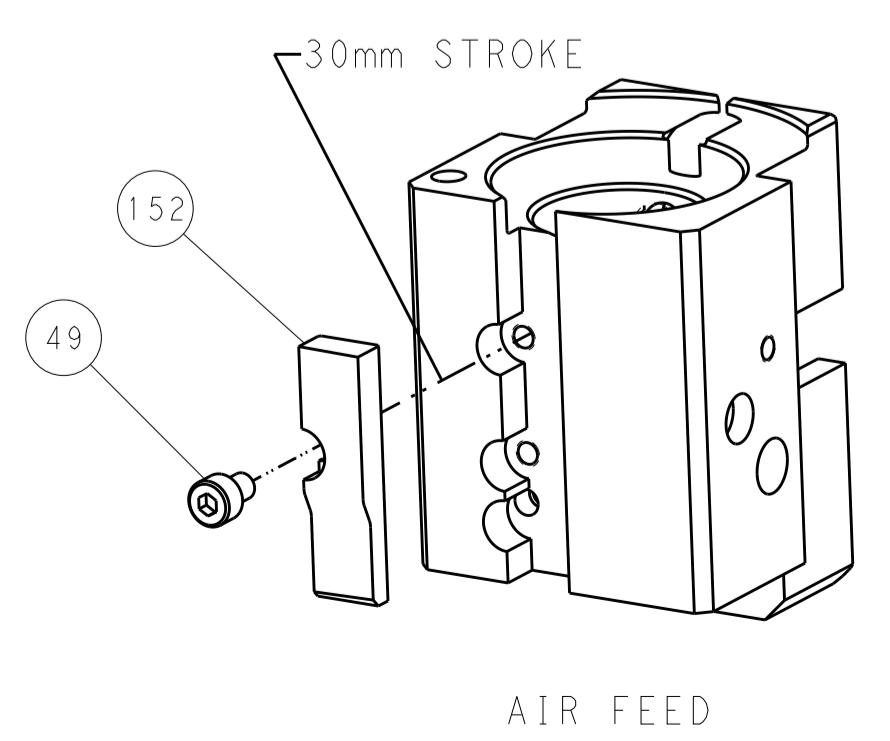

AIR FEED

PACIFIC VERSION
 Shown on sheets 3 of 4 & 4 of 4
 (Atlantic version shown on sheets 1 of 4 & 2 of 4)

DIMENSIONS:		TOLERANCES UNLESS OTHERWISE SPECIFIED:		DWN: J. HOU 14JUL2016		CHK: L. ZHANG 14JUL2016		APVD: L. ZHANG 14JUL2016		NAME: J. HOU		TE Connectivity Harrisburg, PA 17105-3608	
mm	0 PLC ±	1 PLC ±	2 PLC ±	3 PLC ±	4 PLC ±	ANGLES ±	FINISH ±	PRODUCT SPEC	APPLICATION SPEC	SIZE	CAGE CODE	DRAWING NO	RESTRICTED TO
										A11	00779	©=2150696	
Customer Accessible Production Drawing										SCALE	1:1	SHEET	4 OF 4
										REV	E		

单击下面可查看定价，库存，交付和生命周期等信息

[>>TE Connectivity\(泰科\)](#)