



CODE 21 - LOW PROFILE HEAT SHRINK BOOT BACKSHELL

203M612-19B

SERIES _____
 ORDER NUMBER (TABLE 1) _____
 MATERIAL _____
 REFER TO CH00-0250-004
 FINISH _____
 REFER TO CH00-0250-004

NOTES:

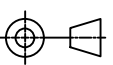
1. THIS PRODUCT IS DESIGNED TO TERMINATE A HEAT SHRINKABLE LIPPED BOOT TO A CONNECTOR.
2. FOR ADDITIONAL DIMENSIONS, ORDERING INFORMATION AND MODIFICATIONS, SEE CH00-0250-004.
3. BACKSHELL TO BE PERMANENTLY MARKED/BAGGED AND LABELLED WITH CODE IDENTIFICATION NUMBER AND PART NUMBER. (e.g. 06090-203M612-19B).
4. KNURL INSIDE BOOT GROOVE MAY BE SUPPLIED AT MANUFACTURER'S OPTION.
5. BACKSHELL MATES TO MIL-C-26482 SERIES I, CLASS E, F, MS3110, MS3111, MS3116 CONNECTORS.

DRAWN	W.RUST	DATE 14/09/2015	 3RD ANGLE PROJECTION NOT TO SCALE	TITLE: LOW PROFILE HEAT SHRINK BOOT BACKSHELL	 Polamco 		
CHECKED		14/09/2015				ASSY USED ON: MIL-DTL-26482 SERIES I	
APPROVED	K.SHEPPARD	09/10/2015	UNLESS OTHERWISE SPECIFIED ALL DIMENSIONS IN MILLIMETRES GENERAL TOL LINEAR +/-0,25MM ANGULAR +/- 1°	TE CONNECTIVITY - POLAMCO LTD RESERVES THE RIGHT TO AMEND THIS DRAWING AND THE INFORMATION SET FORTH HEREON AT ANY TIME. USERS SHOULD DATE THE SUITABILITY OF THE PRODUCT FOR THEIR APPLICATION.	DRAWING NO: 203M6XX		DRAWING REV: H
APPROVED	H.SMITH	14/10/2015					
REVISIONS							
LTR	DESCRIPTION	DATE	APPROVED				
G	REVISED PER ECO-15-002747	19/02/15	H.SMITH				
H	REVISED PER ECO-15-013980	14/10/2015	H.SMITH				
TE CAGE CODE: 06090 POLAMCO/TE CAGE CODE: U5792							

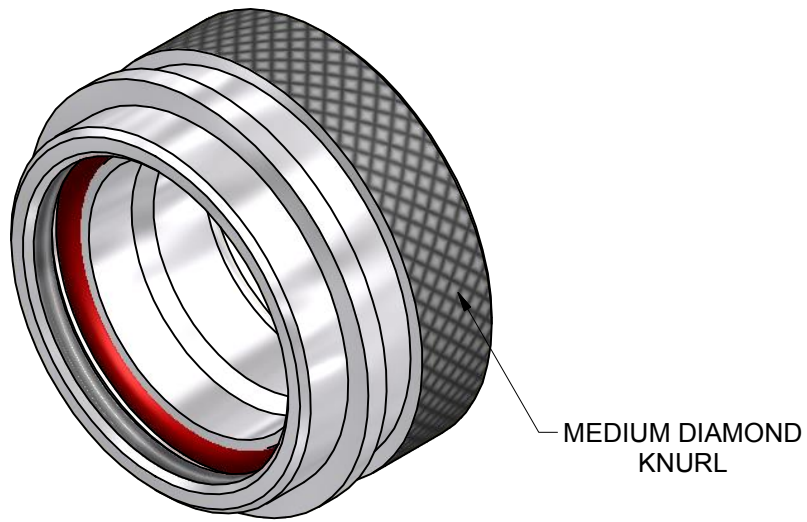

A-A

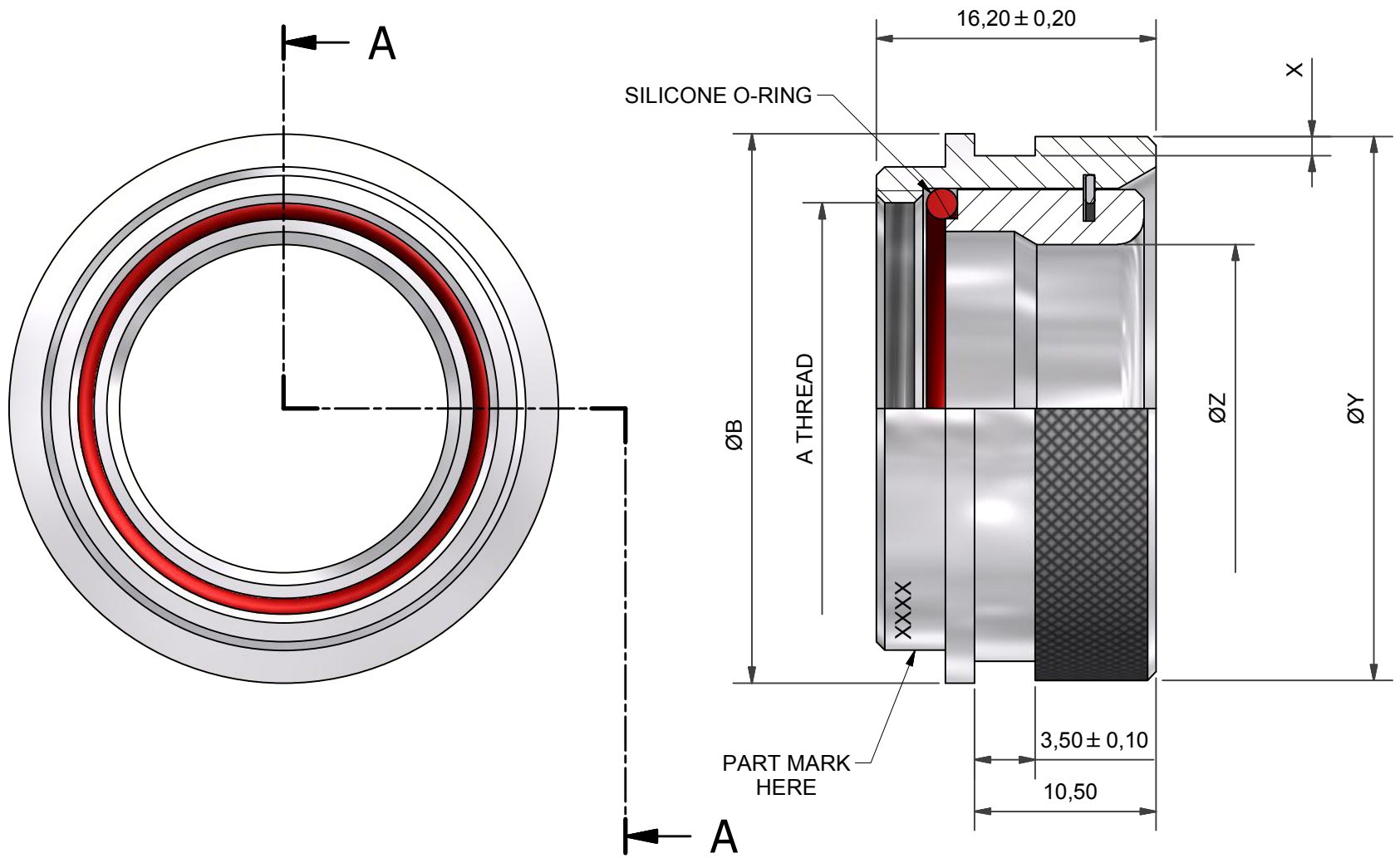

TABLE 1

PART NUMBER	SHELL SIZE (5)	A THREAD	ØB MAX	X +0,2/-0	ØY +0,00/-0,40	ØZ MIN
203M608	8	7/16-28UNEF	19,1	1,1	17,5	7,0
203M610	10	9/16-24UNEF	22,3	1,1	20,7	9,7
203M612	12	11/16-24UNEF	25,4	1,1	23,9	13,4
203M614	14	13/16-20UNEF	28,6	1,1	27,0	15,8
203M616	16	15/16-20UNEF	31,8	1,1	31,5	18,9
203M618	18	1 1/16-18UNEF	35,0	1,1	33,5	21,3
203M620	20	1 3/16-18UNEF	38,1	1,7	36,5	24,5
203M622	22	1 5/16-18UNEF	41,3	1,7	39,8	27,7
203M624	24	1 7/16-18UNEF	44,5	1,7	43,0	30,9

DRAWN	W.RUST	DATE	<p>3RD ANGLE PROJECTION NOT TO SCALE</p>
CHECKED		14/09/2015	
APPROVED	K.SHEPPARD	09/10/2015	
APPROVED	H.SMITH	14/10/2015	

TITLE:
LOW PROFILE HEAT SHRINK BOOT BACKSHELL

ASSY USED ON:
MIL-DTL-26482 SERIES I



LTR	DESCRIPTION	DATE	APPROVED
G	REVISED PER ECO-15-002747	19/02/15	H.SMITH
H	REVISED PER ECO-15-013980	14/10/2015	H.SMITH

TE CAGE CODE: 06090
POLAMCO/TE CAGE CODE: U5792

TE CONNECTIVITY - POLAMCO LTD RESERVES THE RIGHT TO AMEND THIS DRAWING AND THE INFORMATION SET FORTH HEREON AT ANY TIME. USERS SHOULD JUDGE THE SUITABILITY OF THE PRODUCT FOR THEIR APPLICATION.

DRAWING NO:
203M6XX

DRAWING REV:
H

SHT
2

单击下面可查看定价，库存，交付和生命周期等信息

[>>TE Connectivity\(泰科\)](#)