

11 MOUNTED COVER OPTIONS
Befestigungsmoeglichkeiten der Kapfen

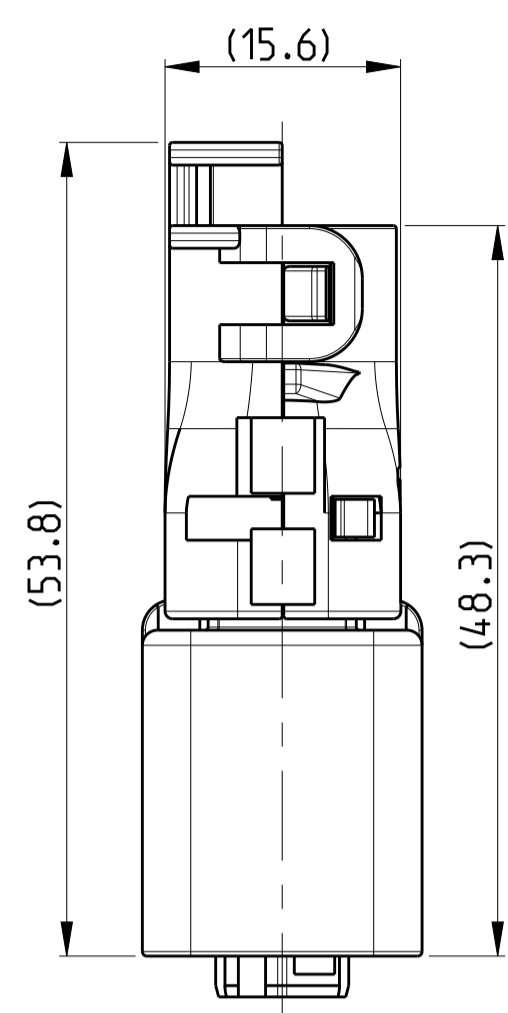

REVISIONS				
P	LTR	DESCRIPTION	DATE	DWN APVD
H		DETAILS SEE PCN E-12-019940	16NOV2012	CG JG
H1		DETAILS SEE PCN E-16-011236	15AUG2016	MAH. GILC
H2		DETAILS SEE PCN E-18-019571	03JAN2019	MAH. GILC
H3		DETAILS SEE PCN E-19-010178	28JUN2019	FRAN GILC

- NOTES
Bemerkungen
- 1 TE LOGO
TE Logo
 - 2 TE ORDER-NO.
TE Bestell-Nr.
 - 3 PRODUCTION DATE
Produktionsdatum
 - 4 LETTER-INSERT FOR THE REVISION STATUS OF THE MOULD
Schriftsatz fuer Aenderungszustand des Werkzeuges
ACTUAL STATUS: SEE TABLE
Aktueller Stand: siehe Tabelle
 - 5 MATERIAL MARKING ACCORDING TO VDA 260
Werkstoffkennzeichnung nach VDA 260
 - 6 BULK PACKAGING IN CORRUGATED BOX
Schuettgut im Versandkarton
 - 7 CABLE EXIT DESIGNED FOR CORRUGATED TUBE NW 8.5
Kabelabgang ausgelegt fuer Wellrohr NW 8.5
 - 8 MALFUNCTION CAUSED BY LAQUER IS NOT COVERED
BY TE WARRANTY
Funktionsbeeintraechtigung durch Lackieren liegt nicht
im Einfluss und Gewaehrleistungsumfang von TE
 - 9 WARPAGE UP TO -1.0mm FROM NOM. DIMENSION PERMITTED
Verzug zulaessig bis -1.0mm vom Nennmass
 - 10 MAX. CABLE TIE WIDTH: 3.8mm
max. Kabelbinderbreite: 3.8mm
 - 11 SUITABLE FOR TAB AND RECEPTACLE HOUSING GROUP A
SEE PRODUCT GROUP DRAWING 1563709
Passend fuer Flachstecker- und Buchsengehause der Gruppe A
siehe Produktgruppenzeichnung 1563709
 - 12 CABLE EXIT DESIGNED FOR CORRUGATED TUBE NW 4.5
SCHLEMMER ORDER NO. 1200068
Kabelabgang ausgelegt fuer Wellrohr NW 4.5
Schlemmer Bestell-Nr. 1200068

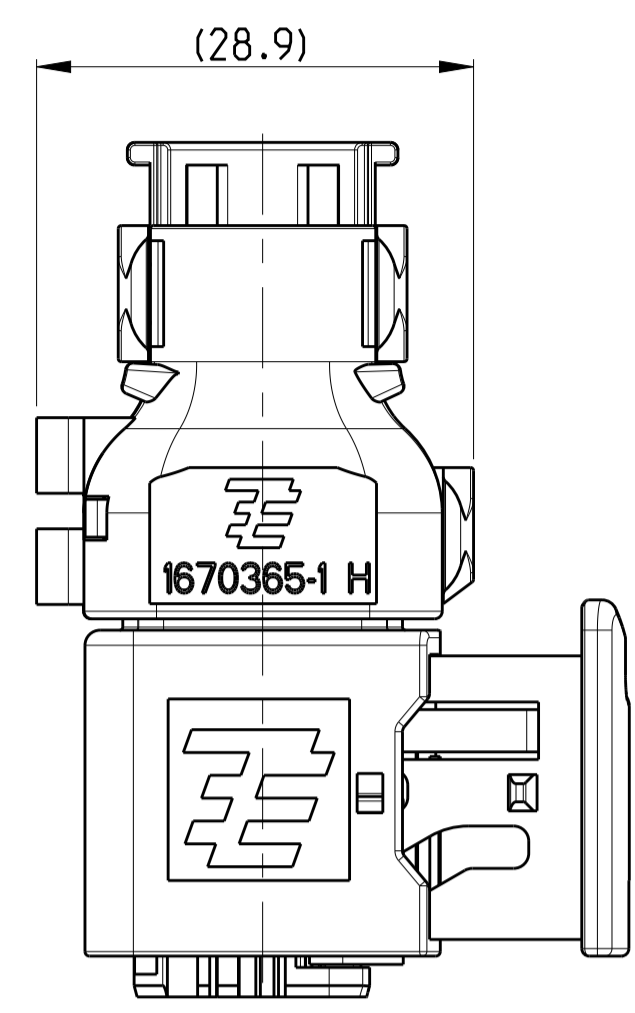
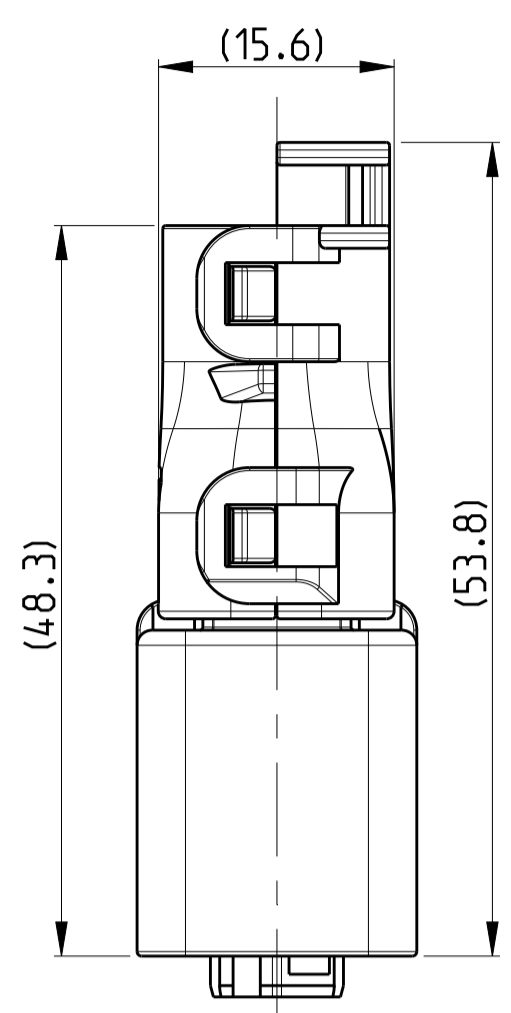
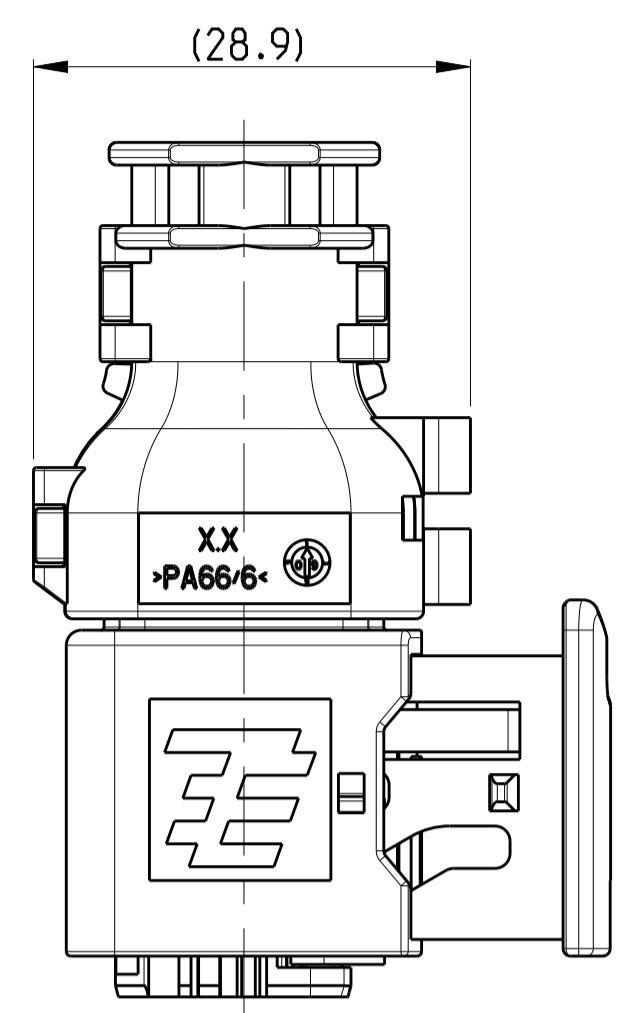
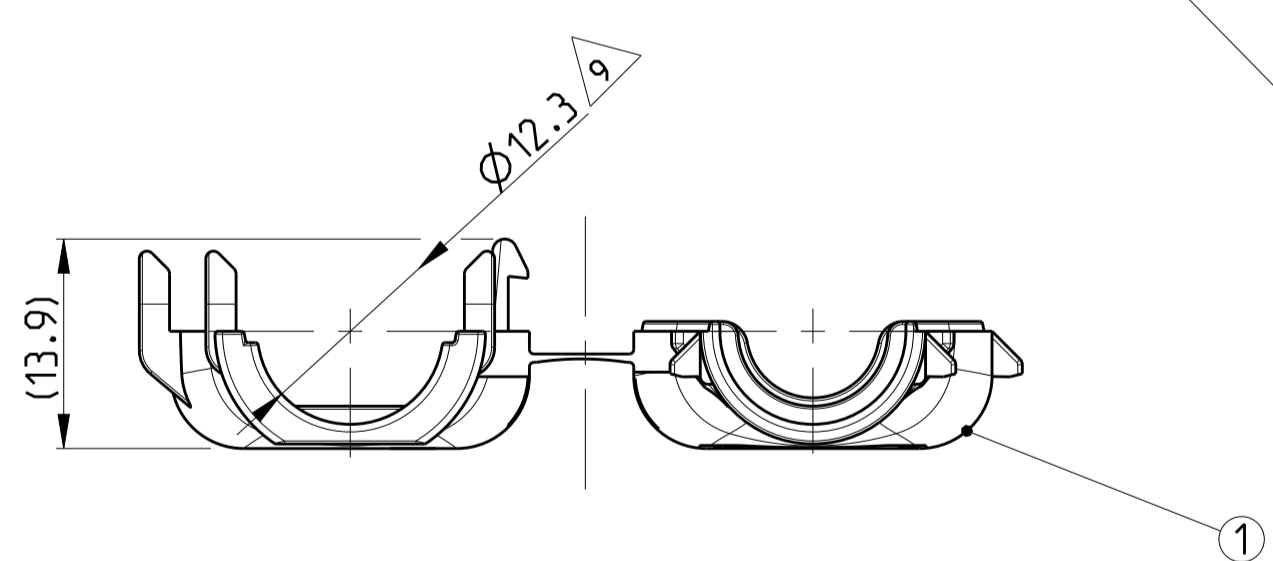
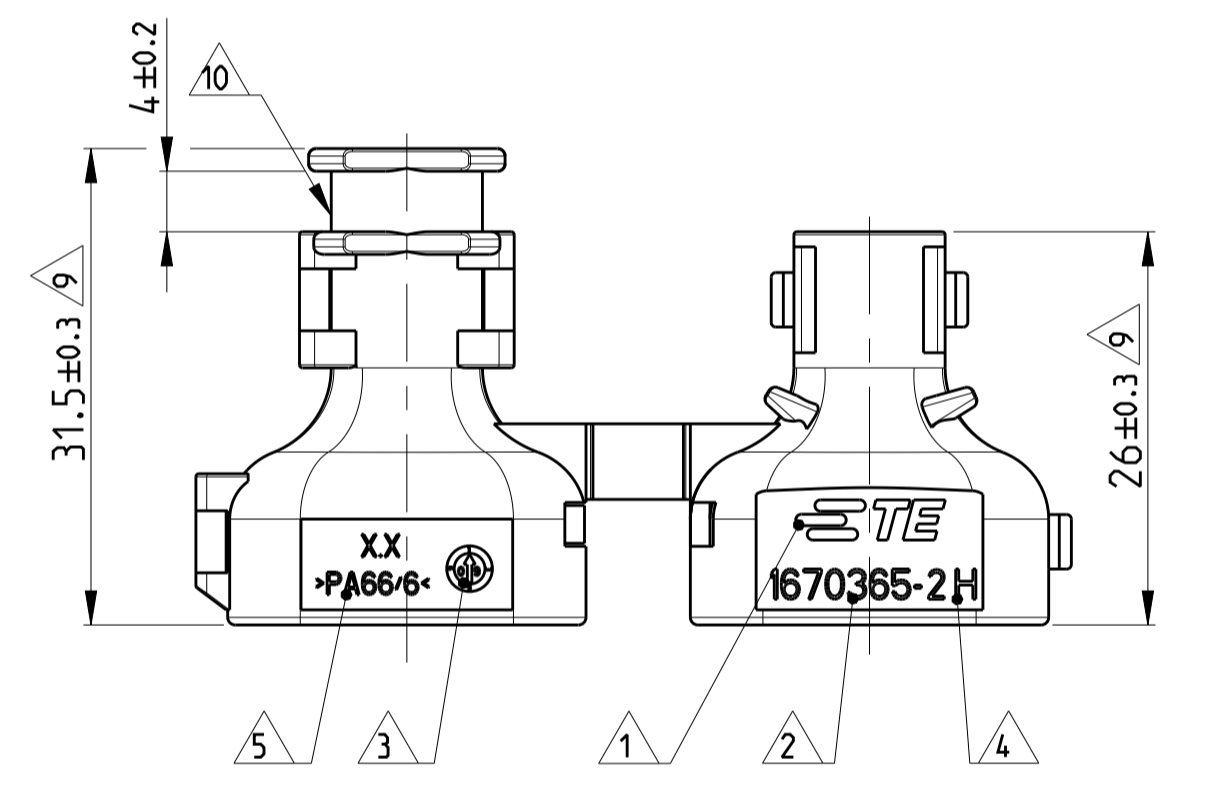
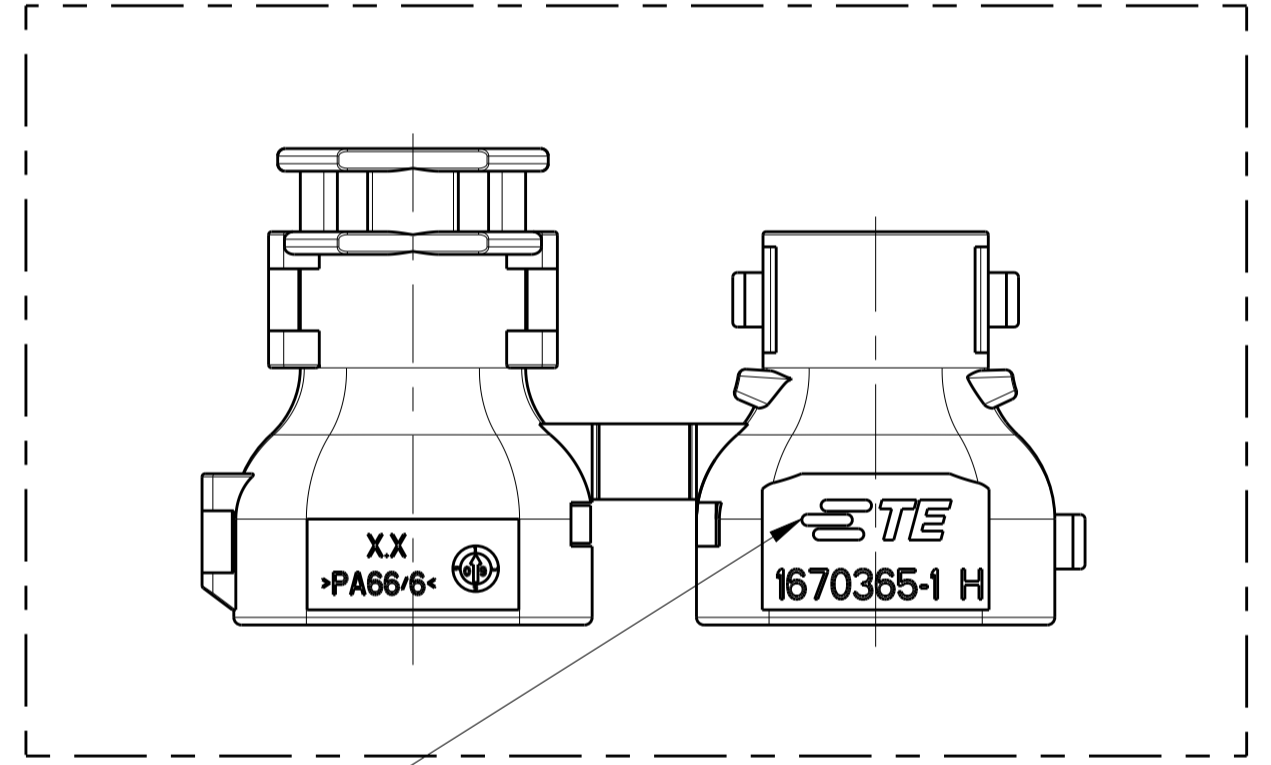
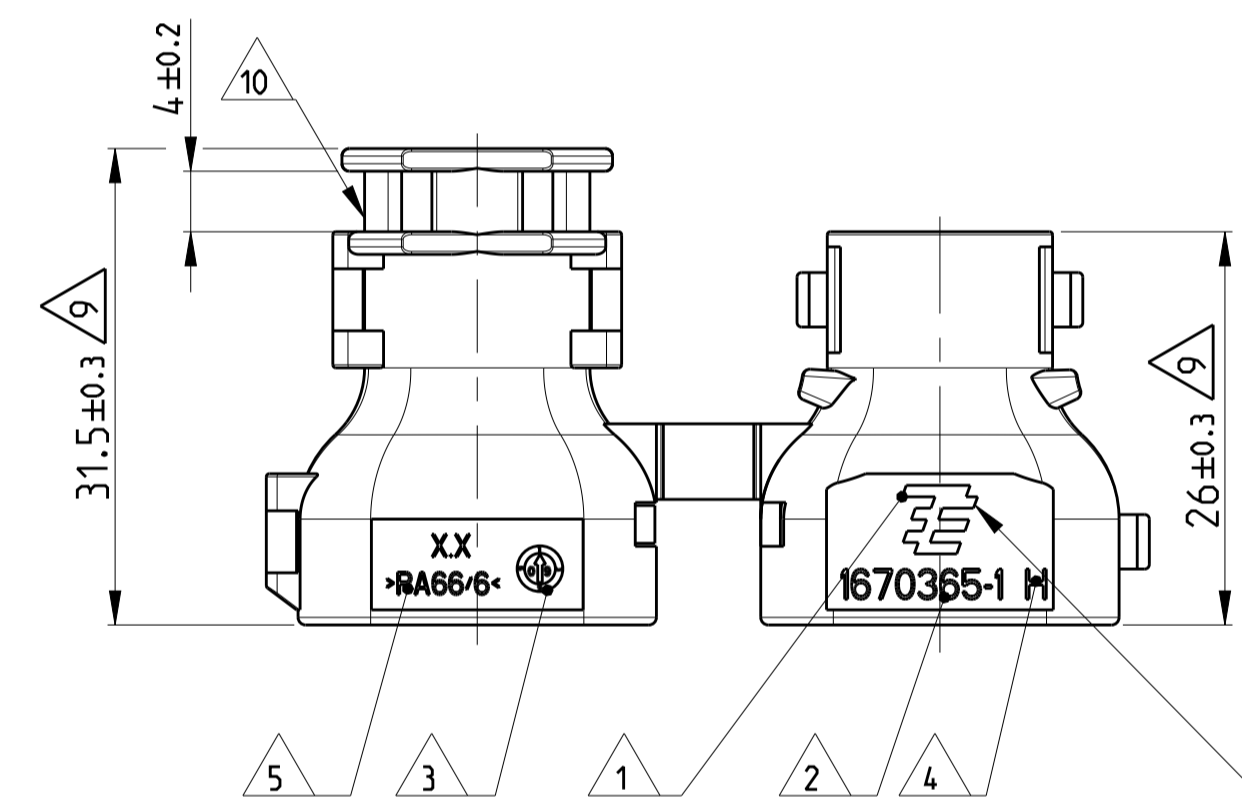

TE LOGO RELATED TO MOLDING TOOL
TE Logo abhaengig von Spritzgusswerkzeug

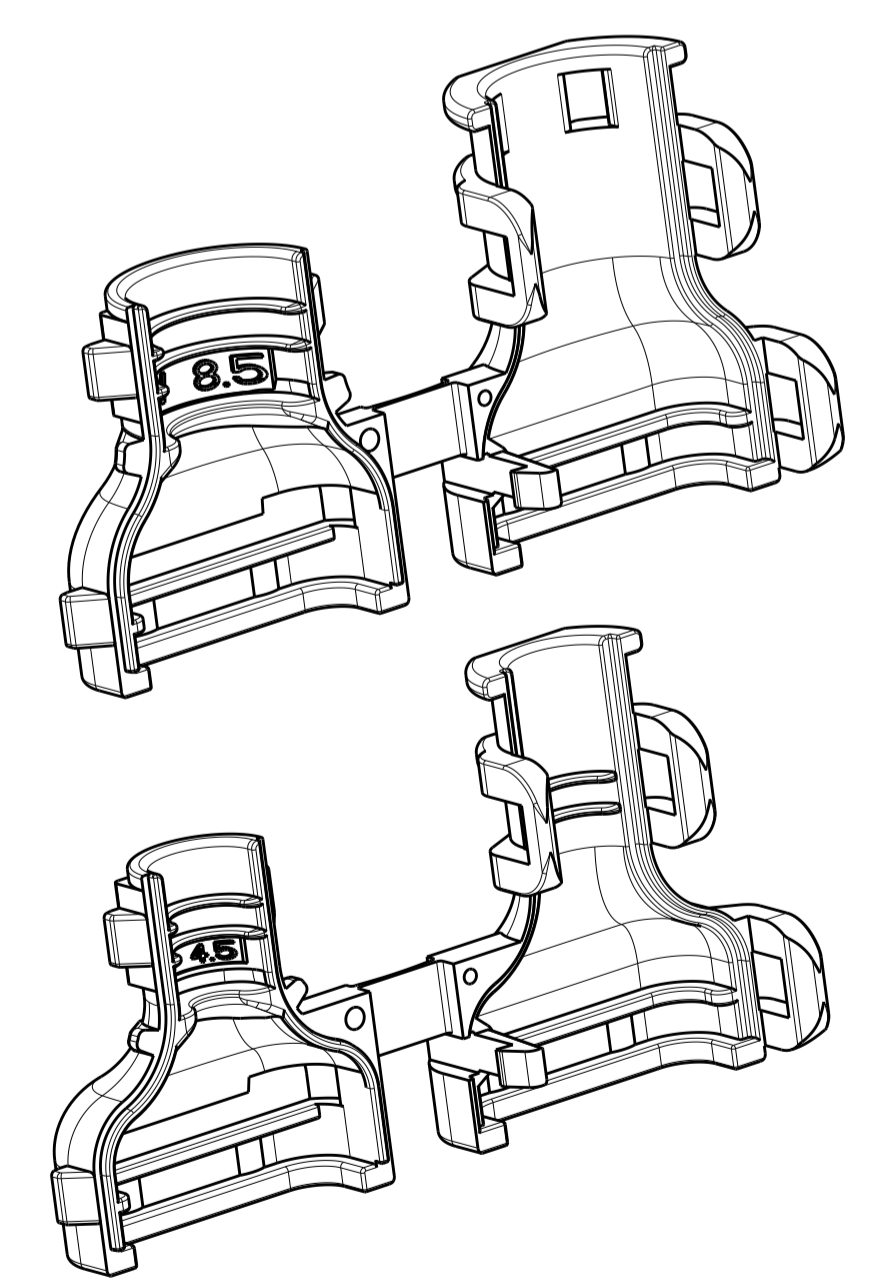
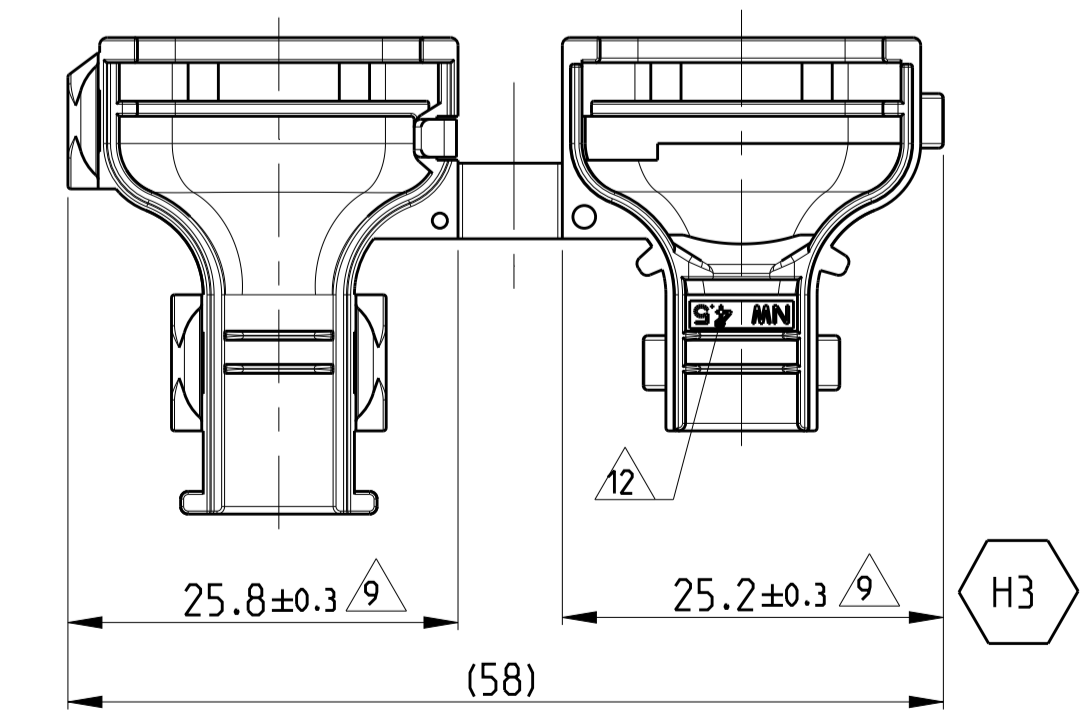
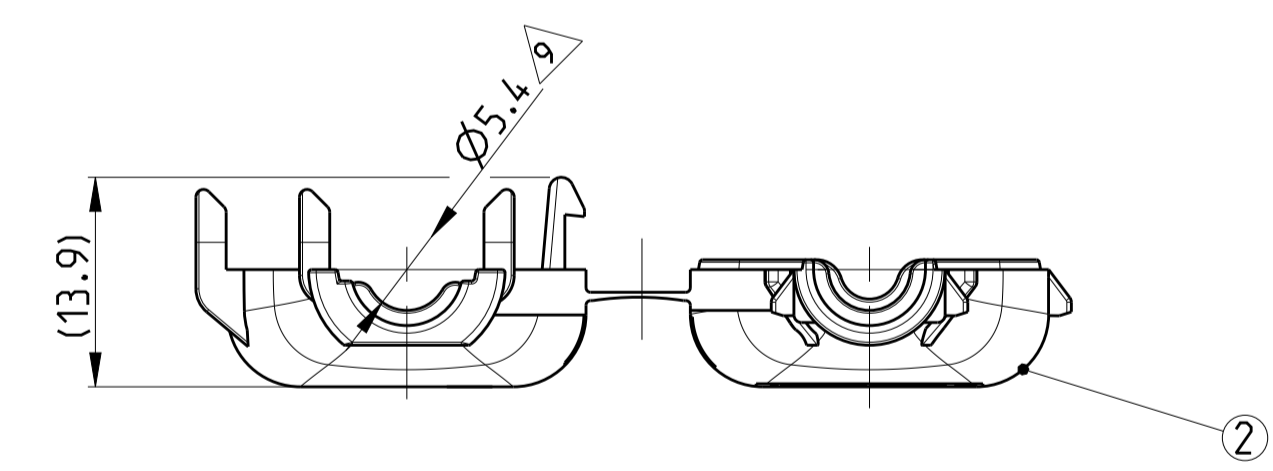
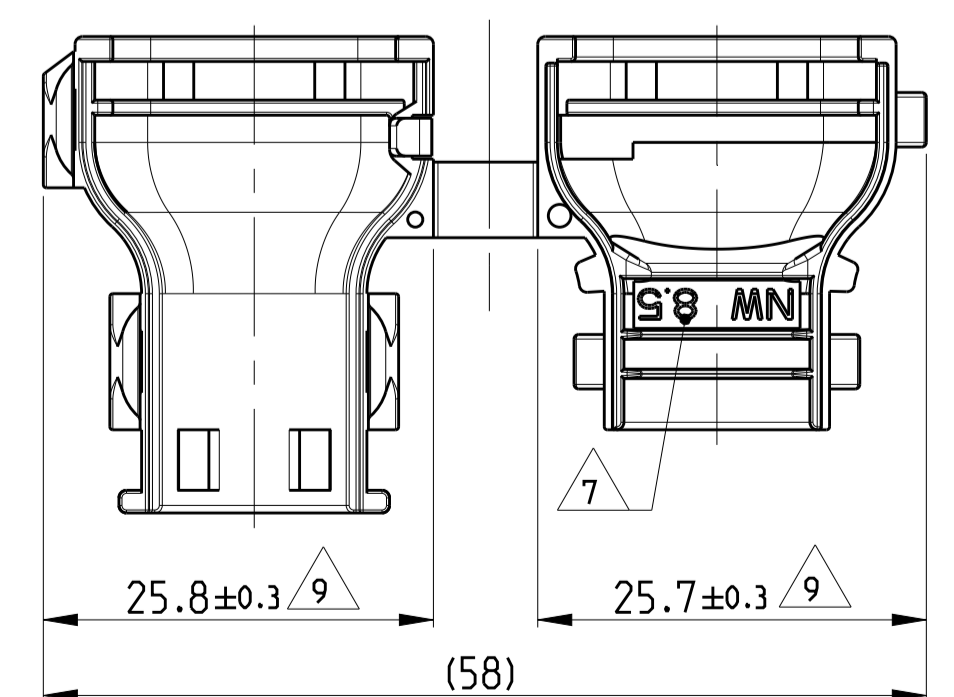

ITEM	REV.	DESCRIPTION Beschreibung	ITEM
0-1670365-2	H	COVER, 180 * Kappe, 180 *	2
0-1670365-1	H	COVER, 180 * Kappe, 180 *	1
TE ORDER-NO. TE Bestell-Nr.	REV.	DESCRIPTION Beschreibung	ITEM

TOLERANCES UNLESS OTHERWISE SPECIFIED ACC. TO DIN 16001-140 CENTRIC TO NOMINAL DIMENSION, EDITION 1992-11 SHALL APPLY. Freimassstabungen nach DIN 16001-140. Es gilt die Ausgabe 1992-11.	
DIESE ZEICHNUNG IST EIN KONTROLLIERTES DOKUMENT. BEMASSUNGEN UND TOLERANZEN GEMAESS GPS (ISO STANDARDS).	
THIS DRAWING IS A CONTROLLED DOCUMENT. DIMENSIONING AND TOLERANCING PER GPS (ISO STANDARDS).	
DIMENSIONS: mm	TOLERANCES UNLESS OTHERWISE SPECIFIED: ISO 8015
MATERIAL PA66/6 (V-0)	FINISH BLACK schwarz
WEIGHT 3.1g	CUSTOMER DRAWING

D. Bischoff 260K12006 J. Grandzow 310K12006 C. Oberwein 02NOV2006		NAME COVER 180 Kappe 180 Grad HDSCS - GROUP A	
108-94.020 APPLICATION SPEC		RESTRICTED TO	
114-18756		SCALE 5:1 SHEET 1 OF 1 REV. H3	
A1 00779 C=1670365			

单击下面可查看定价，库存，交付和生命周期等信息

[>>TE Connectivity\(泰科\)](#)