

LOC	DIST	REVISIONS			
P	LTR	DESCRIPTION	DATE	DMN	APVD
D		REVISED PER ECO-08-014698	23JUN08	RG	AWF
D1		REVISED PER ECO-09-024927	10NOV09	KK	AEG

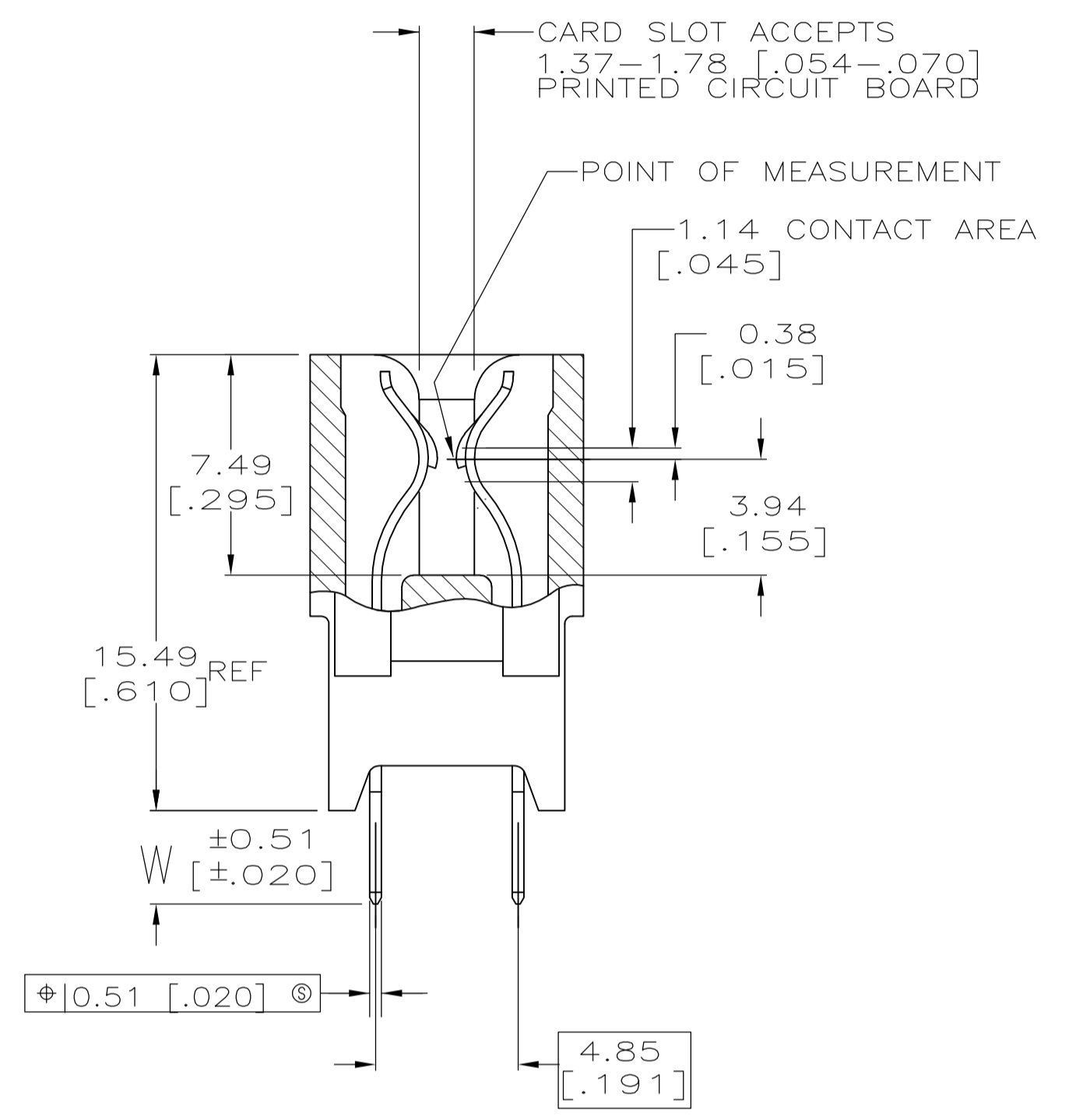
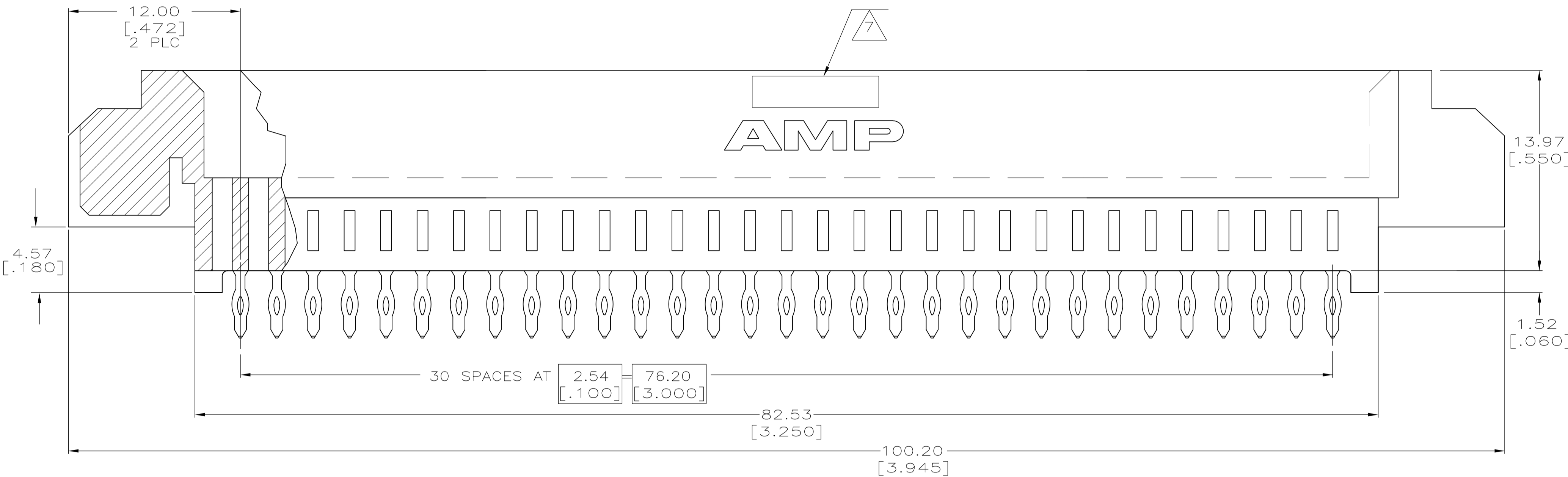
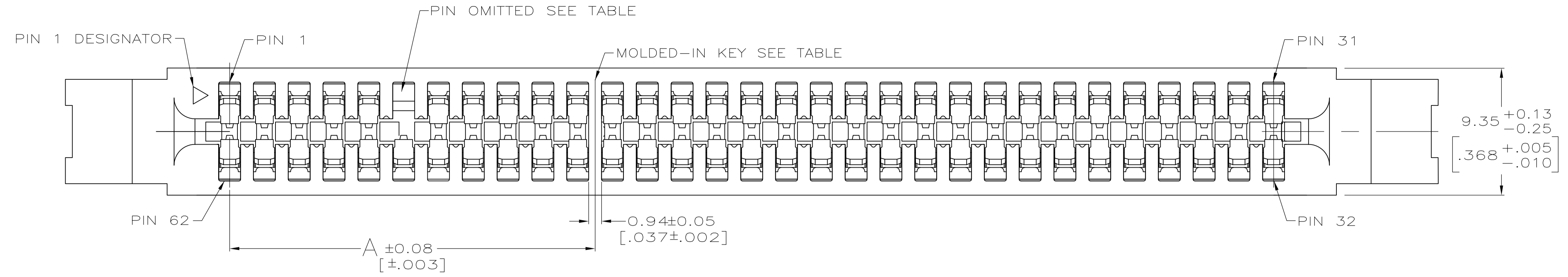

- 1 HOUSING: GLASS-FILLED POLYESTER, BLACK.
- 2 CONTACT: HIGH CONDUCTIVITY COPPER ALLOY.
- 3 NICKEL PLATE: 1.27µm[.000050] MIN - ALL OVER.
- 4 MATTE TIN PLATE: 2.54µm[.000100] MIN - SOLDER POSTS.
- 5 GOLD PLATE: 0.76µm[.000030] MIN - CONTACT AREA.
- 6 KEEP OUT ZONE APPLIES TO BOTH SIDES OF PC BOARD (FRONT AND BACK).
- 7 AMP PART NUMBER, DATE CODE AND CSA LOGO MARKED IN APPROXIMATE AREA SHOWN, EITHER SIDE.
- 8 DATUMS AND BASIC DIMENSIONS ESTABLISHED BY CUSTOMER.
- 9 4 OUNCE COPPER REQUIRED.
- 10 RETAINING CLIP: STAINLESS STEEL, NOT INCLUDED WITH CONNECTOR.

- 11. ELECTRICAL PERFORMANCE OF THIS CONNECTOR IS DIRECTLY RELATED TO THE VRM POWER MODULE BOARD DESIGN AND MAY BE AFFECTED BY CHANGES TO THAT DESIGN.
- 12. CONNECTOR PERFORMANCE IS BASED UPON INFORMATION FROM THE VRM 9.0 AND 9.1 MODULE BOARD DESIGN STANDARD.
- 13. CONNECTORS SHOWN ARE USED IN APPLICATIONS WITH VRM MODULES WEIGHING UP TO 6 OUNCES. ALTERNATIVE CONNECTOR AND LATCHING METHOD IS AVAILABLE FOR VRM MODULES WEIGHING 3 OUNCES AND LESS, CONSULT AMP ENGINEERING FOR ADDITIONAL INFORMATION.
- 14. ONE HOLE OMITTED FOR POLERIZATION, SEE TABLE FOR LOCATION.

RECOMMENDED FINISHED HOLE SIZES	TIN PLATED HOLE	GOLD PLATED HOLE
	φ 1.02 ± 0.08 [φ .040 ± .003]	φ 1.07 ± 0.05 [φ .042 ± .002]

16. OBSOLETE PARTS: OBSOLETE CIS STREAMLINING PER D.RENAUD/D.SINISI

13	OBSOLETE	4.75 [.187]	51.90 [2.043]	29.03 [1.140]	19	10	26.67 [1.050]	6	11,12	9.05,+12V	31	6489652-4	
13	OBSOLETE	3.18 [.125]	51.90 [2.043]	29.03 [1.140]	19	10	26.67 [1.050]	6	11,12	9.05,+12V	31	6489652-3	
13	16	OBSOLETE	3.18 [.125]	69.60 [2.740]	11.18 [.440]	26	3	8.89 [.350]	6	4,5	9.1,+48V	31	6489652-2
13			3.18 [.125]	49.28 [1.940]	31.50 [1.240]	18	11	29.21 [1.150]	6	12,13	9.1,+12V	31	6489652-1
		W	E	D	C	B	A	OMIT PIN AND HOLE	MOLDED KEY BETWEEN PINS	VRM DESIGNATION	NO OF DUAL POSN	PART NUMBER	

THIS DRAWING IS A CONTROLLED DOCUMENT.

AL FRANTUM 20 MAY 05  
 AL FRANTUM 20 MAY 05

**Tyco Electronics** Tyco Electronics Corporation  
 Harrisburg, Pa 17105-3608

PRODUCT SPEC  
 APPLICATION SPEC

CONNECTOR ASSEMBLY,  
 HIGH CURRENT CARD EDGE,  
 31 DUAL POSITION, 2.54 [0.100] CL

SIZE: A1 00779 C=6489652  
 WEIGHT: -

CUSTOMER DRAWING SCALE: 5:1 SHEET: 1 OF 3 REV: D1

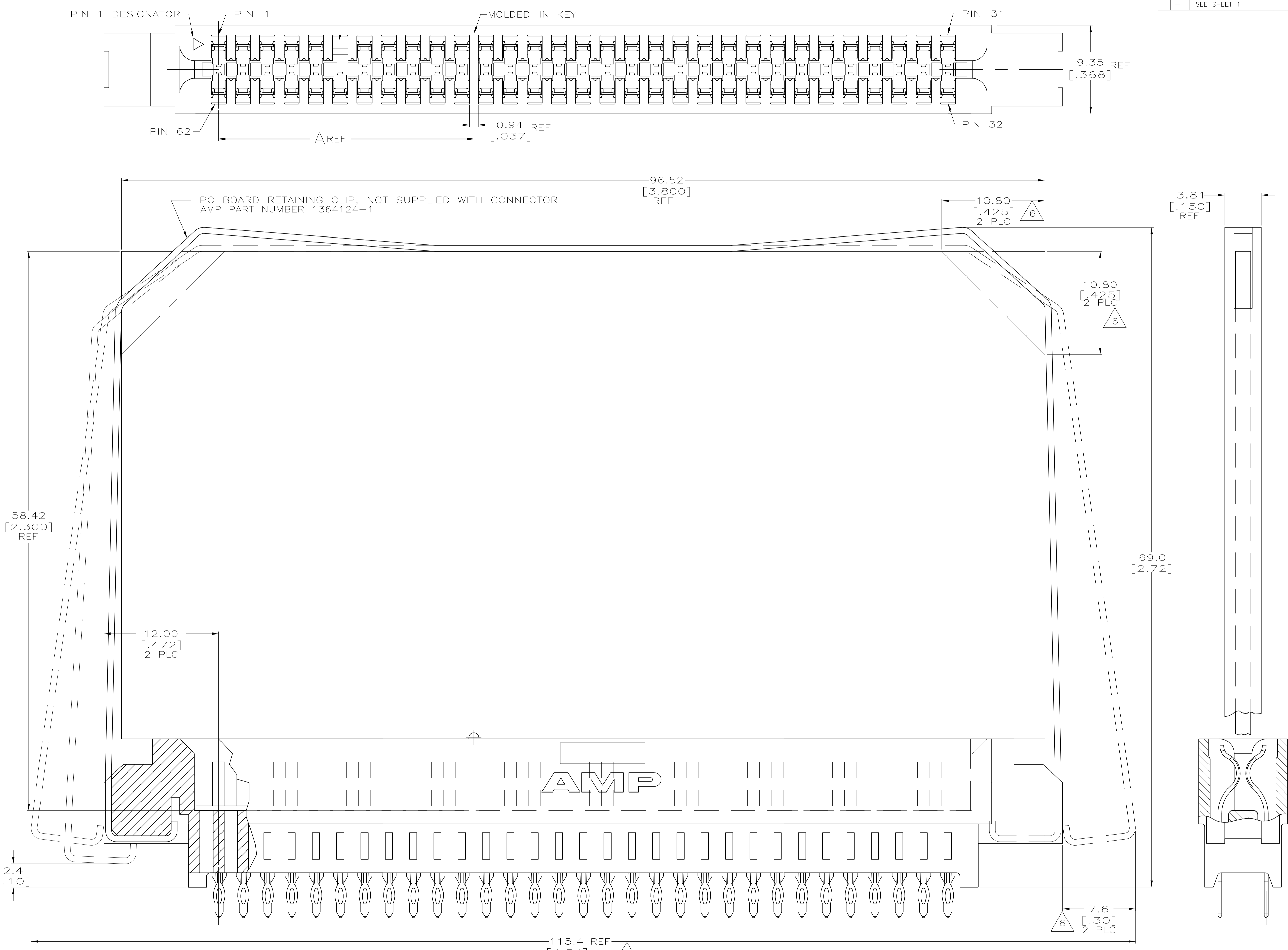

THIS DRAWING IS A CONTROLLED DOCUMENT.		DN AL FRANTUM 20 MAY 05	Tyco Electronics Corporation Harrisburg, Pa 17105-3608	
DIMENSIONS: mm [INCHES]		CHK AL FRANTUM 20 MAY 05	NAME	
TOLERANCES UNLESS OTHERWISE SPECIFIED:		APVD	PRODUCT SPEC	
0 PLC	± -		APPLICATION SPEC	
1 PLC	± -		SIZE	
2 PLC	± 0.25 [.01]		CAGE CODE	
3 PLC	± 0.13 [.005]		DRAWING NO	
4 PLC	± -		RESTRICTED TO	
ANGLES	± - °		WEIGHT	
MATERIAL	FINISH		A1 00779 C=6489652	
			CUSTOMER DRAWING	
			SCALE 5:1 SHEET 2 OF 3 REV D1	

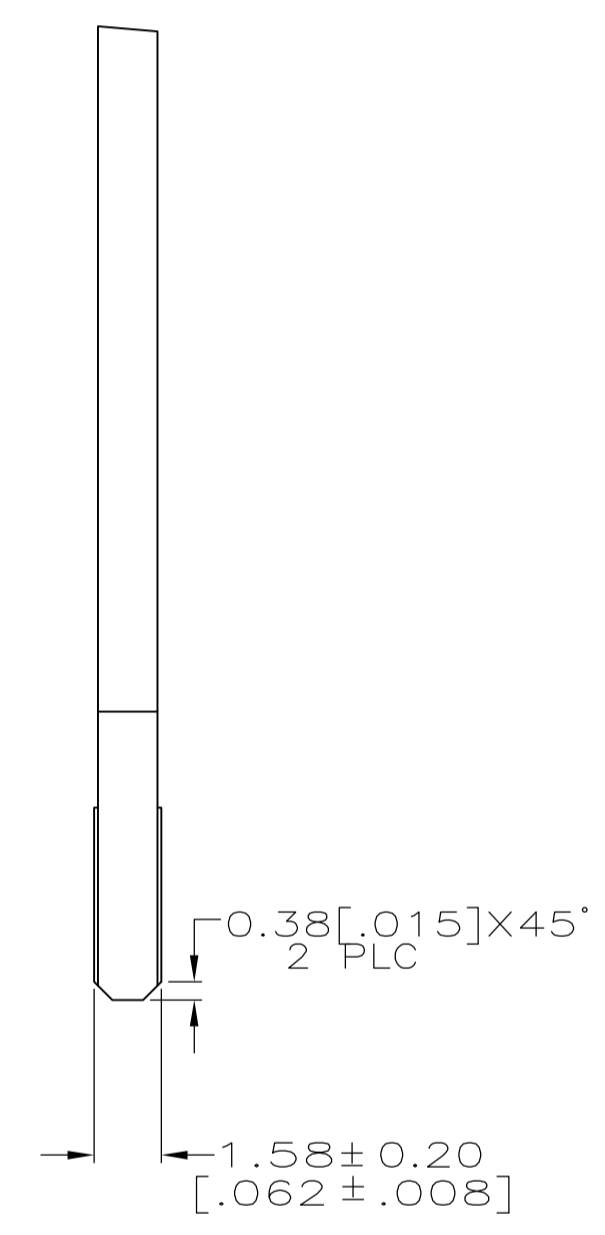
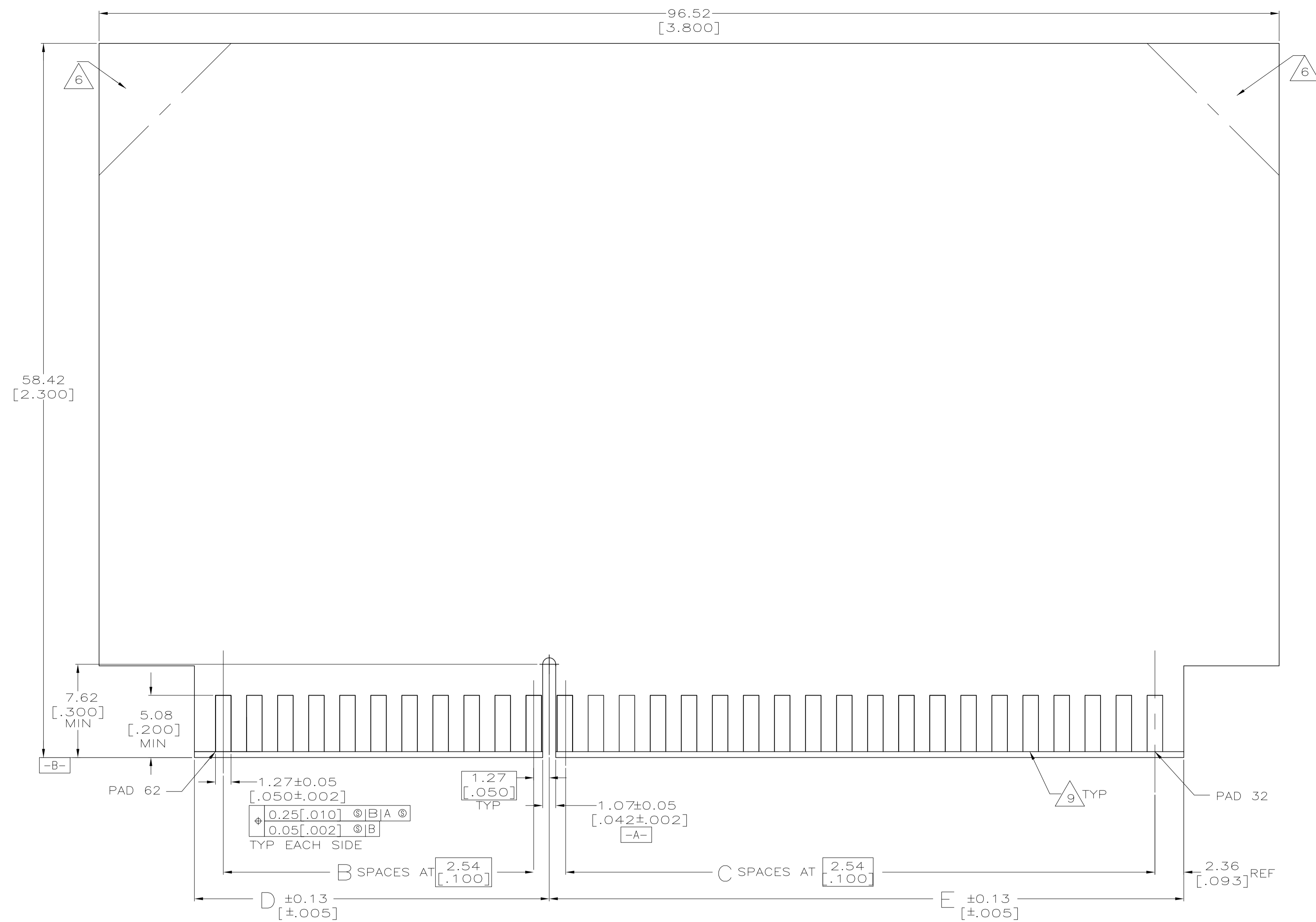

RECOMMENDED MATING BOARD EDGE CONFIGURATION

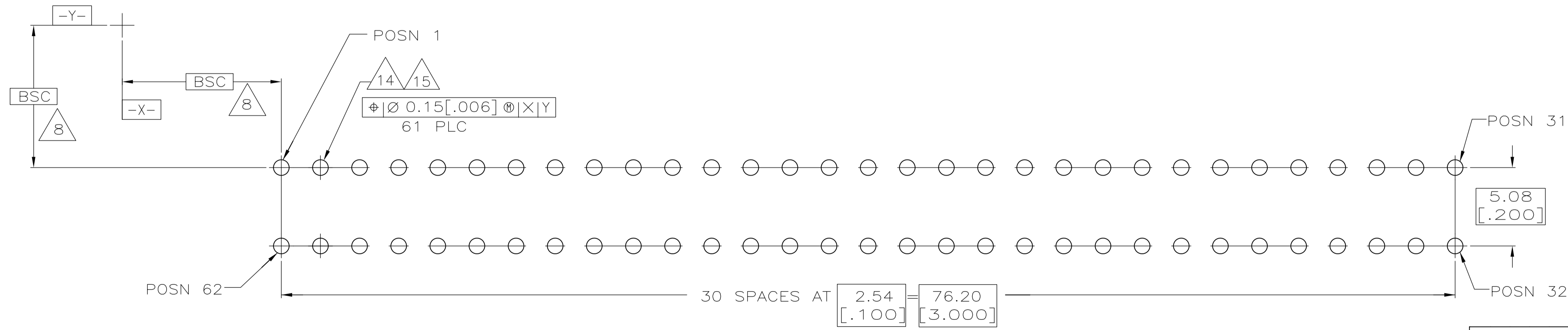

RECOMMENDED PC BOARD HOLE LAYOUT

THIS DRAWING IS A CONTROLLED DOCUMENT.		DIN AL FRANTUM 20 MAY 05	Tyco Electronics Corporation Harrisburg, Pa 17105-3608	
DIMENSIONS: mm [INCHES]		CIK AL FRANTUM 20 MAY 05	NAME	
TOLERANCES UNLESS OTHERWISE SPECIFIED:		APVD	PRODUCT SPEC	
0 PLC ± -	1 PLC ± -	APPLICATION SPEC		
2 PLC ± 0.25 [.01]	3 PLC ± 0.13 [.005]	SIZE CASE CODE DRAWING NO RESTRICTED TO		
4 PLC ± -	ANGLES ± -	WEIGHT	A1 00779 C=6489652	
MATERIAL	FINISH	CUSTOMER DRAWING		SCALE 5:1 SHEET 3 OF 3 REV D1

单击下面可查看定价，库存，交付和生命周期等信息

[>>TE Connectivity\(泰科\)](#)