

© 1962 BY AMP INCORPORATED. ALL RIGHTS RESERVED. AMP PRODUCTS COVERED BY PATENTS AND/OR PATENTS PENDING. APPROVED PER GOVT CONTRACT NO.

LOCATION FOR AMP-TAB FEMALE CONTACT

CAVITY IDENTIFICATION STAMPED ON TOP SURFACE OF ASSY - 1 PT NO ONLY

REVISIONS				
ZONE	LTR	DESCRIPTION	DATE	APPROVED
✓	T	REVISED PER 0600-3683-95	TA	10-95 J. WARNER
	U	REV PER CG3D-0250-01	CT	3-02 C.T.
	V	ECO-08-020973	PY	11-08 JW

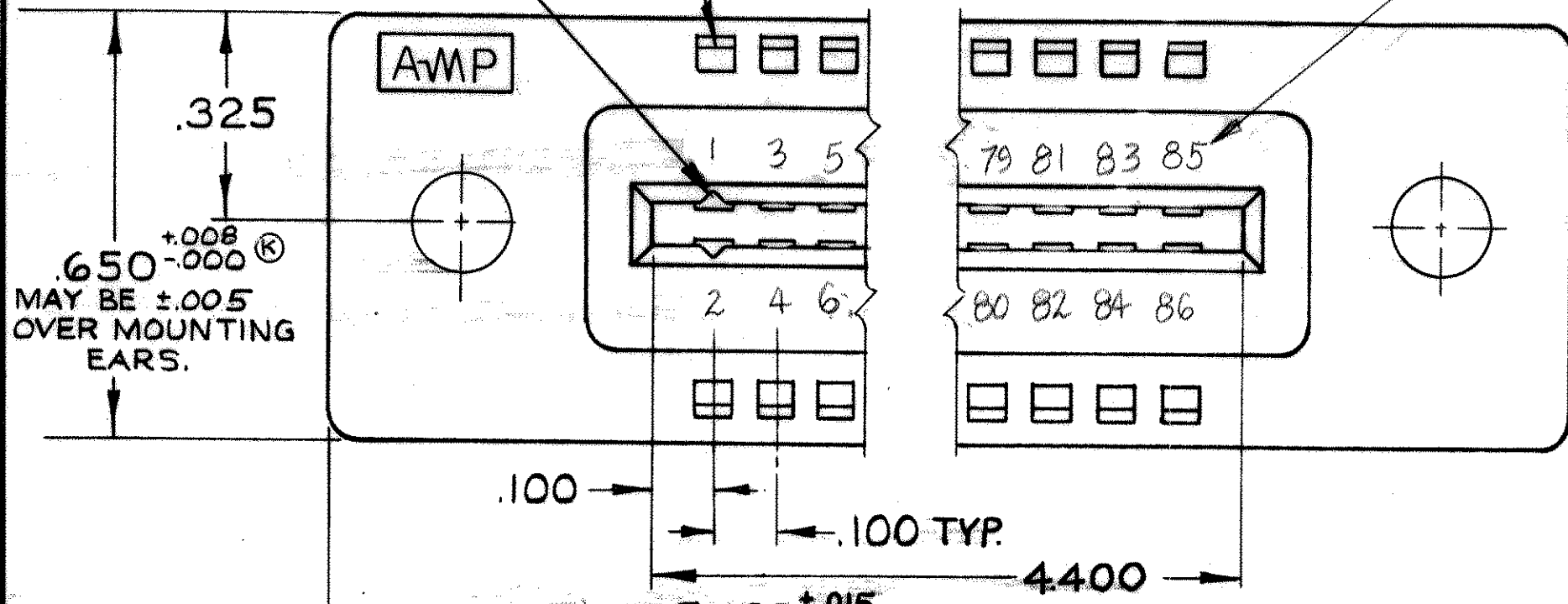

- 582593-1 1. AS SHOWN "J" DIA. HOLES = .128
- 085 582593-2 1. SAME AS -1 EXCEPT:
2. "J" DIA. HOLES = .156
- 3 1. SAME AS -1 EXCEPT:
2. CUSTOMER PART NO STAMPED ON SIDE.

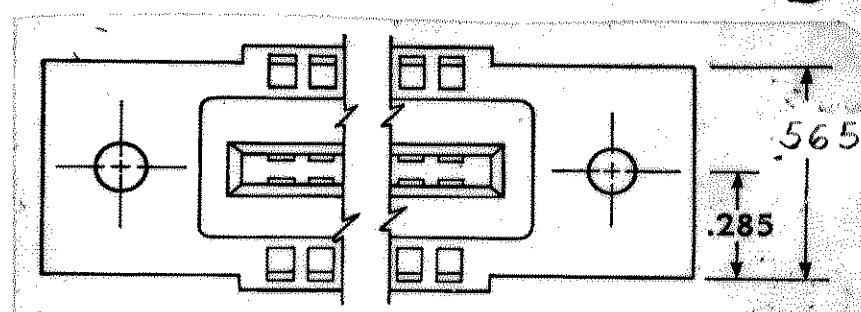

ALTERNATE MOUNTING EAR CONFIGURATION

CUSTOMER PART NO 10001-2531088 MARKED IN THIS APPROX. AREA ON SIDE 2 THRU 86 FOR -3 ONLY

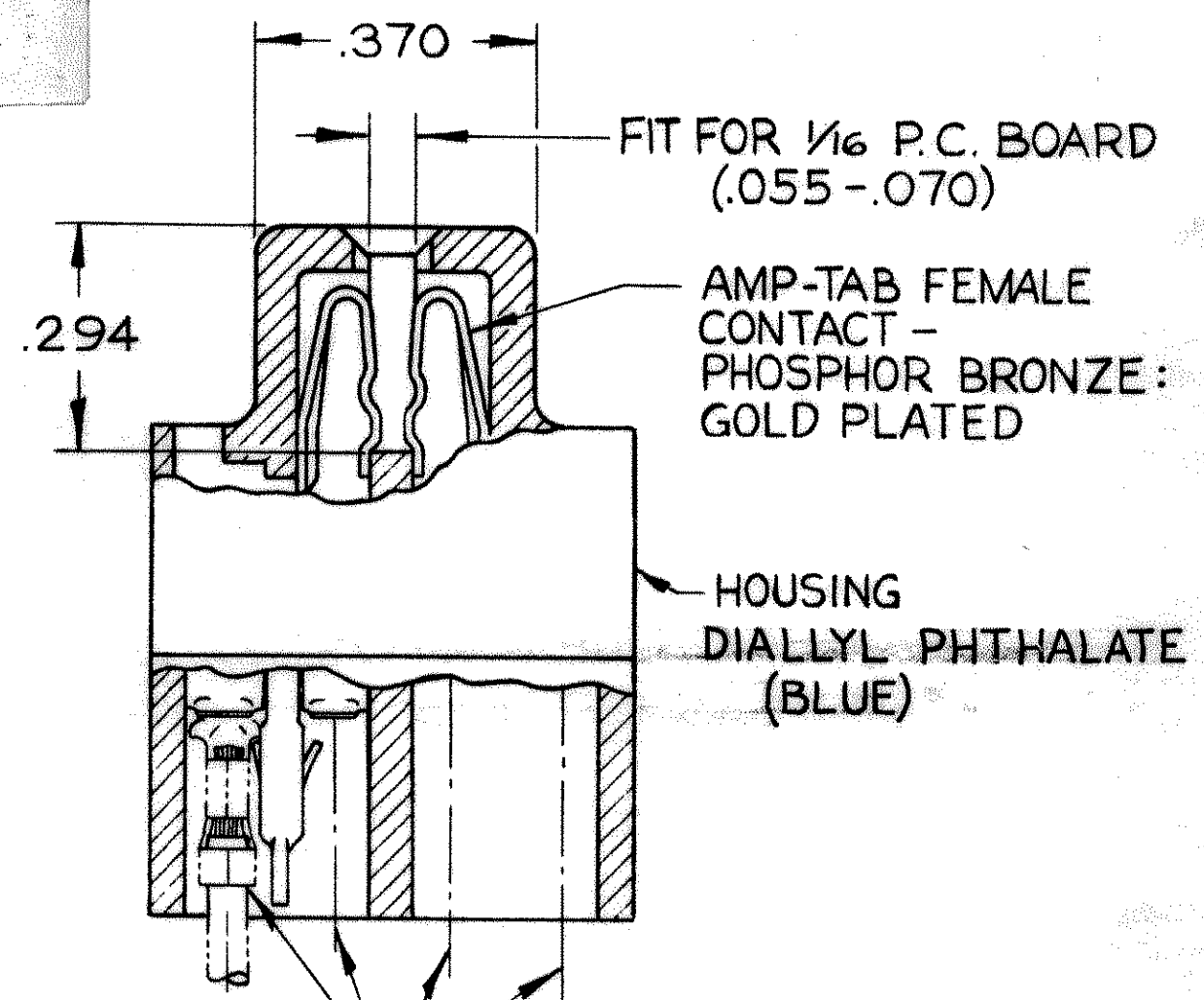

SECTION A-A

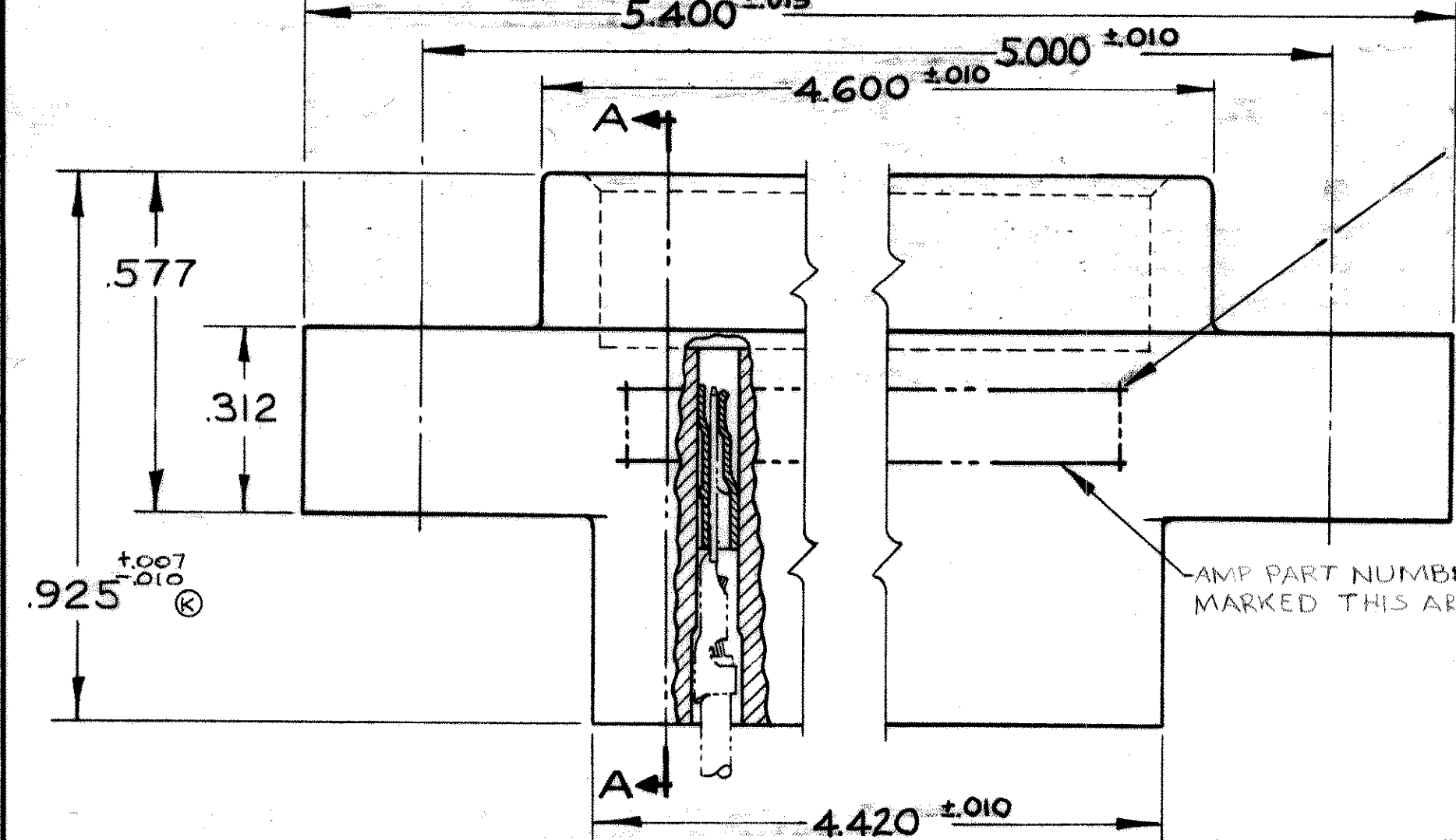

AMP PART NUMBER AND DATE CODE MARKED THIS AREA

"J" DIA. HOLES

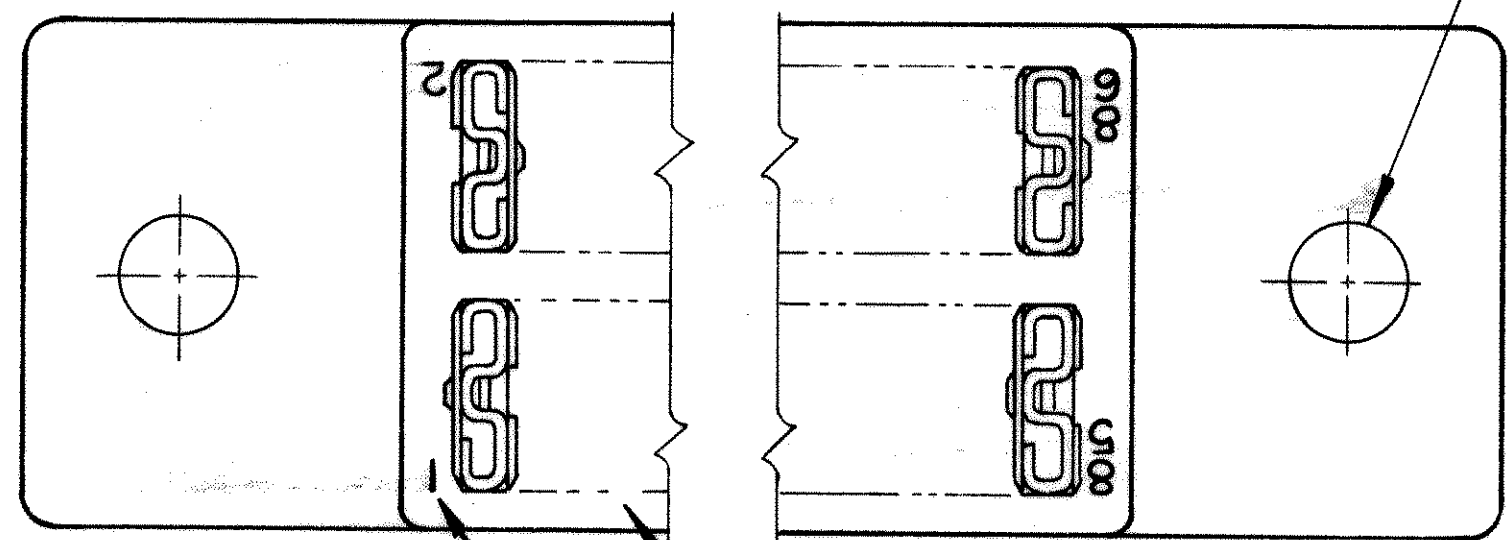

CIRCUIT CAVITY IDENTIFICATION MARKING PER MIL-C-21097

MARK FIRST 5 POSITIONS NEXT 5 POSITIONS PLAIN

3. LASER MARKING ACCEPTABLE FOR ALL MARKING

GROOVES FOR "ON CONTACT KEYING" AMP'S OPTION DEPENDING ON METHOD OF MANUFACTURE. FOR "ON CONTACT" KEYING USE KEYING PLUG P/N 583487-1. (MUST BE ORDERED SEPARATELY.)
MOUNTING EAR CONFIGURATION AMP'S OPTION DEPENDS ON METHOD OF MANUFACTURE.

UNLESS OTHERWISE SPECIFIED DIMENSIONS ARE IN INCHES TOLERANCES ON		CONTRACT NO		AMP INCORPORATED HARRISBURG, PENNSYLVANIA	
FRACTIONS ±	DECIMALS ±.005	ANGLES ±	DR <i>J. Asink</i>	DATE 12-16-66	NAME
MATERIAL	SEE CALLOUT		CHK <i>Mark Warner</i>	DATE 12-28-66	43 POSITION AMP-TAB CONNECTOR .100 CENTERS QUAD
HEAT TREAT	SEE CALLOUT		DSGN ENGR	DATE	
FINISH	SEE CALLOUT		APPD <i>J. Kaufman</i>	DATE 1-10-67	
			DSGN APPD <i>R. Shorman</i>	DATE 1/10/67	
			OTHER APPD		
SCALE 4-1	WT	CALC	ACTUAL	SHEET 1 OF 1	
SIZE C	CODE IDENT NO 00779	NUMBER 582593	REV V		

AMP INFO
LOC PRINT/DIST
DF FO

NUMBER CUS. 582593

单击下面可查看定价，库存，交付和生命周期等信息

[>>TE Connectivity\(泰科\)](#)