

REVISIONS				
REV	DATE	BY	APP'D	DESCRIPTION
G	8-5-19	CT	DM	REV PER ECO 19-010821

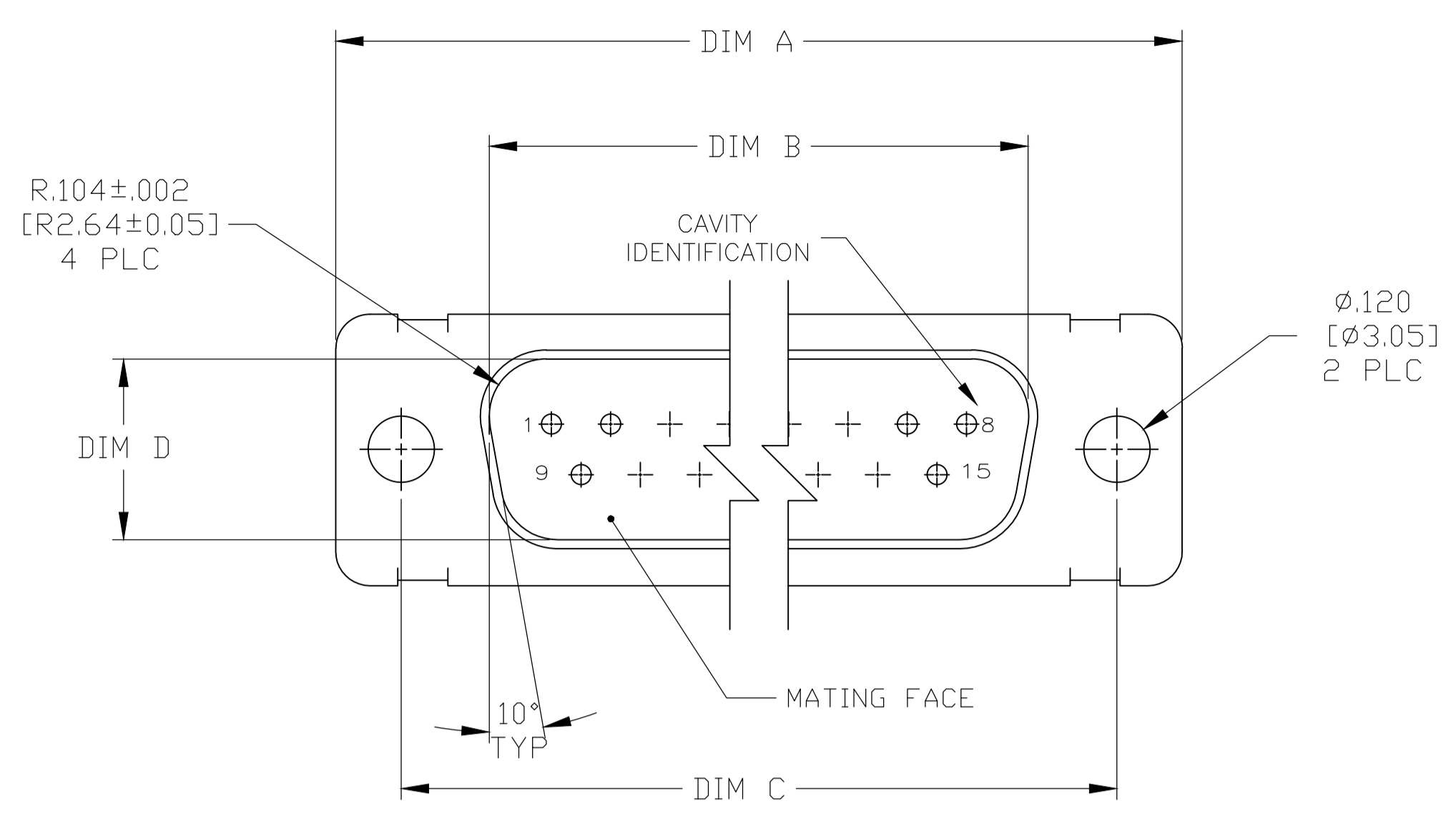

- THIS CONNECTOR ASSEMBLY IS SUPPLIED WITH Be Cu CONTACT RETENTION CLIPS INSTALLED IN THE INSERT ASSEMBLY.
- THIS CONNECTOR ASSEMBLY MATES WITH ANY RECEPTACLE CONNECTOR WITH THE SAME INSERT ARRANGEMENT AND DIMENSIONAL REQUIREMENTS PER MIL-C-24308.
- MARKED WITH .047 [1.19]-.062 [1.57] HIGH CHARACTERS. FAR SIDE REFERS TO THE WIDE SIDE OF THE KEYSTONE. NEAR SIDE REFERS TO THE NARROW SIDE OF THE KEYSTONE. IF PART IS TOO SMALL TO FIT ALL MARKING ON REAR SHELL, FAR SIDE, TE AND DATE CODE MARKED ON NEAR SIDE AND TE PART NO. MARKED ON FAR SIDE OF REAR SHELL.
- MAXIMUM WIRE INSULATION TO BE USED WITH THIS CONNECTOR ASSEMBLY IS .072 [1.83] DIAMETER.
- CLASS 0 REQUIREMENTS:  
100% INSPECTION REQUIRED:  
A. VISUAL  
B. DWV  
C. IR  
SINGLE LOT DATE CODE REQUIRED.  
SPECIAL REQUIREMENTS:  
A. TEST TWO CONNECTORS PER LOT FOR COMPLIANCE TO GROMMET PEEL STRENGTH REQUIREMENTS.  
B. TEST ALL CIRCUIT CAVITIES FOR MISALIGNMENT OR EXCESSIVE ADHESIVE.
- CLASS 1 REQUIREMENTS:  
SAME AS CLASS 0 REQUIREMENTS PLUS:  
NASA EEE-INST-002 SECTION C2 SCREENING, AS APPLICABLE.  
PPS INSERTS PER MIL-DTL-24308  
THERMAL VACUUM BAKEOUT.
- CLASS 2 REQUIREMENTS: SEE SHEET #2  
SAME AS CLASS 1 REQUIREMENTS:  
EXCEPT SHELL MATERIAL: ALUMINUM 6061-T6  
SHELL FINISH: CHEM FILM

MANUFACTURER'S NAME, BRAND OR LOGO, PART NUMBER AND DATE CODE MARKED ON FAR SIDE.

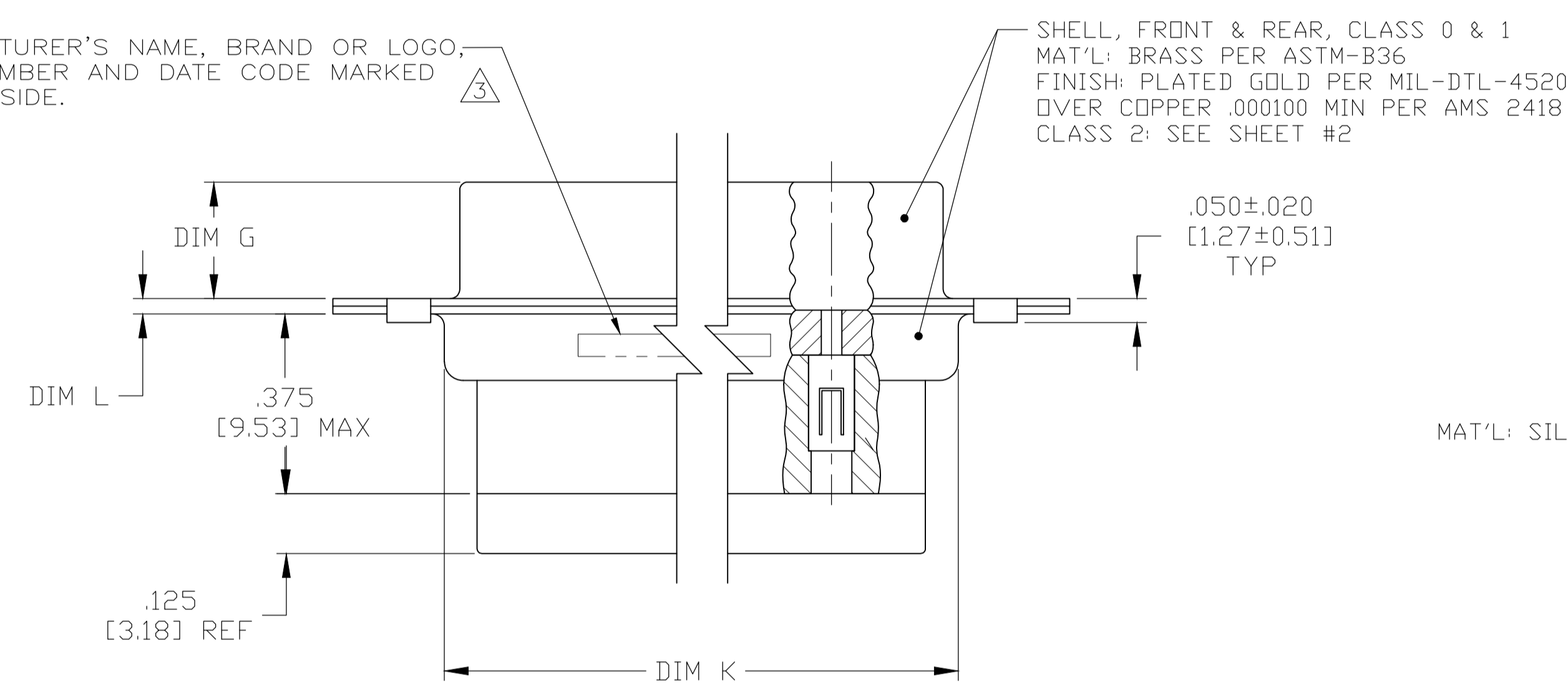

GROMMET  
MAT'L: SILICONE RUBBER  
COLOR: RED

INSERT ASSEMBLY  
MATERIAL PER MIL-DTL-24308

7	.049 .029	[1.24 0.74]	2.195 2.183	[55.57 55.45]	.556 .544	[14.12 13.82]	.236 .224	[5.99 5.69]	.535 .515	[13.59 13.08]	.620 .590	[15.75 14.99]	.446 .436	[11.33 11.07]	2.411 2.401	[61.24 60.99]	2.084 2.074	[52.93 52.68]	2.650 2.620	[67.31 66.55]	MS18277-1	50	5	1-2157916-5	1-2157916-5
7	.049 .029	[1.24 0.74]	2.290 2.278	[58.16 57.86]	.444 .432	[11.28 10.97]	.236 .224	[5.99 5.69]	.535 .515	[13.59 13.08]	.509 .479	[12.93 12.17]	.334 .324	[8.48 8.25]	2.505 2.495	[63.63 63.37]	2.187 2.177	[55.55 55.30]	2.744 2.714	[69.70 68.94]	MS18276-1	37	4	1-2157916-4	1-2157916-4
7	.049 .029	[1.24 0.74]	1.642 1.630	[41.71 41.40]	.444 .432	[11.28 10.97]	.236 .224	[5.99 5.69]	.535 .515	[13.59 13.08]	.509 .479	[12.93 12.17]	.334 .324	[8.48 8.25]	1.857 1.847	[47.17 46.91]	1.539 1.529	[39.99 38.84]	2.103 2.073	[53.42 52.65]	MS18275-1	25	3	1-2157916-3	1-2157916-3
7	.040 .020	[1.02 0.51]	1.100 1.088	[27.94 27.63]	.444 .432	[11.28 10.97]	.241 .229	[6.12 5.82]	.535 .515	[13.59 13.08]	.509 .479	[12.93 12.17]	.334 .324	[8.48 8.25]	1.317 1.307	[33.45 33.20]	.999 .989	[25.37 25.12]	1.556 1.526	[39.52 38.76]	MS18274-1	15	2	1-2157916-2	1-2157916-2
7	.040 .020	[1.02 0.51]	.776 .764	[19.71 19.41]	.444 .432	[11.28 10.97]	.241 .229	[6.12 5.82]	.535 .515	[13.59 13.08]	.509 .479	[12.93 12.17]	.334 .324	[8.48 8.25]	.989 .979	[25.12 24.87]	.671 .661	[17.04 16.79]	1.228 1.198	[31.19 30.43]	MS18273-1	9	1	1-2157916-1	1-2157916-1
6	.049 .029	[1.24 0.74]	2.188 2.168	[55.57 55.07]	.544 .524	[13.82 13.31]	.236 .224	[5.99 5.69]	.436 .416	[11.07 10.57]	.620 .590	[15.75 14.99]	.446 .436	[11.33 11.07]	2.411 2.401	[61.24 60.99]	2.084 2.074	[52.93 52.68]	2.650 2.620	[67.31 66.55]	MS18277-1	50	5	1-2157916-0	1-2157916-0
6	.049 .029	[1.24 0.74]	2.282 2.262	[57.96 57.45]	.432 .412	[10.97 10.46]	.236 .224	[5.99 5.69]	.436 .416	[11.07 10.57]	.509 .479	[12.93 12.17]	.334 .324	[8.48 8.25]	2.505 2.495	[63.63 63.37]	2.187 2.177	[55.55 55.30]	2.744 2.714	[69.70 68.94]	MS18276-1	37	4	2157916-9	2157916-9
6	.049 .029	[1.24 0.74]	1.635 1.615	[41.53 41.02]	.432 .412	[10.97 10.46]	.236 .224	[5.99 5.69]	.436 .416	[11.07 10.57]	.509 .479	[12.93 12.17]	.334 .324	[8.48 8.25]	1.857 1.847	[47.17 46.91]	1.539 1.529	[39.99 38.84]	2.103 2.073	[53.42 52.65]	MS18275-1	25	3	2157916-8	2157916-8
6	.040 .020	[1.02 0.51]	1.093 1.073	[27.76 27.25]	.432 .412	[10.97 10.46]	.241 .229	[6.12 5.82]	.432 .412	[10.97 10.46]	.509 .479	[12.93 12.17]	.334 .324	[8.48 8.25]	1.317 1.307	[33.45 33.20]	.999 .989	[25.37 25.12]	1.556 1.526	[39.52 38.76]	MS18274-1	15	2	2157916-7	2157916-7
6	.040 .020	[1.02 0.51]	.769 .749	[19.53 19.02]	.432 .412	[10.97 10.46]	.241 .229	[6.12 5.82]	.432 .412	[10.97 10.46]	.509 .479	[12.93 12.17]	.334 .324	[8.48 8.25]	.989 .979	[25.12 24.87]	.671 .661	[17.04 16.79]	1.228 1.198	[31.19 30.43]	MS18273-1	9	1	2157916-6	2157916-6
5	.049 .029	[1.24 0.74]	2.188 2.168	[55.57 55.07]	.544 .524	[13.82 13.31]	.236 .224	[5.99 5.69]	.436 .416	[11.07 10.57]	.620 .590	[15.75 14.99]	.446 .436	[11.33 11.07]	2.411 2.401	[61.24 60.99]	2.084 2.074	[52.93 52.68]	2.650 2.620	[67.31 66.55]	MS18277-1	50	5	2157916-5	2157916-5
5	.049 .029	[1.24 0.74]	2.282 2.262	[57.96 57.45]	.432 .412	[10.97 10.46]	.236 .224	[5.99 5.69]	.436 .416	[11.07 10.57]	.509 .479	[12.93 12.17]	.334 .324	[8.48 8.23]	2.505 2.495	[63.63 63.37]	2.187 2.177	[55.55 55.30]	2.744 2.714	[69.70 68.94]	MS18276-1	37	4	2157916-4	2157916-4
5	.049 .029	[1.24 0.74]	1.635 1.615	[41.53 41.02]	.432 .412	[10.97 10.46]	.236 .224	[5.99 5.69]	.436 .416	[11.07 10.57]	.509 .479	[12.93 12.17]	.334 .324	[8.48 8.23]	1.857 1.847	[47.17 46.91]	1.539 1.529	[39.99 38.84]	2.103 2.073	[53.42 52.65]	MS18275-1	25	3	2157916-3	2157916-3
5	.040 .020	[1.02 0.51]	1.093 1.073	[27.76 27.25]	.432 .412	[10.97 10.46]	.241 .229	[6.12 5.82]	.432 .412	[10.97 10.46]	.509 .479	[12.93 12.17]	.334 .324	[8.48 8.23]	1.317 1.307	[33.45 33.20]	.999 .989	[25.37 25.12]	1.556 1.526	[39.52 38.76]	MS18274-1	15	2	2157916-2	2157916-2
5	.040 .020	[1.02 0.51]	.769 .749	[19.53 19.02]	.432 .412	[10.97 10.46]	.241 .229	[6.12 5.82]	.432 .412	[10.97 10.46]	.509 .479	[12.93 12.17]	.334 .324	[8.48 8.23]	.989 .979	[25.12 24.87]	.671 .661	[17.04 16.79]	1.228 1.198	[31.19 30.43]	MS18273-1	9	1	2157916-1	2157916-1
CLASS CODE	L		K		J		G		F		E		D		C		B		A		INSERT ARRANGEMENT	NO OF POS	SHELL SIZE	MFG'S P/N ON CONNECTOR	PART NUMBER

THIS DRAWING IS A CONTROLLED DOCUMENT.

DIMENSIONS: INCHES [mm]

TOLERANCES UNLESS OTHERWISE SPECIFIED:

0 PLC ± .005 [0.13]

1 PLC ± .005 [0.13]

2 PLC ± .005 [0.13]

3 PLC ± .005 [0.13]

4 PLC ± .005 [0.13]

ANGLES ± .1°

MATERIAL: SEE CALLOUTS

FINISH: SEE CALLOUTS

WEIGHT: 0.000000

CUSTOMER DRAWING

DIN C.C. THOMAS 2-13-12

CHK: R. LEASE 2-13-12

APP'D: R. LEASE 2-13-12

NAME: AMPLIMITE NONMAGNETIC PLUG ASSY WITH GROMMET, SERIES 109 SHELL SIZES 1 THRU 5

SIZE: A1

CAGE CODE: 00779

DRAWING NO: 2157916

RESTRICTED TO: -

SCALE: 4:1

SHEET: 1 OF 2

REV: G

REVISIONS					
P	LTR	DESCRIPTION	DATE	DMN	APVD
-	-	SEE SHEET 1	-	-	-

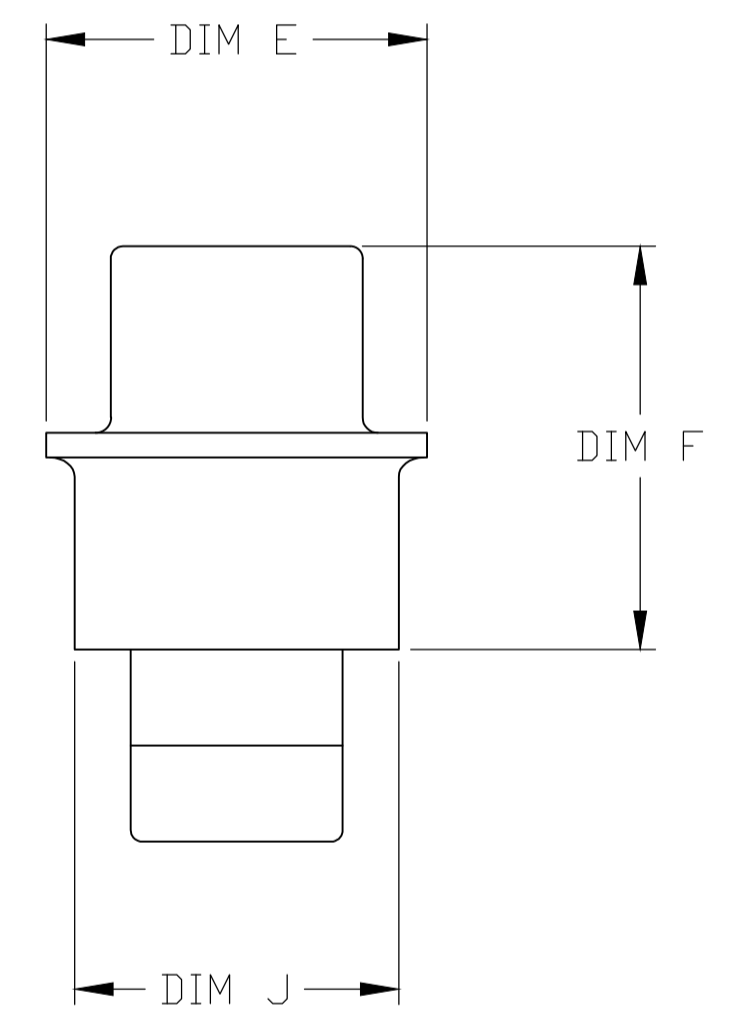
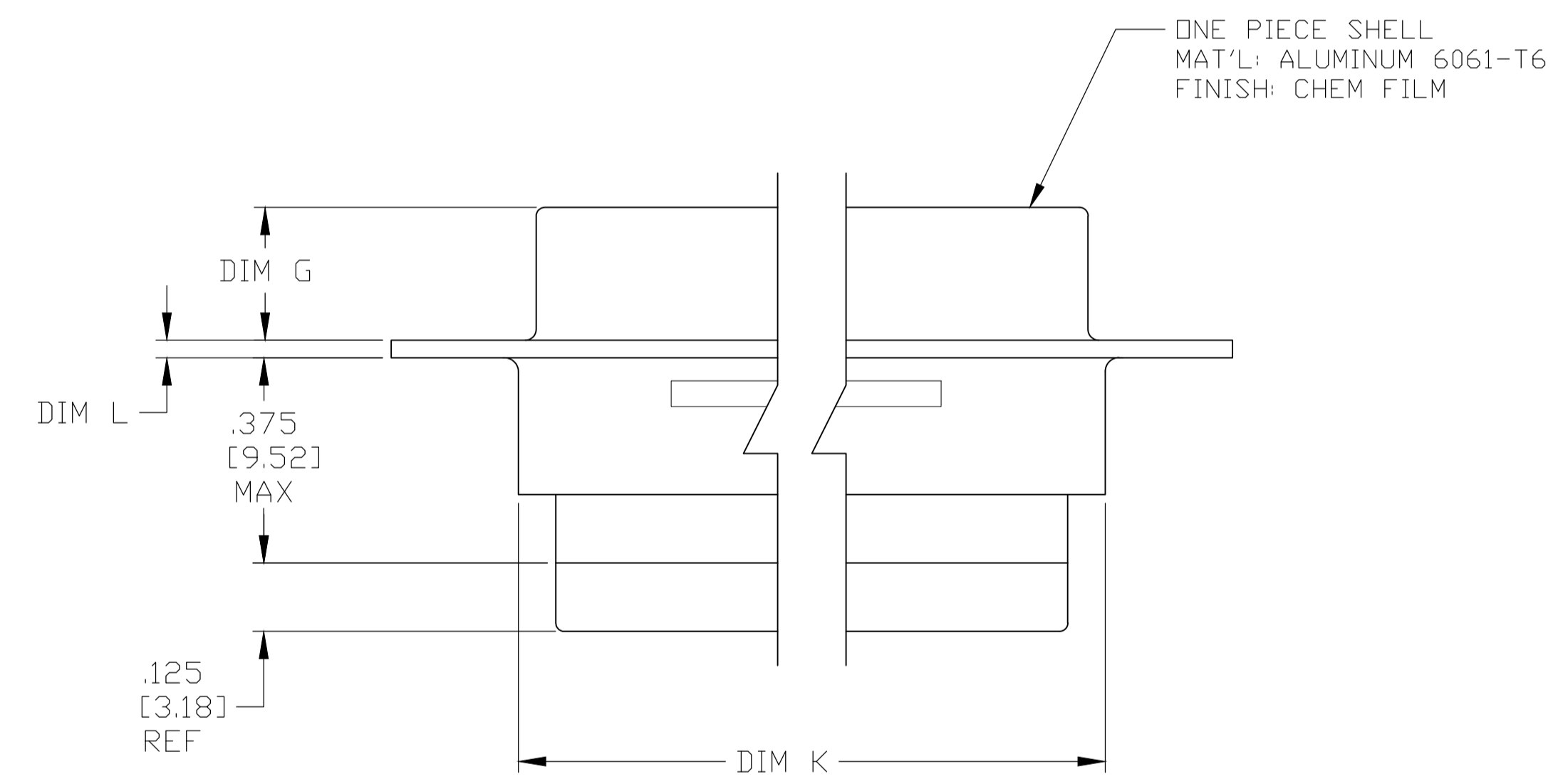
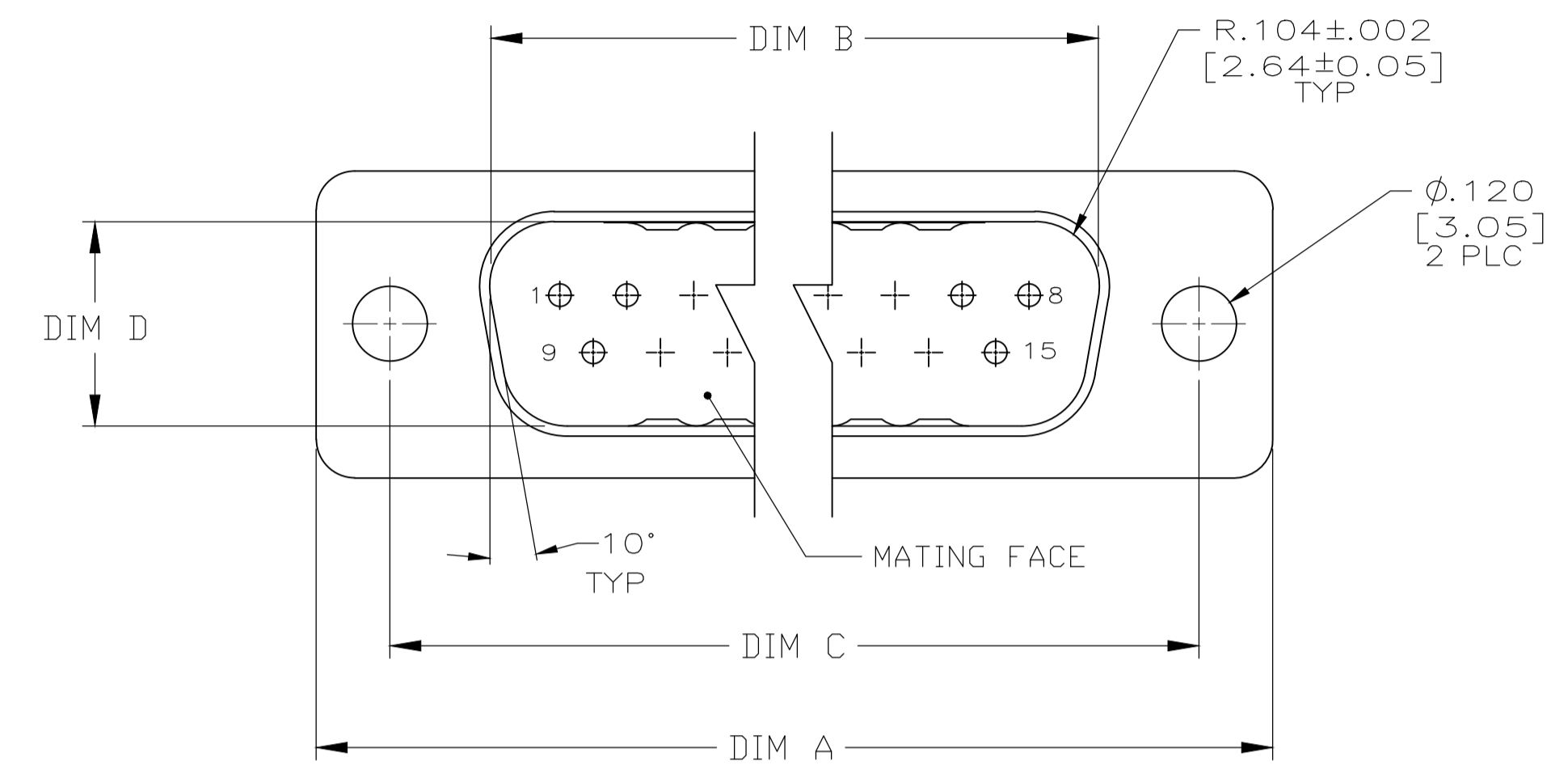

THIS DRAWING IS A CONTROLLED DOCUMENT.		DIN C.C.THOMAS 2-13-12	TE Connectivity														
DIMENSIONS: INCHES [mm]		CHK 2-13-12															
TOLERANCES UNLESS OTHERWISE SPECIFIED:		APVD RELEASE 2-13-12	NAME AMPLIMITE NONMAGNETIC PLUG ASSY WITH GROMMET, SERIES 109 SHELL SIZES 1 THRU 5														
<table border="1"> <tr> <td>0 PLC</td> <td>± .005</td> </tr> <tr> <td>1 PLC</td> <td>± .005</td> </tr> <tr> <td>2 PLC</td> <td>± .005</td> </tr> <tr> <td>3 PLC</td> <td>± .005 [0.13]</td> </tr> <tr> <td>4 PLC</td> <td>± .005</td> </tr> <tr> <td>ANGLES</td> <td>± 1°</td> </tr> </table>		0 PLC	± .005	1 PLC	± .005	2 PLC	± .005	3 PLC	± .005 [0.13]	4 PLC	± .005	ANGLES	± 1°	PRODUCT SPEC	APPLICATION SPEC		
0 PLC	± .005																
1 PLC	± .005																
2 PLC	± .005																
3 PLC	± .005 [0.13]																
4 PLC	± .005																
ANGLES	± 1°																
MATERIAL SEE CALLOUTS		FINISH SEE CALLOUTS	WEIGHT 0.000000	SIZE A1	CAGE CODE 00779												
CUSTOMER DRAWING		SCALE 4:1	SHEET 2 OF 2	REV G	RESTRICTED TO												

单击下面可查看定价，库存，交付和生命周期等信息

[>>TE Connectivity\(泰科\)](#)