

THIS DRAWING IS UNPUBLISHED.

RELEASED FOR PUBLICATION

© COPYRIGHT - TE Connectivity Ltd.

ALL RIGHTS RESERVED.

REVISIONS

P	LTR	DESCRIPTION	DATE	DWN	APVD
	B1	REVISED PER ECO-17-008114	07JUN2018	RS	DR

AMP WIRE RANGE	E13288 Listed	LR7189 Certified
22-16 AWG SOLID OR STRANDED	22-16 AWG SOLID OR STRANDED	22-16 AWG SOLID OR STRANDED

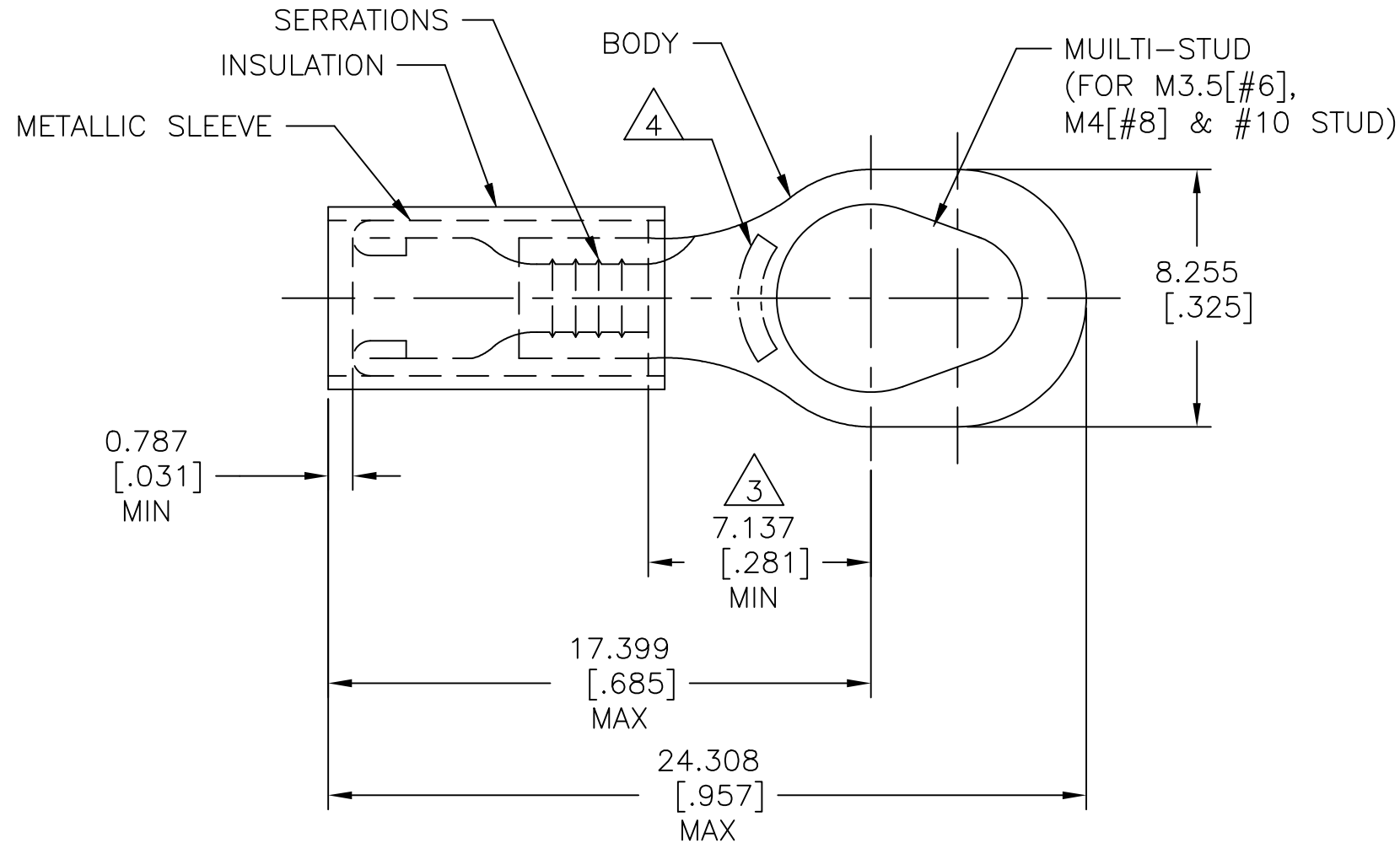

- 1 BODY MATERIAL THICKNESS: 0.787±0.051[.031±.002]
- 2 FOR 2.032 TO 3.175[.080 TO .125] WIRE INS. DIA
- 3 APPLIES FROM EDGE OF METAL WIRE BARREL TO CENTER OF #10 STUD HOLE
- 4 STAMP AMP 22-18* 1-2 APPROX AS SHOWN, 22-16 TERMINALS ARE STAMPED 22-18 IN ACCORDANCE WITH MILITARY SPEC SAE AS7928, COMMERCIAL WIRE RANGE IS 22-16
- 5 MATERIAL:
BODY & SLEEVE: COPPER PER ASTM B152
INSULATION: NYLON
- 6 FINISH:
BODY: TIN PL. PER ASTM B545
SLEEVE: NICKEL PL. PER SAE AMS QQ-N-290
INSULATION: COLOR - RED

100	LOOSE PC, BOX	8-54771-1
1000	WIRE TERMINAL	54771-1
QTY	DESCRIPTION	PART NO

AMP INCORPORATED
CUSTOMER SERVICE SYSTEMS

FOR ADDITIONAL PRODUCT INFORMATION OR COPIES OF DRAWINGS AND TECHNICAL DOCUMENTS	PRODUCT INFORMATION CENTER 1-800-522-6752
FOR APPLICATION TOOLING INFORMATION	TOOLING ASSISTANCE CENTER 1-800-722-1111
FOR ORDER ENTRY	1-800-526-5142

MAX RECOMMENDED OPERATING TEMPERATURE: 105°C[221°F]
VOLTAGE RATING: 300 V MAX
WIRE CROSS SECTIONAL AREA RANGE, 0.26-1.65mm²[509-3,260] CIR MILS SOLID OR STRANDED

THIS DRAWING IS A CONTROLLED DOCUMENT.

DIMENSIONS:
mm [INCHES]

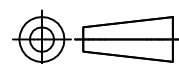

TOLERANCES UNLESS OTHERWISE SPECIFIED:	
0 PLC	± -
1 PLC	± -
2 PLC	± -
3 PLC	± 0.127[.005]
4 PLC	± -
ANGLES	± -
FINISH	



DWN	07JUN2018
CHK	RAVI S
APVD	07JUN2018
PRODUCT SPEC	ROHDE DANIEL F
APPLICATION SPEC	ROHDE DANIEL F
WEIGHT	UL 486 A-B
	114-2157
CUSTOMER DRAWING	



NAME			
TERMINAL			
P.I.D.G. - RING - MULTI - STUD			
WIRE SIZE: 22-16			
SIZE	CAGE CODE	DRAWING NO	RESTRICTED TO
A3	00779	C=54771	-
SCALE		SHEET	REV
N.T.S		1 of 1	B1

单击下面可查看定价，库存，交付和生命周期等信息

[>>TE Connectivity\(泰科\)](#)