

ELECTRICAL	
IMPEDANCE	50 Ohm
FREQUENCY RANGE	DC to 6GHz
INSERTION LOSS:	Max. 0.08dB@0-3GHz Max. 0.22dB@0-3GHz
VSWR:	Max. 1.15@0-3GHz Max. 1.35@3-6GHz
DIELECTRIC WITHSTAND VOLTAGE:	Max. 2500 V RMS
INSULATION RESISTANCE	Min. 5000 Mohms
PIM3:	Max. -16.3dBc @2x20W, 900MHz, 1800MHz, 2100MHz

MECHANICAL	
MATING CYCLES:	MIN. 100 cycles
RECOMMEND TORQUE:	5Nm

ENVIRONMENTAL	
TEMPERATURE RANGE:	-40°~+85°C
SALT SPRAY:	96H (720H FOR SPRAY AREA)
INTERFACE SEAL:	IP68(1m, 24h) MATED
PANEL SEAL:	IP67(1m, 0.5h)
HERMETIC SEAL:	PRESSURE LEAKAGE 0.25KPa MAX. (52.3KPa/30s)

P	LTR	DESCRIPTION	DATE	DWN	APVD

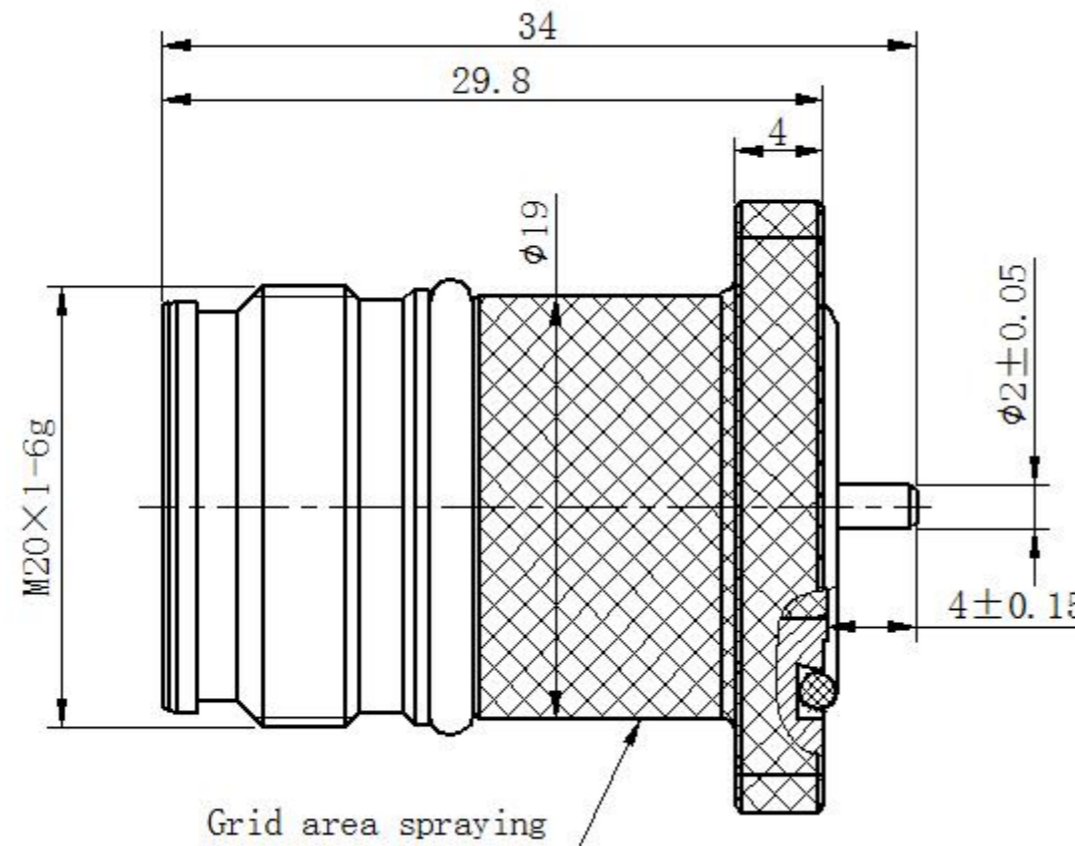
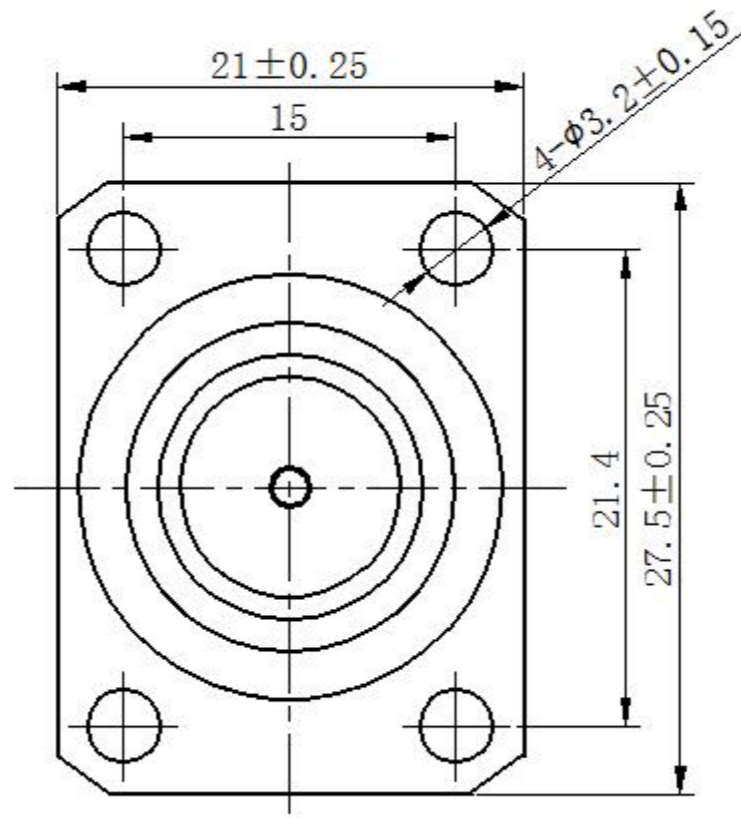

NOTE:

1. INTERFACE ACCORDING TO IEC 61169-54

P/N	PART NAME	MATERIAL	PLATING
2081977-1	CENTER CONTACT	BRONZE	SILVER
	OUTER CONTACT	BRONZE	SILVER
	BODY	BRASS	WHITE BRONZE
	INSULATOR	PTFE	
	O-RING	SILICONE RUBBER	

THIS DRAWING IS A CONTROLLED DOCUMENT.		DWN	JZ	10MAR2020	TE TE Connectivity													
DIMENSIONS: mm		CHK	RZ	10MAR2020														
TOLERANCES UNLESS OTHERWISE SPECIFIED:		APVD	RS	10MAR2020														
<table border="0"> <tr><td>0 PLC</td><td>±0.3</td></tr> <tr><td>1 PLC</td><td>±0.2</td></tr> <tr><td>2 PLC</td><td>±0.2</td></tr> <tr><td>3 PLC</td><td>±0.2</td></tr> <tr><td>4 PLC</td><td>±0.2</td></tr> <tr><td>ANGLES</td><td>±</td></tr> </table>		0 PLC	±0.3	1 PLC		±0.2	2 PLC	±0.2	3 PLC	±0.2	4 PLC	±0.2	ANGLES	±	PRODUCT SPEC	108-115175		NAME
0 PLC	±0.3																	
1 PLC	±0.2																	
2 PLC	±0.2																	
3 PLC	±0.2																	
4 PLC	±0.2																	
ANGLES	±																	
MATERIAL	SEE TABLE	FINISH	SEE TABLE	APPLICATION SPEC	-	SIZE	A3	CAGE CODE	00779	DRAWING NO	©-2081977	RESTRICTED TO	-					
CUSTOMER DRAWING		WEIGHT	48.5g		SCALE	1:1		SHEET	1 OF 2		REV	A						

P	LTR	DESCRIPTION	DATE	DWN	APVD

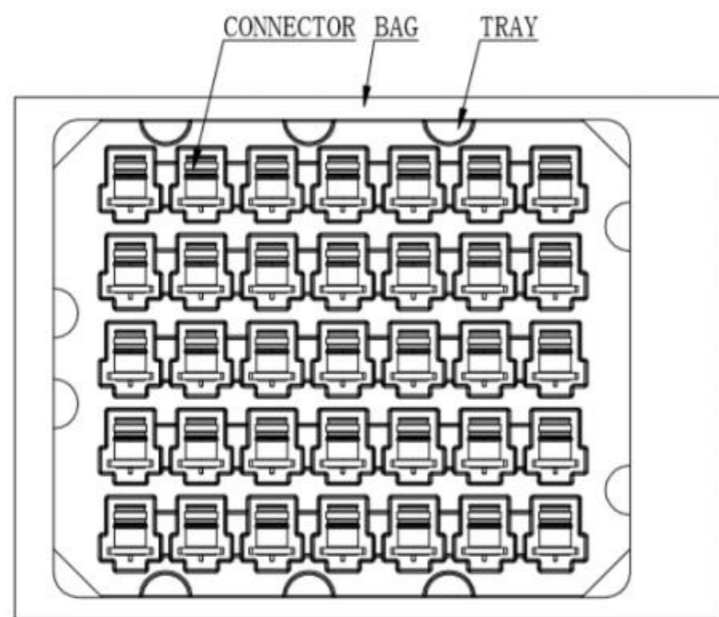

TRAY PACKAGE

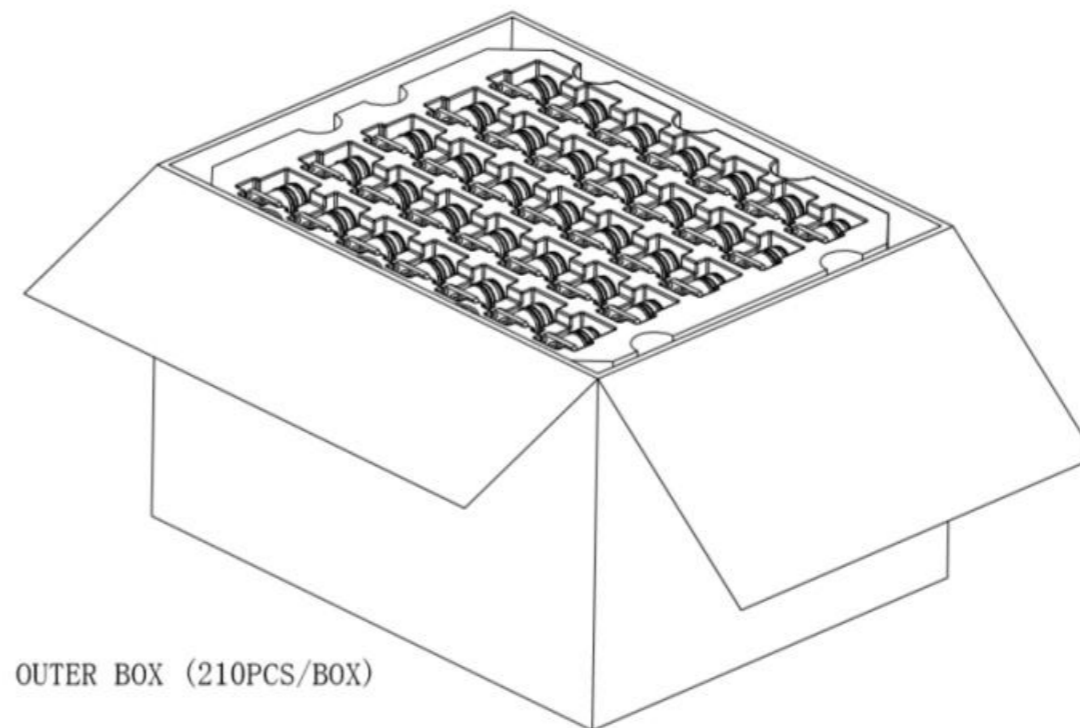
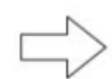

OUTER BOX (210PCS/BOX)

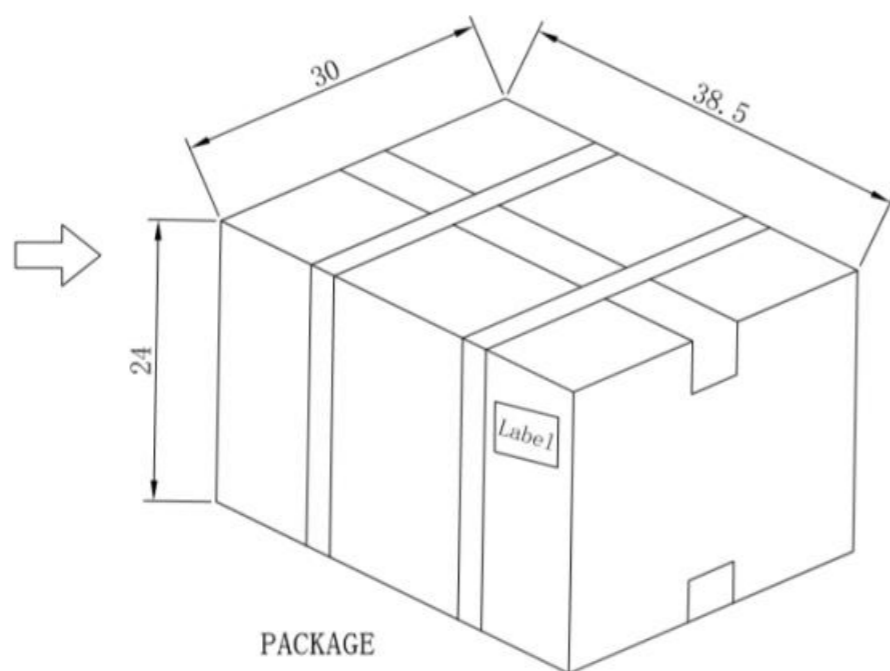

PACKAGE

(BOX SIZE ONLY FOR REFERENCE, UNIT: CM)

THIS DRAWING IS A CONTROLLED DOCUMENT.		DWN JZ	10MAR2020		
DIMENSIONS: mm		CHK RZ	10MAR2020		
TOLERANCES UNLESS OTHERWISE SPECIFIED:		APVD RS	10MAR2020	NAME 4.3-10 STRAIGHT JACK RECEPTACLE 4 HOLES SQUARE FLANGE, SPRAY WITH O-RING	
		PRODUCT SPEC 108-115175		SIZE A3	
MATERIAL SEE TABLE		APPLICATION SPEC -		CAGE CODE 00779	DRAWING NO C-2081977
FINISH SEE TABLE		WEIGHT 48.5g		RESTRICTED TO -	
-		CUSTOMER DRAWING		SCALE 1:1	SHEET 2 OF 2
-		-		REV A	

单击下面可查看定价，库存，交付和生命周期等信息

[>>TE Connectivity\(泰科\)](#)