

THIS DRAWING IS UNPUBLISHED. RELEASED FOR PUBLICATION  
 © COPYRIGHT BY TYCO ELECTRONICS CORPORATION. ALL INTERNATIONAL RIGHTS RESERVED.

LOC	DIST	REVISIONS					
		P	LTR	DESCRIPTION	DATE	DWN	APVD
-	-	C1		REVISED PER ECO-09-017426	8/28/09	SS	CR
		C2		REVISED PER ECO-09-027197	09DEC09	KK	AEG

- 1 MATERIALS AND FINISH  
 HOUSING: PA 6-6, UL 94-V0, COLOR: GREEN.  
 CLAMP: BRASS, NICKEL PLATED.  
 CONTACT: PHOSPHOR BRONZE, TIN PLATED.  
 CLAMPING SCREW: M3, BRASS, NICKEL PLATED.
- 2. WIRE SIZE RANGE: 12-30 AWG
- 3. RECOGNIZED UNDER THE COMPONENT PROGRAM OF UNDERWRITERS LABORATORIES INC. FILE NO. E60677.
- 4. IMQ CERTIFICATE WITH SURVEILLANCE IN CONFORMITY WITH IEC 998-1/998-2-1.
- 5 NOT CUMULATIVE TOLERANCE.
- 6 OBSOLETE PARTS: OBSOLETE CIS STREAMLINING PER D.RENAUD/D.SINISI

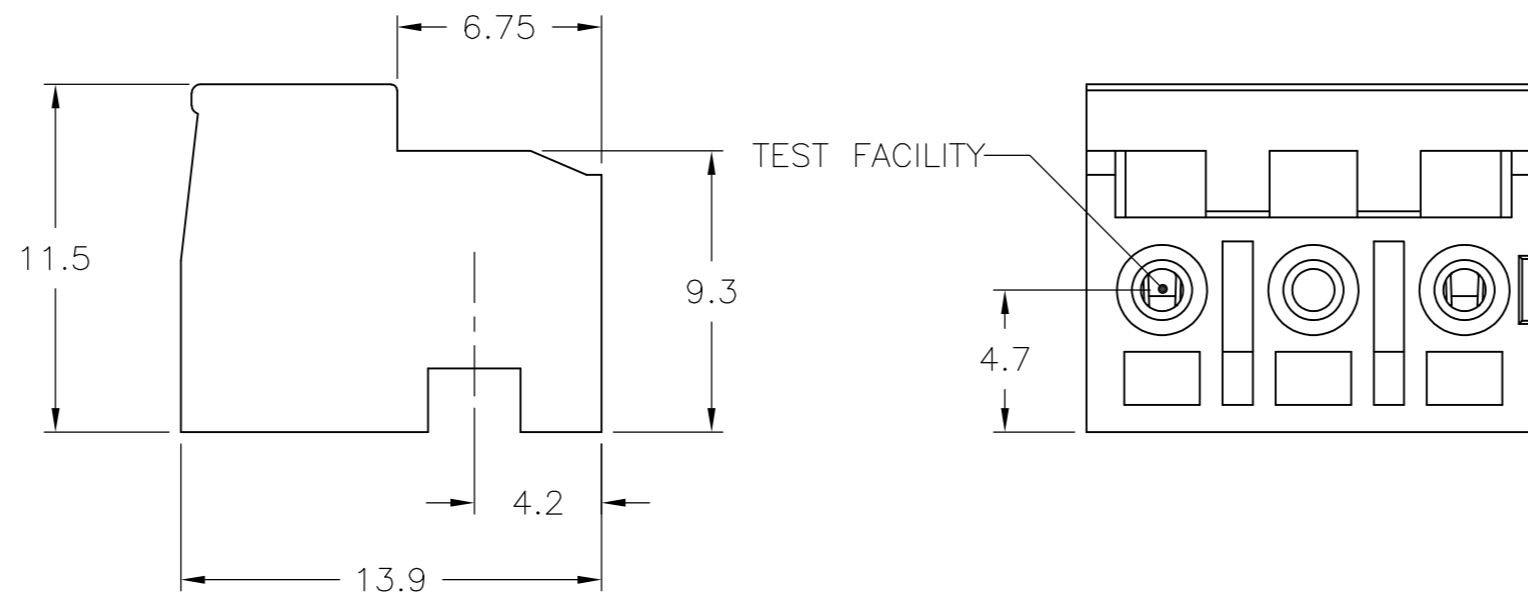
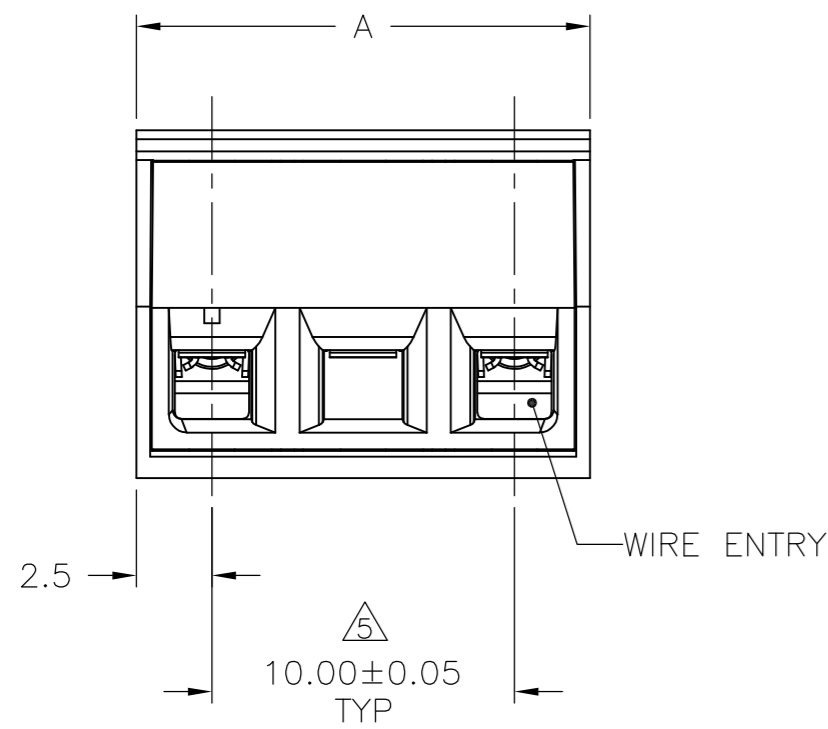
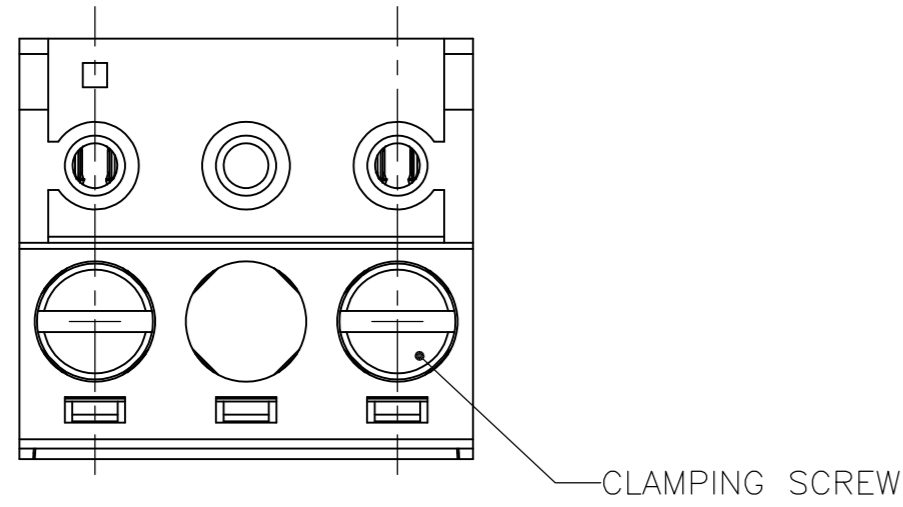

OBSOLETE	55	6	282831-6
	45	5	282831-5
	35	4	282831-4
	25	3	282831-3
	15	2	282831-2
A	NO OF POSN	PART NUMBER	

THIS DRAWING IS A CONTROLLED DOCUMENT.		DWN S SCHLEGEL 28AUG2009	Tyco Electronics Corporation Harrisburg, PA 17105-3608	
DIMENSIONS: mm		CHK C RICHARD 8/28/09	NAME C RICHARD 8/28/09	
TOLERANCES UNLESS OTHERWISE SPECIFIED: 0 PLC ± - 1 PLC ± 0.3 2 PLC ± 0.25 3 PLC ± - 4 PLC ± - ANGLES ± 1°		APVD C RICHARD 8/28/09	PRODUCT SPEC APPLICATION SPEC	
MATERIAL - △		FINISH - △	WEIGHT -	SIZE A2
CUSTOMER DRAWING		CAGE CODE 00779	DRAWING NO C=282831	RESTRICTED TO -
		SCALE 4:1	SHEET 1 OF 1	REV C2

单击下面可查看定价，库存，交付和生命周期等信息

[>>TE Connectivity\(泰科\)](#)