

REVISIONS					
P	LTR	DESCRIPTION	DATE	DWN	APVD
	E1	REV PER ECR 07-014387	19JUN07	JR	TM
	F	REVISED PER ECO-17-001534	08MAY2017	RS	DR

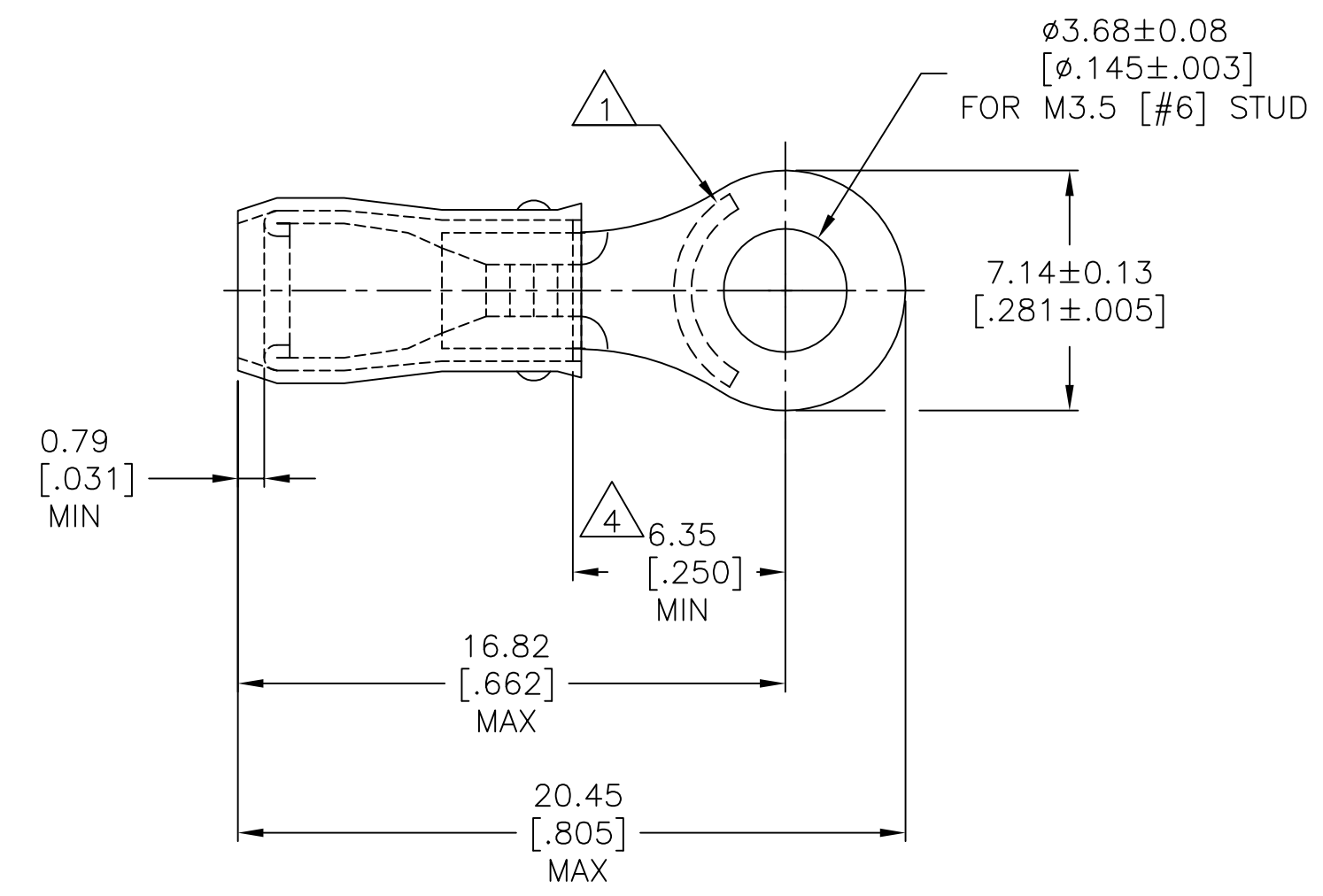

- 1 STAMP AMP 18-16, APPROX AS SHOWN.
- 2 WIRE INSULATION DIA IS  $\phi 1.4-2.8\text{mm}$  [ $\phi 0.055-.110$ ].
- 3 TONGUE MATERIAL THICKNESS IS  $0.79\pm 0.05$  [ $0.031\pm 0.002$ ].
- 4 APPLIES FROM EDGE OF WIRE BARREL TO CENTER OF STUD HOLE.
- 5 MATERIAL: BODY - COPPER PER ASTM B-152 SLEEVE - NYLON.
- 6 FINISH: BODY - TIN PLATE PER ASTM B-545 SLEEVE - COLOR, ORANGE.

1000	LOOSE PIECE	152884
QTY	PACKAGE TYPE	PART NO.

AMP INCORPORATED CUSTOMER SERVICE SYSTEMS		MAX RECOMMENDED OPERATING TEMPERATURE: 105°C [221°F]	THIS DRAWING IS A CONTROLLED DOCUMENT.		DWN JR RUTH 19JUN2007	TE Connectivity NAME TERMINAL, RING TONGUE, PIDG, WIRE SIZE: 18-16 AWG			
FOR ADDITIONAL PRODUCT INFORMATION OR COPIES OF DRAWINGS AND TECHNICAL DOCUMENTS	PRODUCT INFORMATION CENTER 1-800-522-6752	VOLTAGE RATING: 300 V MAX	DIMENSIONS: mm [INCHES]	TOLERANCES UNLESS OTHERWISE SPECIFIED:	CHK T MICHELUTTI 19JUN07				
FOR APPLICATION TOOLING INFORMATION	TOOLING ASSISTANCE CENTER 1-800-722-1111	CIRCULAR MIL AREA: 0.81-1.65mm² [1600-3260] SOLID OR STRANDED		0 PLC ± - 1 PLC ± - 2 PLC ± 0.20 [.008] 3 PLC ± - 4 PLC ± - ANGLES ± -	APVD T MICHELUTTI 19JUN07	CAGE CODE			
FOR ORDER ENTRY	1-800-526-5142	THIS DRAWING IS A CONTROLLED DOCUMENT FOR AMP INCORPORATED. IT IS SUBJECT TO CHANGE AND THE CONTROLLING ENGINEERING ORGANIZATION SHOULD BE CONTACTED FOR THE LATEST REVISION.	MATERIAL	FINISH	PRODUCT SPEC		DRAWING NO		RESTRICTED TO
			5	6	APPLICATION SPEC		A3 00779 C=152884		
					WEIGHT		SCALE		SHEET
					-		5:1		1 OF 1
					CUSTOMER DRAWING		REV		F

单击下面可查看定价，库存，交付和生命周期等信息

[>>TE Connectivity\(泰科\)](#)