

LOC		DIST		REVISONS			
GP	00	P	LTN	DESCRIPTION	DATE	DWN	APVD
		A		RELEASED	25FEB2016	JW	SH

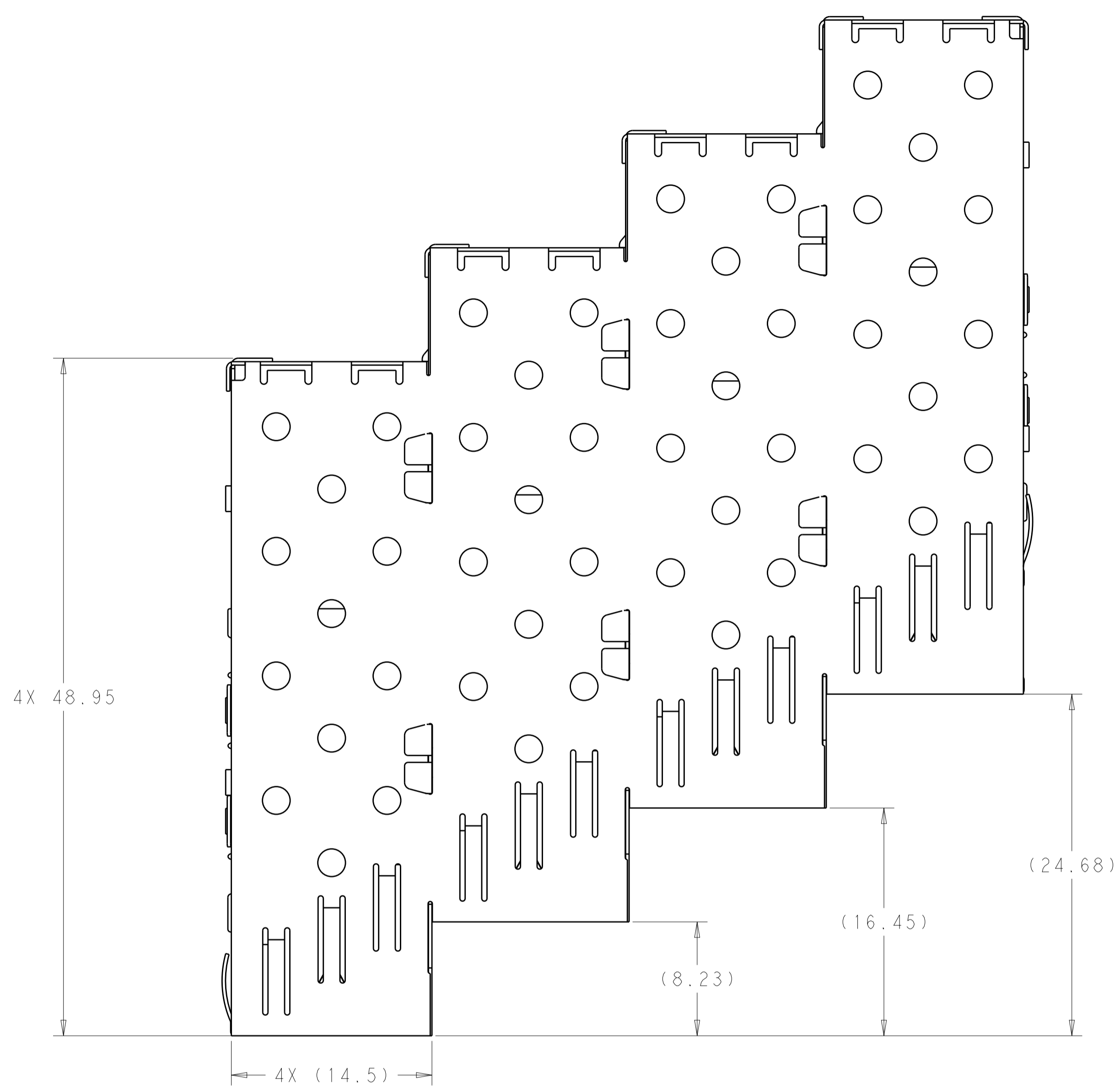

- 1 MATERIAL: 0.25mm THICK NICKEL SILVER ALLOY.
- 2 DATUM AND BASIC DIMENSIONS ESTABLISHED BY THE CUSTOMERS.
- 3. MATES WITH MSA COMPLIANT TRANSIEVERS.
- 4 PADS AND VIAS CHASSIS GROUND.
- 5 REFERENCE APPLICATION SPEC 114-13120, HOLE A, FOR RECOMMENDED DRILL HOLE DIAMETER AND PLATING THICKNESS.
- 6 MINIMUM PCB THICKNESS:  
SINGLE SIDED = 1.5mm

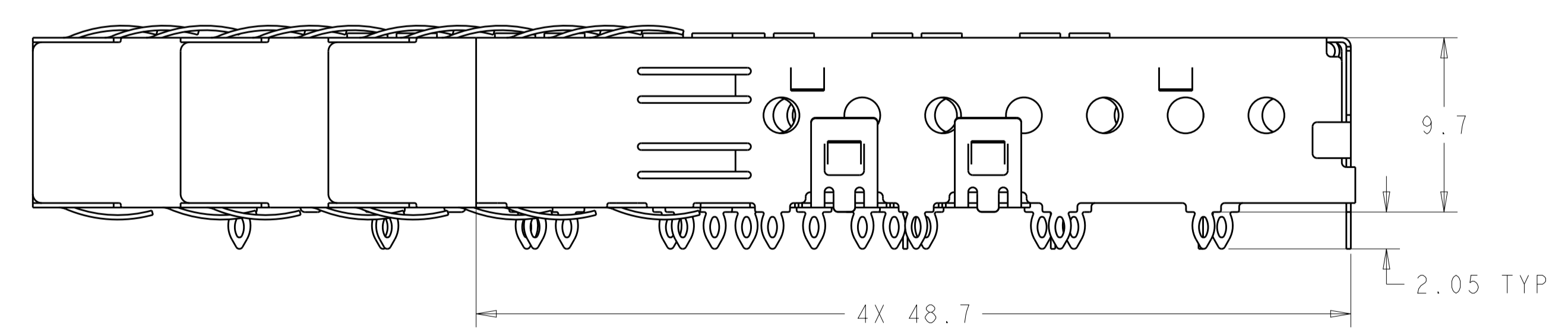
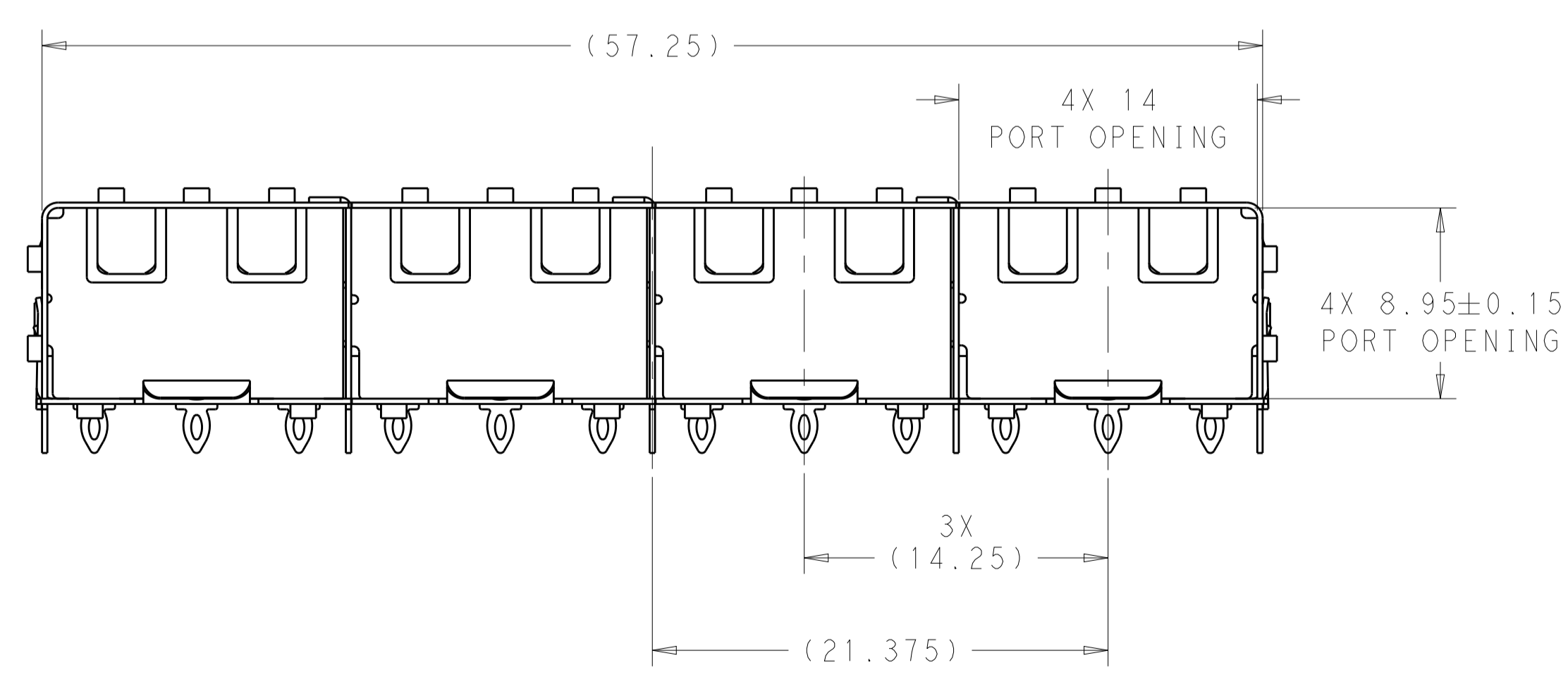
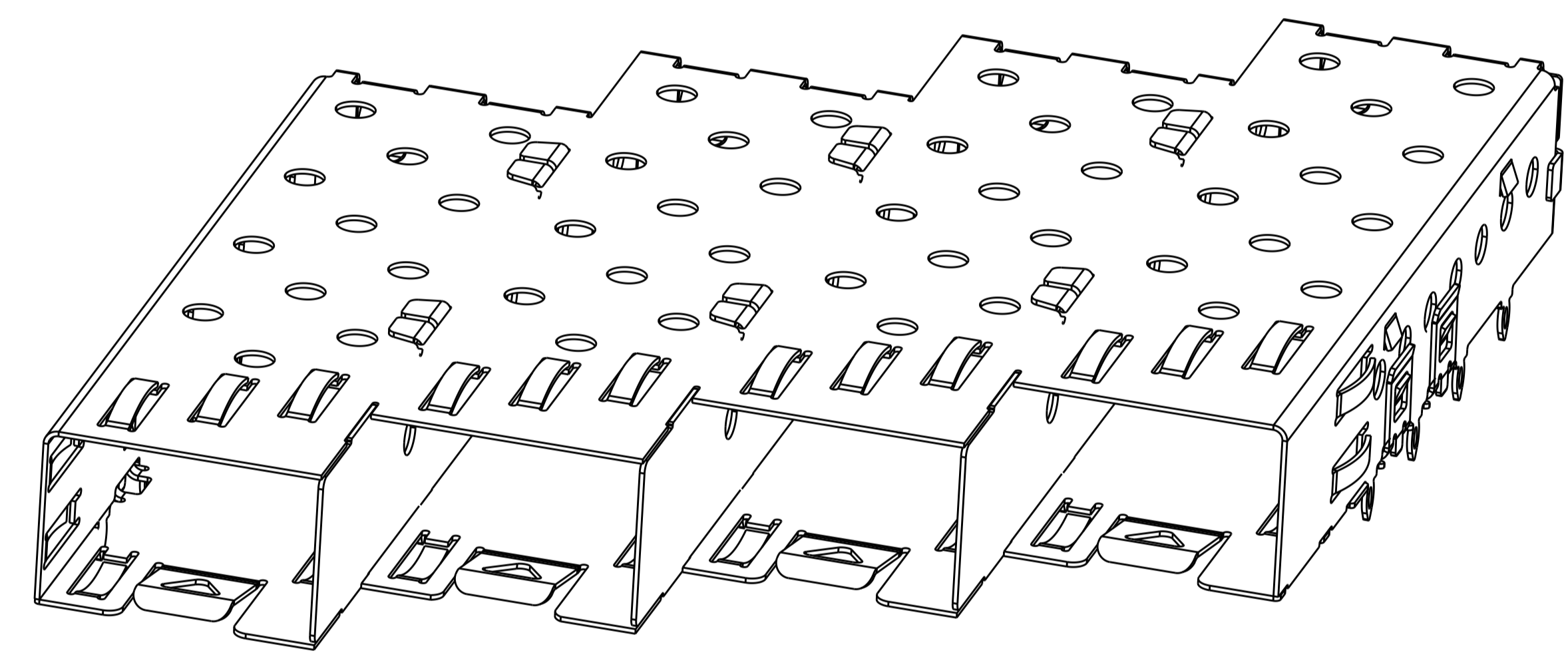

2170167-1  
PART NO.

THIS DRAWING IS A CONTROLLED DOCUMENT.		DWN: JASON YANG 08NOV2011	TE Connectivity NAME: SFP, 1X4 CAGE ASSEMBLY, 30 DEGREE, PRESS FIT SIZE: CAGE CODE DRAWING NO: A100779C=2170167 RESTRICTED TO:
DIMENSIONS: mm		CHK: ALEX CAI 08NOV2011	
TOLERANCES UNLESS OTHERWISE SPECIFIED:		APVD: ALEX CAI 08NOV2011	
0 PLC ±0.2 1 PLC ±0.2 2 PLC ±0.2 3 PLC ±0.2 4 PLC ±0.2 ANGLES ±0.2		PRODUCT SPEC: 108-1950 APPLICATION SPEC: 114-13120 WEIGHT:	
MATERIAL: FINISH:		CUSTOMER DRAWING	SCALE: 4:1 SHEET 1 OF 3 REV A

LOC		DIST		REVISIONS			
GP	00	P	LTH	DESCRIPTION	DATE	DWN	APVD
-	-	-	-	SEE SHEET 1	-	-	-

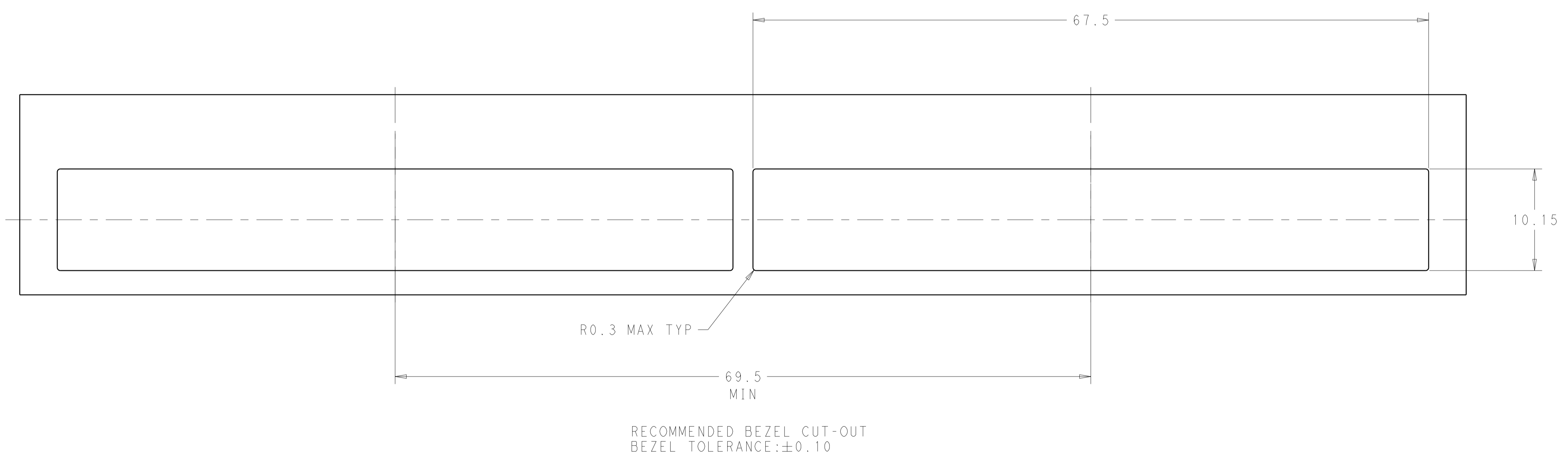
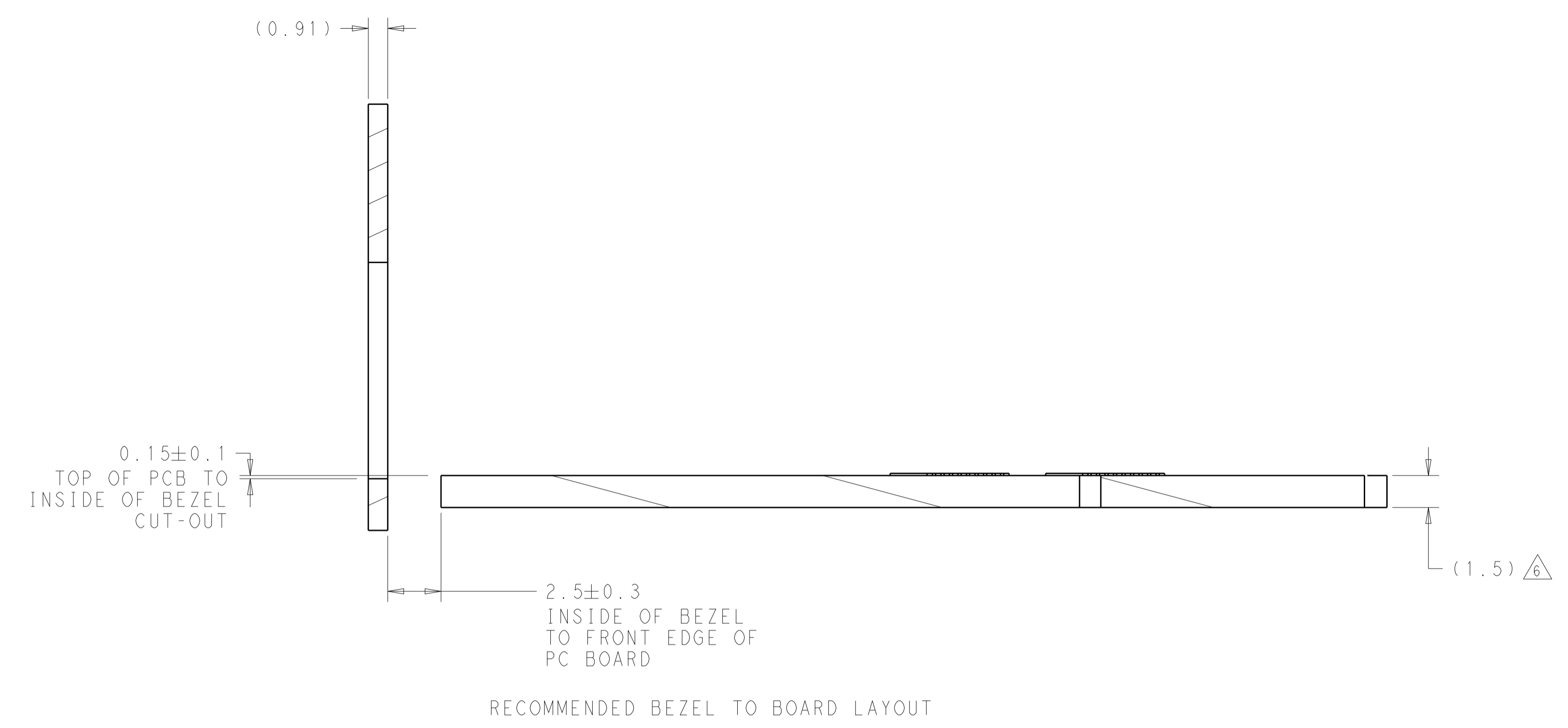

THIS DRAWING IS A CONTROLLED DOCUMENT.		DWN	JASON YANG	08NOV2011	TE Connectivity
DIMENSIONS:		CHK	ALEX CAI	08NOV2011	
mm		APVD	ALEX CAI	08NOV2011	
		TOLERANCES UNLESS OTHERWISE SPECIFIED:		NAME	
0 PLC	±0.2	PRODUCT SPEC		SFP, 1X4 CAGE ASSEMBLY, 30 DEGREE, PRESS FIT	
1 PLC	±0.2	108-1950		SIZE	
2 PLC	±0.2	APPLICATION SPEC		CAGE CODE	
3 PLC	±0.2	114-13120		DRAWING NO	
4 PLC	±0.2	WEIGHT		RESTRICTED TO	
ANGLES	±0.2	CUSTOMER DRAWING		A100779C=2170167	
MATERIAL	-	SCALE		4:1	
FINISH	-	SHEET		2 OF 3	
		REV		A	

LOC	DIST	REV	DATE	BY	APPD
GP	00				

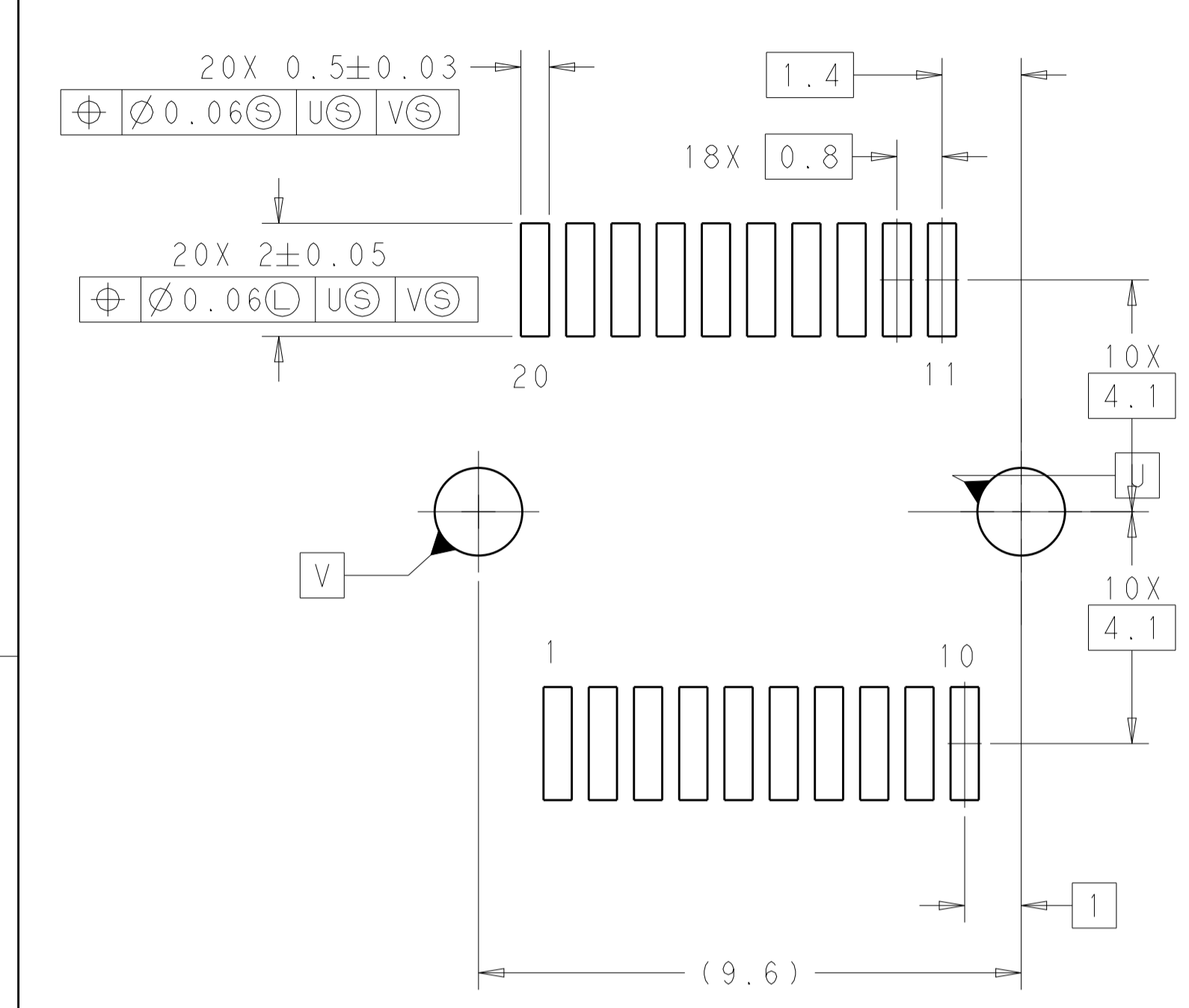

DETAIL A  
RECOMMENDED PT CONNECTOR LAYOUT  
4X INDIVIDUALLY  
SCALE 10:1

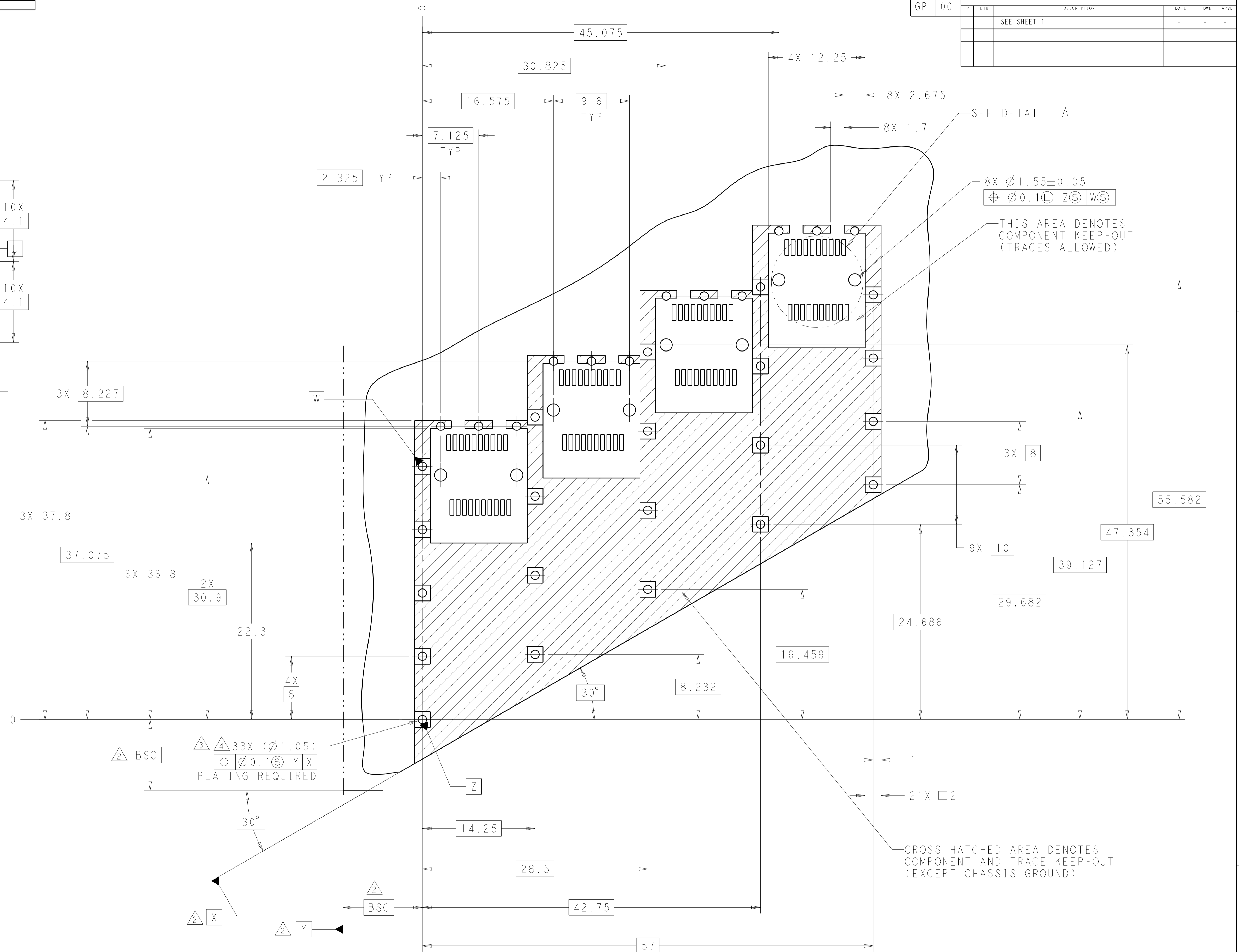

RECOMMENDED PCB CONFIGURATION  
WITH KEEP-OUT AREAS  
PCB TOLERANCE: ±0.05  
SINGLE SIDED APPLICATIONS

CROSS HATCHED AREA DENOTES  
COMPONENT AND TRACE KEEP-OUT  
(EXCEPT CHASSIS GROUND)

THIS DRAWING IS A CONTROLLED DOCUMENT.		DWN: JASON YANG 08NOV2011 CHK: ALEX CAI 08NOV2011 APVD: ALEX CAI 08NOV2011	<b>STE</b> TE Connectivity	
DIMENSIONS: mm 	TOLERANCES UNLESS OTHERWISE SPECIFIED: 0 PLC ±0.2 1 PLC ±0.2 2 PLC ±0.2 3 PLC ±0.2 4 PLC ±0.2 ANGLES ±0.2	NAME: SFP, 1X4 CAGE ASSEMBLY, 30 DEGREE, PRESS FIT PRODUCT SPEC: 108-1950 APPLICATION SPEC: 114-13120	SIZE: A100779 CAGE CODE: C=2170167	RESTRICTED TO: - SCALE: 4:1 SHEET: 3 OF 3 REV: A
MATERIAL: -		WEIGHT: - FINISH: -	CUSTOMER DRAWING	

单击下面可查看定价，库存，交付和生命周期等信息

[>>TE Connectivity\(泰科\)](#)