

THIS DRAWING IS UNPUBLISHED. RELEASED FOR PUBLICATION 20
 © COPYRIGHT 20 BY TYCO ELECTRONICS CORPORATION. ALL RIGHTS RESERVED.

REVISIONS							
LOC	DIST	P	LTR	DESCRIPTION	DATE	DWN	APVD
-	-	A		REVISED PER ECO-09-017978	19AUG2009	SS	MS

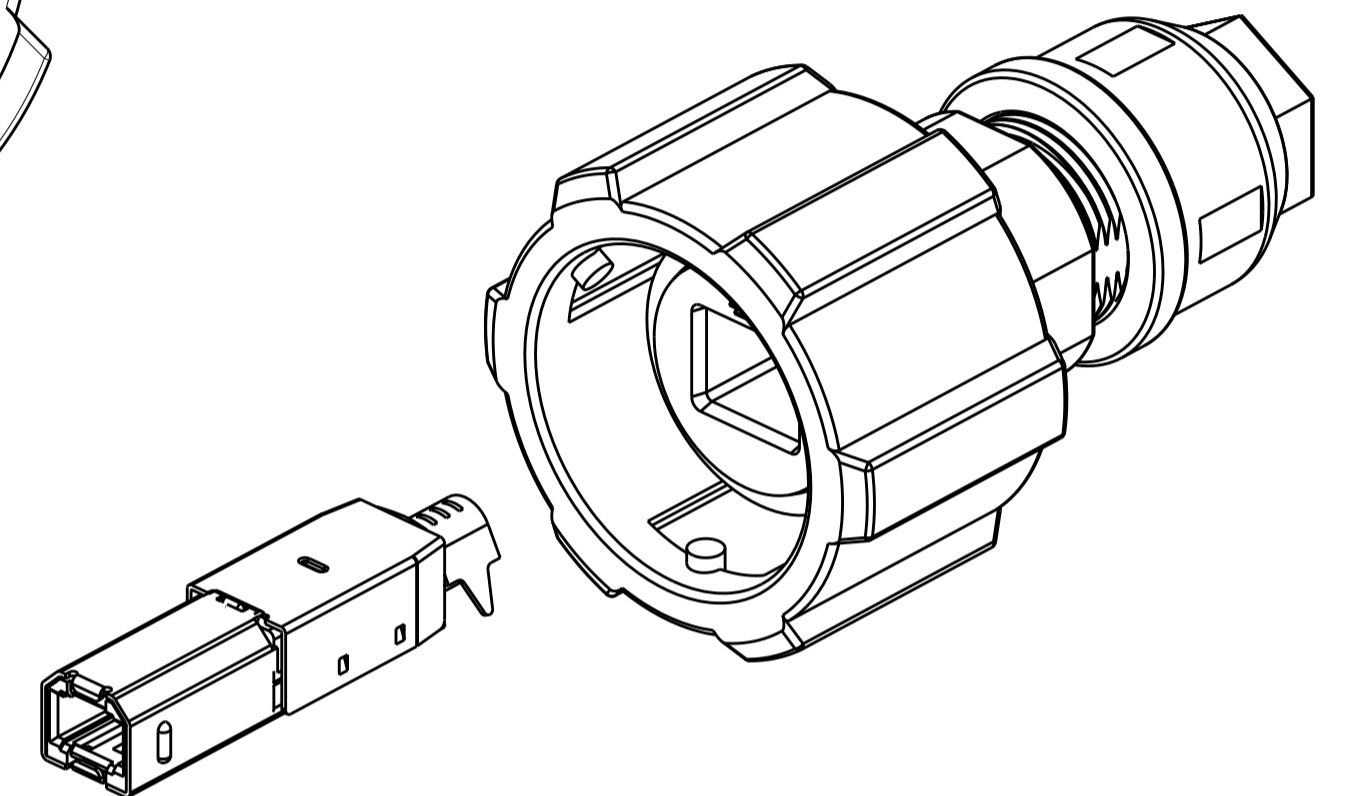

SCALE 2:1

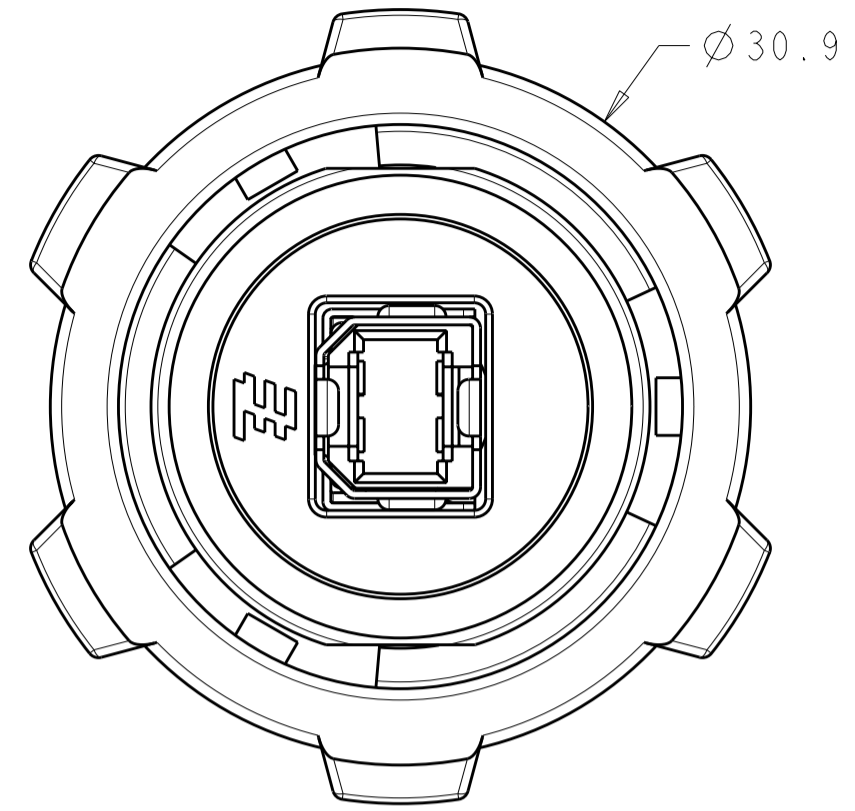
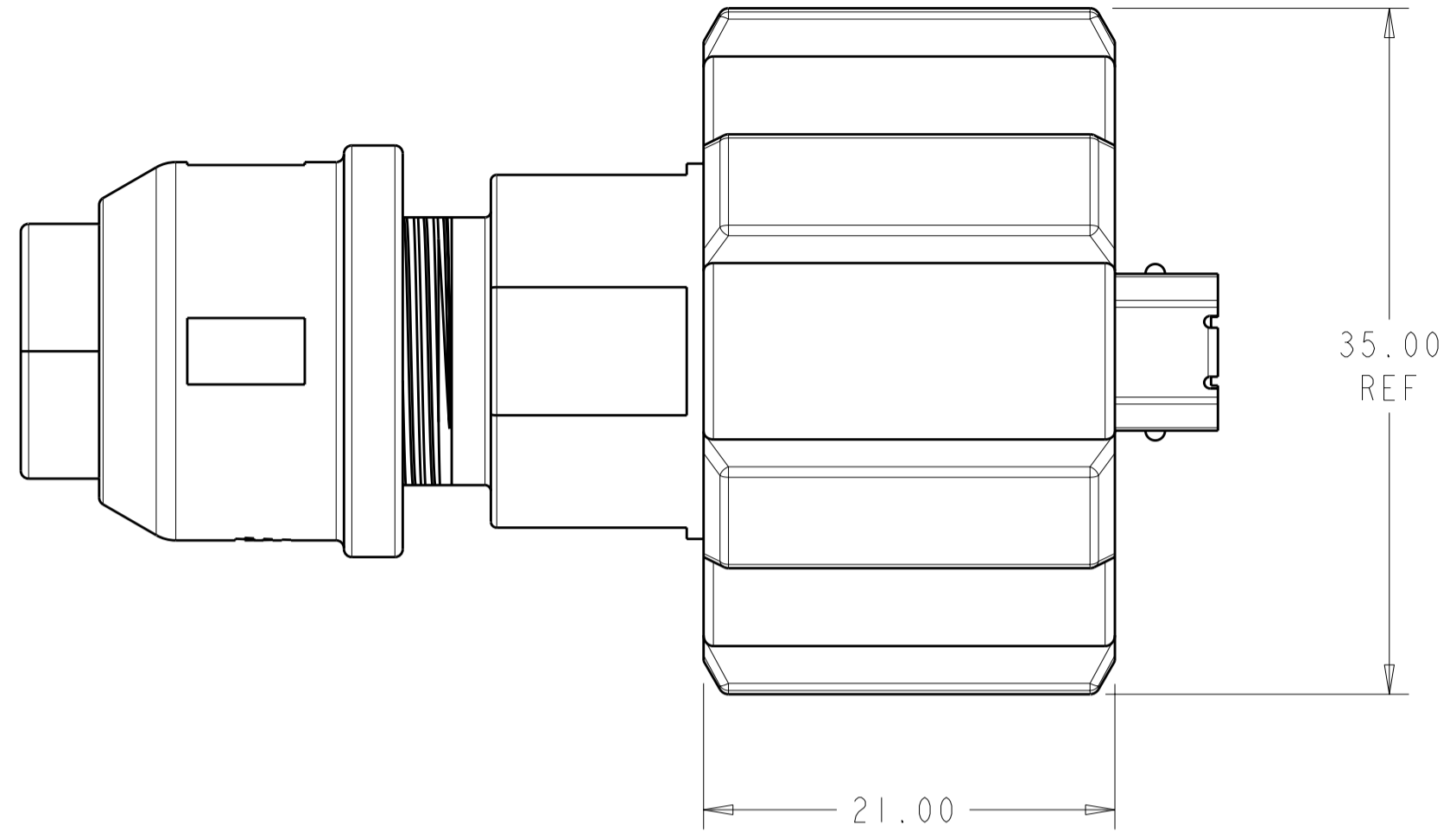
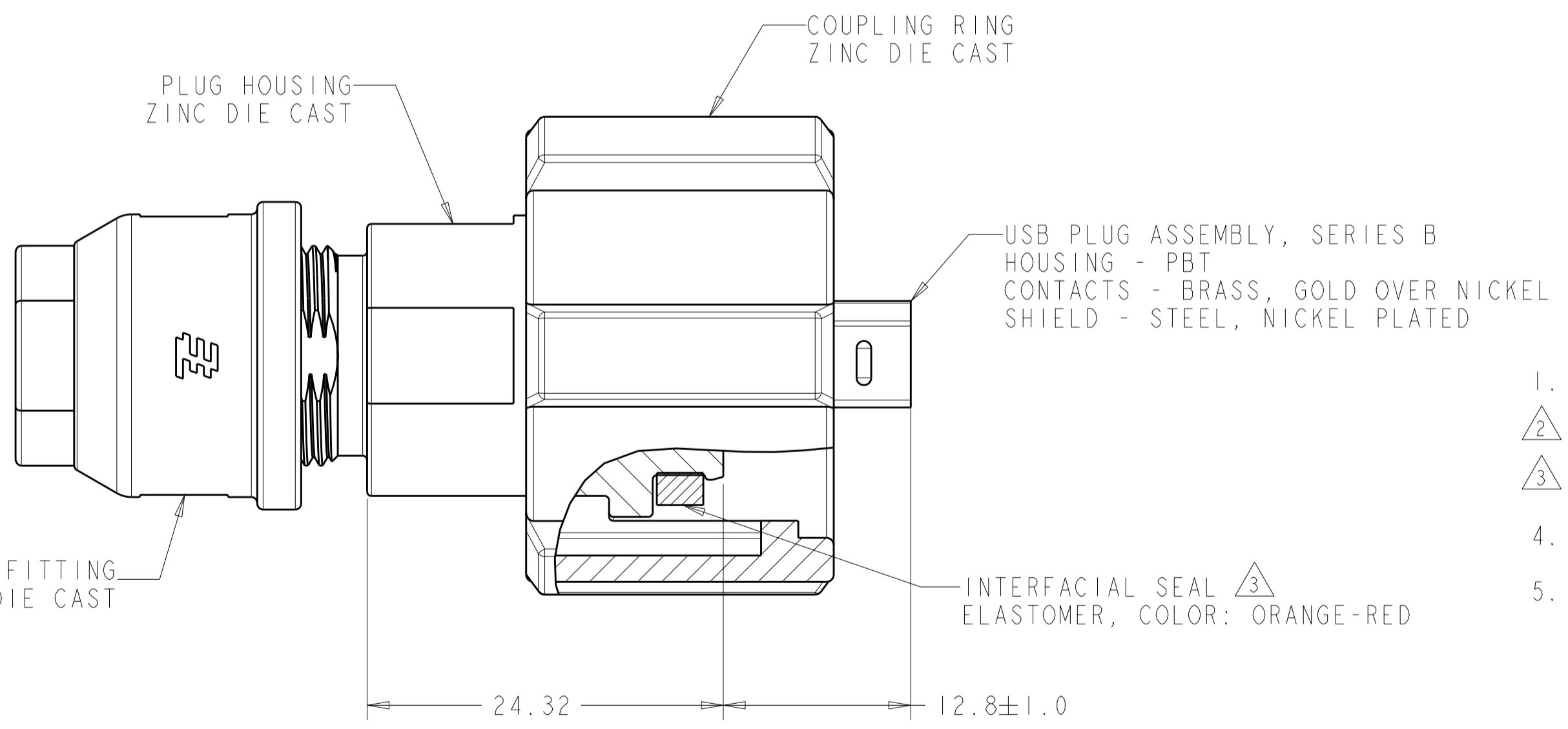

1. CABLE DIAMETER RANGE; Ø 4.5 TO Ø 7.9 mm,
2. 36.9 IN-LBS TORQUE RECOMMENDED FOR DOMENUT.
3. INTERFACIAL SEAL IS SECURED TO HOUSING WITH ADHESIVE.
4. PARTS PACKAGED UNASSEMBLED IN POLYBAG.
5. PACKAGE KITS IN A TE 12120 BOX; MAXIMUM BOX WEIGH SHALL NOT EXCEED 35 POUNDS. USE BUBBLE WRAP ON THE BOTTOM BEFORE FILLING AND ON THE TOP TO FILL THE SPACE IN THE BOX.

2058363-1
PART NUMBER

THIS DRAWING IS A CONTROLLED DOCUMENT FOR TYCO ELECTRONICS CORPORATION. IT IS SUBJECT TO CHANGE AND THE CONTROLLING ENGINEERING ORGANIZATION SHOULD BE CONTACTED FOR THE LATEST REVISION.		DWN S. WELDON 13MAY2008	Tyco Electronics Harrisburg, PA 17105-3608	
DIMENSIONS: mm		CHK K. DAMODHARAN 13MAY2008	NAME PLUG KIT, METAL SHELL, SERIES B, SEALED, INDUSTRIAL USB CONNECTOR	
TOLERANCES UNLESS OTHERWISE SPECIFIED: 0 PLC ±1 1 PLC ±0.2 2 PLC ±0.10 3 PLC ±0.000 4 PLC ±0.0000 ANGLES ±1° FINISH		APVD K. DAMODHARAN 13MAY2008	PRODUCT SPEC 108-2318	RESTRICTED TO
MATERIAL		APPLICATION SPEC 114-13211	WEIGHT	SIZE A2
		CUSTOMER DRAWING	SCALE 3:1	SHEET 1 OF 1 REV A

单击下面可查看定价，库存，交付和生命周期等信息

[>>TE Connectivity\(泰科\)](#)