

THIS DRAWING IS UNPUBLISHED. RELEASED FOR PUBLICATION 20
 © COPYRIGHT 20 BY - ALL RIGHTS RESERVED.

LOC		DIST		REVISIONS			
P	LTR	DESCRIPTION	DATE	DWN	APVD		
CM	57	P1	REVISED PER ECO-13-006897	22APR2013	DLD	DCS	
		R	ECO-19-0140102	05SEP2018	DS	DS	

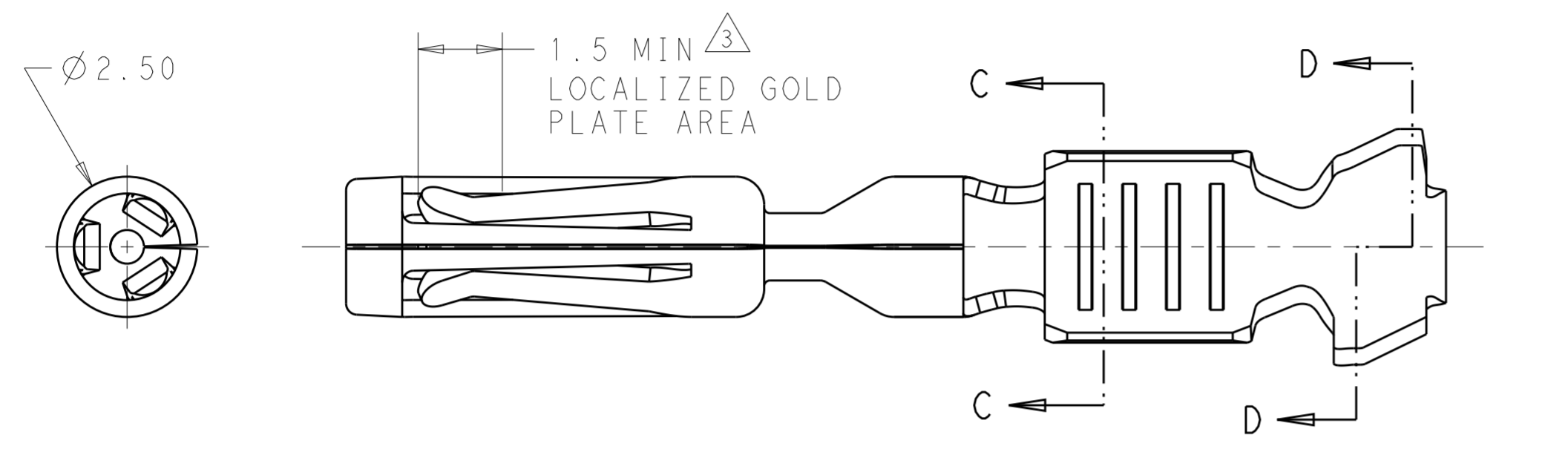

- THE WIRE SIZES QUALIFIED FOR THIS TERMINAL ARE LISTED BELOW SHOWING THE AWG SIZE AND THE METRIC EQUIVALENT
 20AWG - 0.5mm²
 18AWG - 0.8mm²
 16AWG - 1.0mm²

THE TERMINAL HAS ALSO BEEN QUALIFIED TO THE SPECIFIC METRIC WIRE SIZES LISTED BELOW
 1.0mm²FLRY
 1.5mm²FLRY

- INSULATION RANGE: 1.70-2.70.
- 3 .00075 MIN GOLD IN THE LOCALIZED GOLD PLATE AREA, .0025 MIN MATTE TIN IN THE LOCALIZED TIN PLATE AREA OVER .00125 MIN NICKEL OVER ENTIRE CONTACT.
- USED WITH AMPSEAL PLUG ASSEMBLY: 776286, 776273, 770680, 776164
- 5 DIE IDENTIFIER, TE1 AND TE2, LOCATED IN THIS AREA

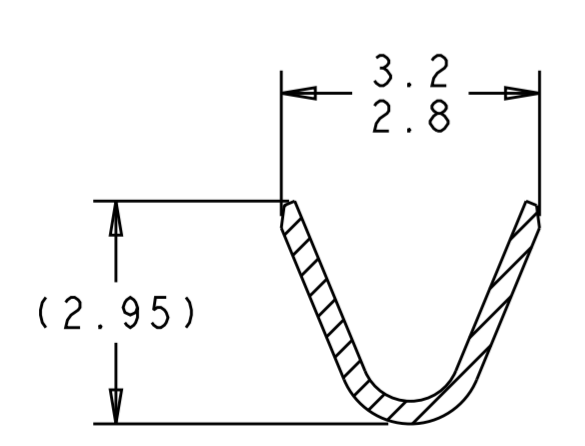
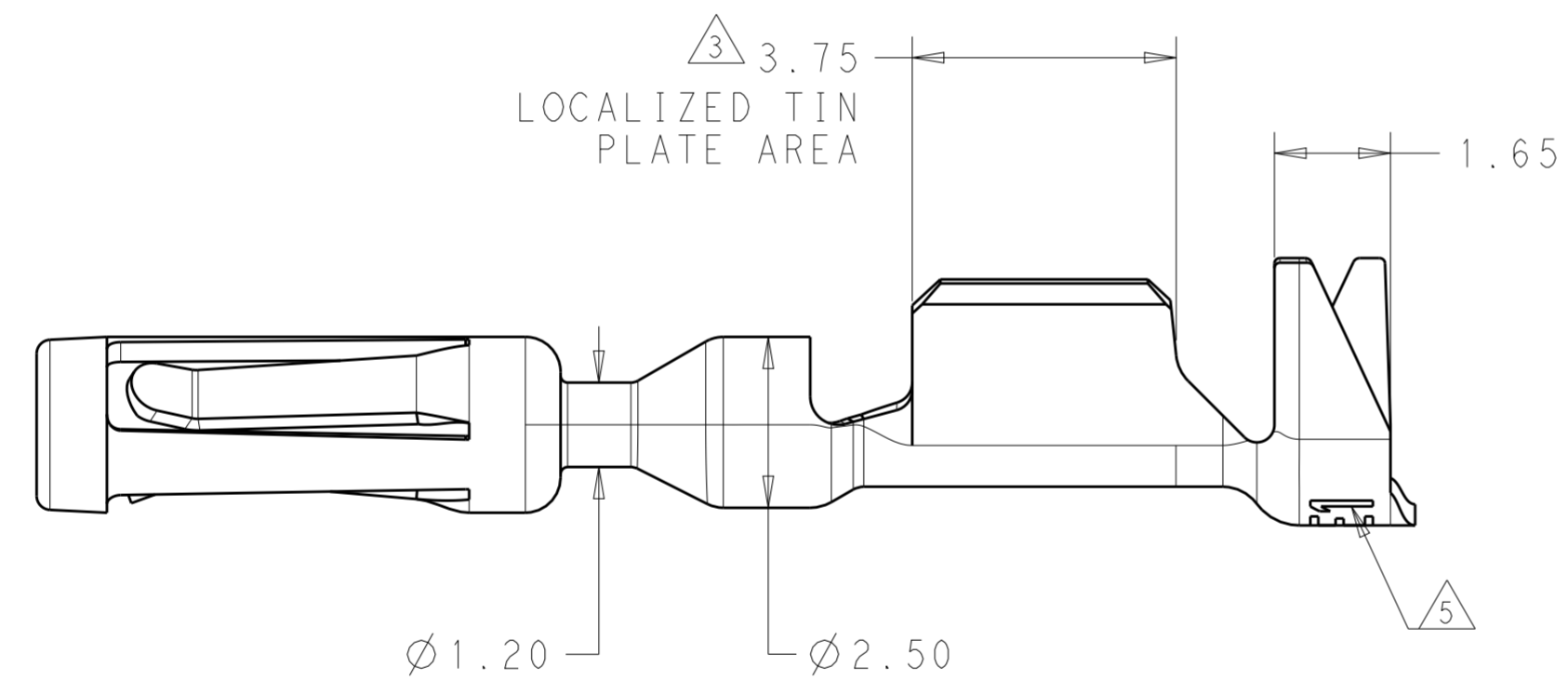

SECTION C-C

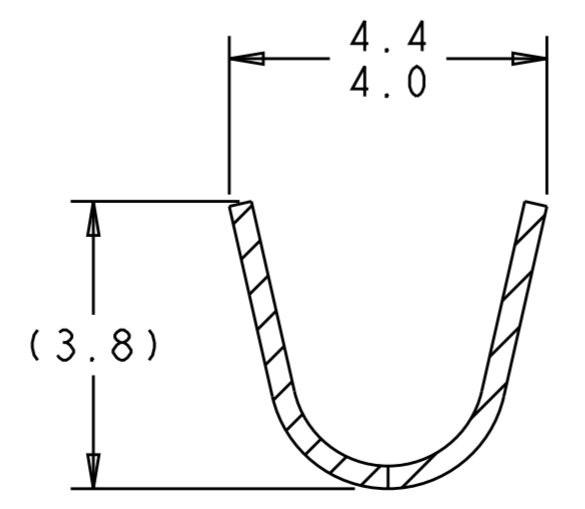

SECTION D-D

MAKE FROM 770520-3	GOLD 3	0.38 COPPER ALLOY	770854-3
MAKE FROM 770520-1	PRE-TIN	0.38 COPPER ALLOY	770854-1
MADE FROM	FINISH	MATERIAL	PART NUMBER

THIS DRAWING IS A CONTROLLED DOCUMENT.		DWN D. DRUMMOND 22APR2013	TE Connectivity	
DIMENSIONS: mm		CHK D. STRAUSSER 22APR2013		
TOLERANCES UNLESS OTHERWISE SPECIFIED:		APVD D. STRAUSSER 22APR2013	NAME CONTACT, AMPSEAL LOOSE PIECE	
0 PLC ±		PRODUCT SPEC	SIZE CAGE CODE DRAWING NO RESTRICTED TO	
1 PLC ±		APPLICATION SPEC	A200779 C-770854	
2 PLC ±0.15		WEIGHT	SCALE 10:1 SHEET 1 OF 1 REV R	
3 PLC ±		MATERIAL		
4 PLC ±		Customer Drawing		
ANGLES ±				
FINISH				
SEE TABLE				

单击下面可查看定价，库存，交付和生命周期等信息

[>>TE Connectivity\(泰科\)](#)