

THIS DRAWING IS UNPUBLISHED. RELEASED FOR PUBLICATION
 © COPYRIGHT - TE Connectivity ALL RIGHTS RESERVED.

REVISIONS					
P	LTR	DESCRIPTION	DATE	DWN	APVD
C		REVISED PER ECO-17-004099	29AUG2017	RS	DR
D		REVISED PER ECO-19-004230	21MAR2019	RS	DR

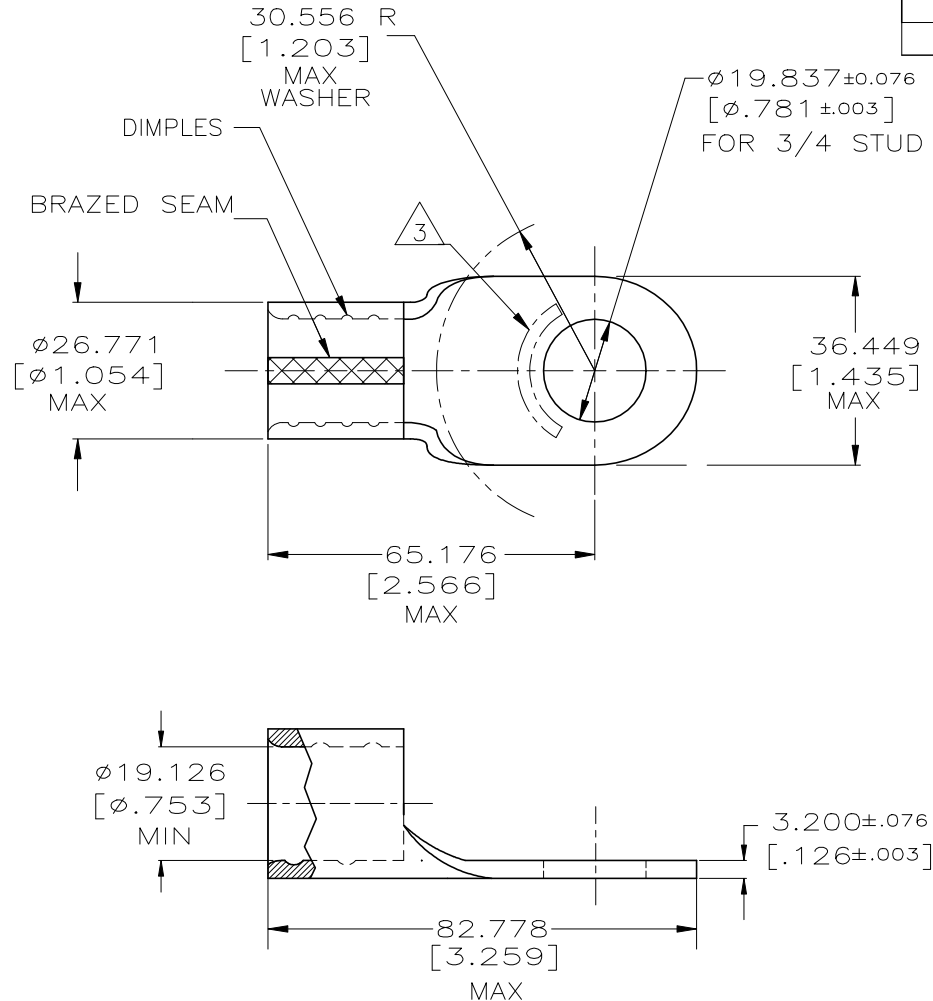

AMP WIRE RANGE	E13288 Listed
250-300 MCM SOLID OR STRANDED	250-300 MCM STRANDED

- 1 MATERIAL: COPPER PER ASTM B152, ANNEALED
- 2 FINISH: TIN PLATE 0.00254 [.000100] MIN EXT THK PER ASTM B545
- 3 STAMP AMP 250-300 MCM* APPROX AS SHOWN

25	LOOSE PIECE	323140
QTY	PACKAGE TYPE	PART NUMBER

AMP INCORPORATED CUSTOMER SERVICE SYSTEMS		MAX RECOMMENDED OPERATING TEMPERATURE: 170° C [338° F] MAX
FOR ADDITIONAL PRODUCT INFORMATION OR COPIES OF DRAWINGS AND TECHNICAL DOCUMENTS	PRODUCT INFORMATION CENTER 1-800-522-6752	VOLTAGE RATING: NOT APPLICABLE
FOR APPLICATION TOOLING INFORMATION	TOOLING ASSISTANCE CENTER 1-800-722-1111	WIRE CROSS SECTIONAL AREA RANGE: 127.0-152.0mm ² [231,000-300,000] CIR MILS SOLID OR STRANDED
FOR ORDER ENTRY	1-800-526-5142	THIS DRAWING IS A CONTROLLED DOCUMENT FOR AMP INCORPORATED. IT IS SUBJECT TO CHANGE, AND THE CONTROLLING ENGINEERING ORGANIZATION SHOULD BE CONTACTED FOR THE LATEST REVISION.

THIS DRAWING IS A CONTROLLED DOCUMENT.		DWN DK SCHRUM 6/12/92
DIMENSIONS: mm [INCHES]		CHK RD HEIM 6/26/92
TOLERANCES UNLESS OTHERWISE SPECIFIED:		APVD AJ KAUFMAN 6/26/92
0 PLC ± -		PRODUCT SPEC UL 486A-B
1 PLC ± -		APPLICATION SPEC -
2 PLC ± -		WEIGHT -
3 PLC ± 0.203[.008]		MATERIAL 1
4 PLC ± -		FINISH 2
ANGLES ± -		CUSTOMER DRAWING

TE Connectivity		
NAME TERMINAL, RING TONGUE, SOLISTRAND™ WIRE SIZE: 250-300 MCM		
SIZE A3	CAGE CODE 00779	DRAWING NO G=323140
RESTRICTED TO -	SCALE 1:1	SHEET 1 OF 1
REV D		

单击下面可查看定价，库存，交付和生命周期等信息

[>>TE Connectivity\(泰科\)](#)