

THIS DRAWING IS UNPUBLISHED. RELEASED FOR PUBLICATION  
 © COPYRIGHT BY TYCO ELECTRONICS CORPORATION. ALL INTERNATIONAL RIGHTS RESERVED.

LOC	DIST	REVISIONS					
G	14	P	LTR	DESCRIPTION	DATE	DWN	APVD
		F1		REVISED PER ECO-11-002228	11FEB11	HMR	DR

<b>AMP</b> WIRE RANGE	<b>RU</b> FILE E13288	<b>LR7189</b> Certified
4 AWG STRANDED	4 AWG STRANDED	4 AWG STRANDED

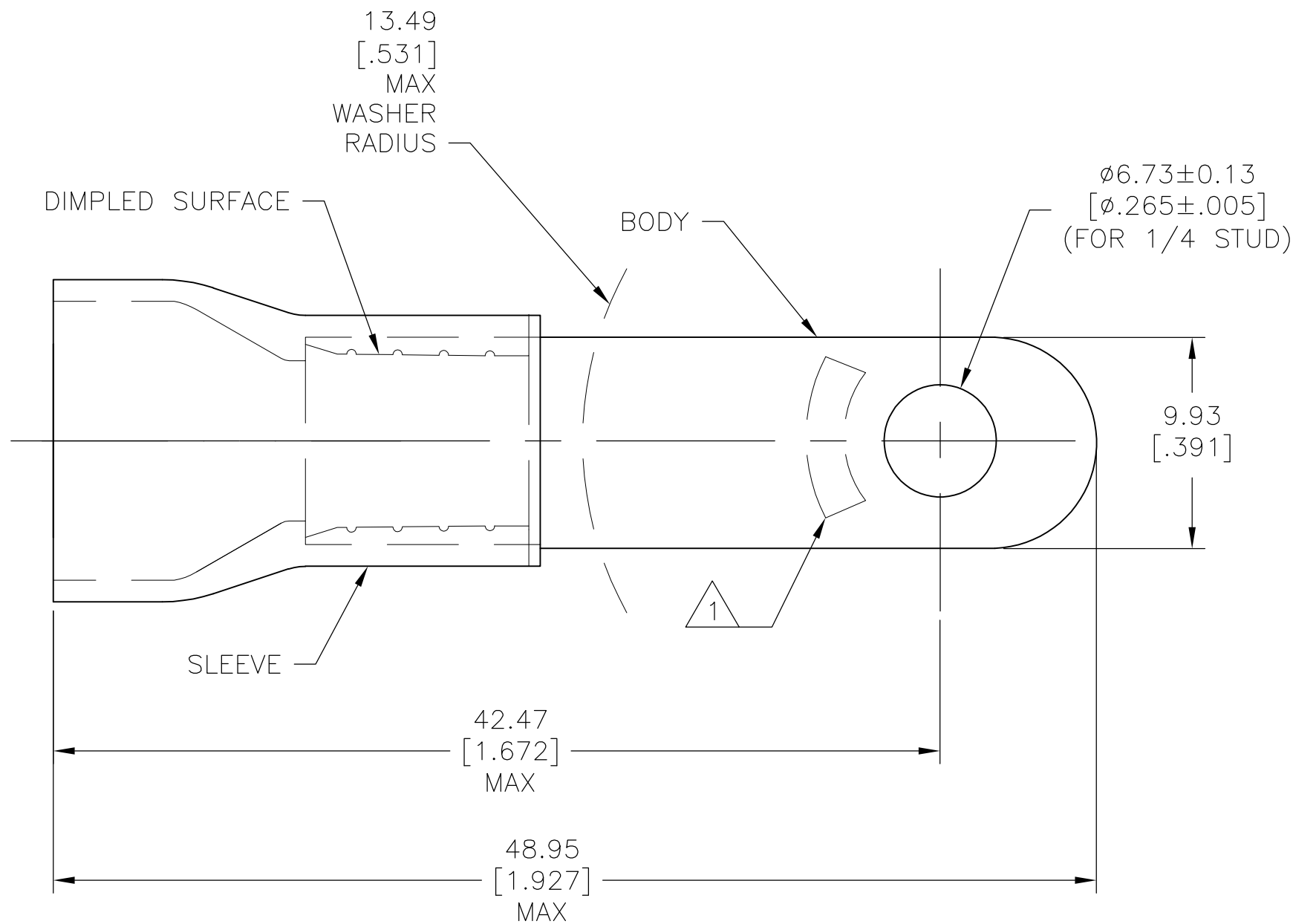

- 1 STAMP AMP 4\* LOCATE APPROX AS SHOWN
- 2 TONGUE MATERIAL THK 1.22 ± 0.08 [.048 ± .003]
- 3 WIRE INSULATION DIA 11.43 [.450] MAX
- 4 TAPE ITEMS ARE ON 30.48 [1.200] CENTERS

500	ON TAPE	55680-2
100	LOOSE PIECE	55680-1
QTY	PACKAGE TYPE	PART NO

<b>AMP INCORPORATED CUSTOMER SERVICE SYSTEM</b>		MAX RECOMMENDED OPERATING TEMPERATURE: 105°C	THIS DRAWING IS A CONTROLLED DOCUMENT.		DWN S.S. GOULDEN 10-12-93	<b>Tyco Electronics</b> Tyco Electronics Corporation Harrisburg, PA 17105-3608			
FOR ADDITIONAL PRODUCT INFORMATION OR COPIES OF DRAWINGS AND TECHNICAL DOCUMENTS	PRODUCT INFORMATION CENTER 1-800-522-6752	VOLTAGE RATING: 600 V MAX	DIMENSIONS: mm [INCHES]	TOLERANCES UNLESS OTHERWISE SPECIFIED:	CHK R. HERSEY 10-12-93	NAME TERMINAL, RING TONGUE, PLASTI-GRIP™, WIRE SIZE: 4 AWG			
FOR APPLICATION TOOLING INFORMATION	TOOLING ASSISTANCE CENTER 1-800-722-1111	CIRCULAR MIL AREA: 16.77mm-26.65mm² [33,100-52,600] STRANDED		0 PLC ± - 1 PLC ± - 2 PLC ± 0.20 [.008] 3 PLC ± - 4 PLC ± - ANGLES ± -	APVD B.BARE 10-12-93	PRODUCT SPEC NOT AVAILABLE			
FOR ORDER ENTRY	1-800-526-5142	MATERIAL COPPER PER ASTM B-152 PVC, COLOR YELLOW		FINISH TIN PLATE PER ASTM-B545	APPLICATION SPEC 114-2161	SIZE A3	CAGE CODE 00779	DRAWING NO C-55680	RESTRICTED TO -
CUSTOMER DRAWING					WEIGHT -	SCALE 4:1	SHEET 1 OF 1	REV F1	

单击下面可查看定价，库存，交付和生命周期等信息

[>>TE Connectivity\(泰科\)](#)