

THIS DRAWING IS UNPUBLISHED. RELEASED FOR PUBLICATION
 © COPYRIGHT BY TYCO ELECTRONICS CORPORATION. ALL INTERNATIONAL RIGHTS RESERVED.

LOC	DIST	REVISIONS			
P	LTR	DESCRIPTION	DATE	DWN	APVD
G	14	D1	REV PER ECR 09-026553	08DEC09	JR TM

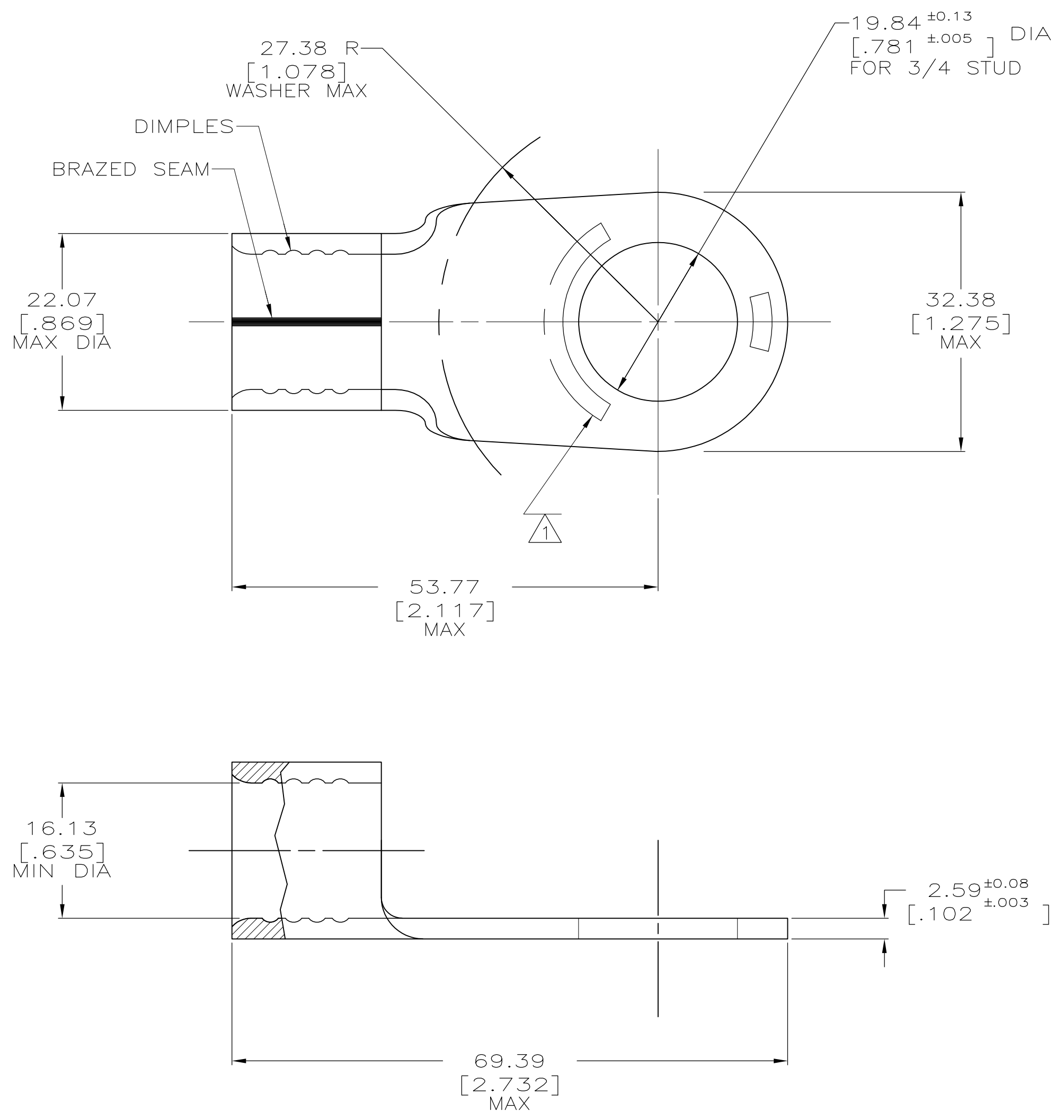

AMP WIRE RANGE	E13288 Listed
4/0 AWG SOLID OR STRANDED	4/0 AWG STRANDED
LR7189 Certified	MILITARY P/N AND CLASS
4/0 AWG SOLID OR STRANDED	MS20659-160 CLASS 2

- 1 STAMP AMP 4/0W* 200 APPROX AS SHOWN
- 2 COPPER PER ASTM B-152, ANNEALED
- 3 TIN PLATE 0.00254 [.000100] MIN PER ASTM B-545
- 4 MAX RECOMMENDED OPERATING TEMP 170°C
- 5 WIRE CROSS SECTIONAL AREA RANGE:
96.3-117.0mm² [190,000-231,000] CIR MILS
STRANDED OR SOLID

322228
PART NO.

THIS DRAWING IS A CONTROLLED DOCUMENT.		DWN DK SCHRUM 10/5/93	Tyco Electronics Corporation Harrisburg, PA 17105-3608	
DIMENSIONS: MM [INCHES]		CHK AJ KAUFMAN 10/6/93	NAME JL MECKLEY	
TOLERANCES UNLESS OTHERWISE SPECIFIED:		APVD 10/6/93	PRODUCT SPEC	
0 PLC ± -		APPLICATION SPEC		
1 PLC ± -		WEIGHT		
2 PLC ± 0.20[.008]		SIZE A2		
3 PLC ± -		CAGE CODE 00779		
4 PLC ± -		DRAWING NO C=322228		
ANGLES ± -		RESTRICTED TO		
FINISH		SCALE 2:1		
- 2		SHEET 1 of 1		
- 3		REV D1		
MATERIAL		CUSTOMER DRAWING		

单击下面可查看定价，库存，交付和生命周期等信息

[>>TE Connectivity\(泰科\)](#)