



ULTIMATE-PRECISION DIGITAL LBB

SPECIFICATIONS

- ✦ High precision, 0.1% of reading or 1µm
- ✦ EMI and ESD protected (CE certified)
- ✦ Spring actuated probes
- ✦ Robust cast aluminum case (electronics)
- ✦ Stackable with T-Connectors for networking
- ✦ T-Connector available separately
- ✦ USB interface available (with COM libraries)
- ✦ Up to 31 devices on USB with external power
- ✦ External power supply available

The **Ultimate-Precision Digital LBB** system consists of DLBB digital probes (or gage heads) daisy chained in a network, using T-Connectors (available separately) with DE-9 connectors. Each DLBB includes a highly repeatable analog AC LVDT (Linear Variable Differential Transformer) probe guided with a precision linear ball bearing, mated to an in-line digital I/O signal conditioning module. The circuitry and firmware feature digital calibration and linearity correction of the digital output position signal with extremely high accuracy.

The DLBB probes operate in conjunction with our available USB interface module. Our robust dimensional gaging probes are engineered to provide highly precise and repeatable measurements in various industrial, quality assurance and metrology applications.

The system is based on an RS-485 half duplex, multi-drop network providing plug-and-play functionality. The DLBB probes convert their position signal into digital data which is then transmitted by the RS-485 network using asynchronous transmission (poll/response). The devices support both standard and buffered modes. Our USB 2.0 full speed compliant interface module connects to this network (using a T-Connector) to communicate with and allow data transfer to a computer. When our USB module is plugged into a computer running a WINDOWS® operating system, the Device Manager (in the section "Universal Serial Bus Controllers") of the Computer Management Console displays the name "Meas-Spec Digital LBB Serial Converter", clearly identifying our DLBB device amongst others.

The available DLBB external power supply is capable of supplying 31 DLBB gaging probes (2 Amps). It features an integral T-Connector which is permanently attached to it. This special T-Connector will interrupt the bus power and switch it over to the external power supply, for all Digital LBB gaging probes connected downstream.

FEATURES

- ✦ High resolution 14-bit digitizing module
- ✦ Built-in digital linearity correction
- ✦ Robust probes with precision linear ball bearing
- ✦ Very easy to setup and use, plug-and-play
- ✦ USB bus or externally powered (both available)
- ✦ USB device name for easy WINDOWS® recognition
- ✦ Up to 31 probes on one network (external power)
- ✦ RoHS compliant and CE certified

APPLICATIONS

- ✦ Wobble/run-out of rotating parts (i.e. rotors, axles)
- ✦ Free-form measurements (i.e. airfoils, windshields, crankshafts, camshafts)
- ✦ Factory automated inspection systems (i.e. engine pistons, bearings, etc.)
- ✦ Optics Inspection Systems (i.e. mirrors, lenses)
- ✦ SPC data collection
- ✦ Metrology

SPECIFICATIONS

Parameter	Specification	Comment
Measurement ranges	1, 2, and 5 mm	
Accuracy	0.1% of reading or 1µm	Whichever is greater
Repeatability	0.0065% of range or 0.15µm	Whichever is greater
Calibration temperature	72 ± 7°F [22 ± 4°C]	
Resolution	14 bits	
Supply voltage	5.00 ± 0.25 Volts DC	
Supply current	60mA maximum	
Operating temperature	32 to 140°F [0 to 60°C]	
Storage temperature	-4 to +158°F [-20 to +70°C]	Dry air environment
Maximum operating relative humidity	60%	Non-condensing
Standard and Buffered mode sampling rate	240 readings per second	
Buffer size	3000 Samples	
Bus format	8 Bits, 1 Stop, Odd Parity	
Bus baud rate	187.5KBd	Standard & buffered modes
Bus protocol	Proprietary device addressable	
Bus interface	RS-485	
Max number of DLBB probes on USB	4 (on computer USB bus power)	Plus USB interface module
	31 (on external power)	USB powered by computer USB
Cable length	2 meters	
Cable jacket material	Polyurethane	
Housing material, electronics	Aluminum, epoxy powder coated	
Weight (device without T-Connector)	115 grams	
Weight of T-Connector	50 grams	Available separately
Weight of USB interface	115 grams	Available separately
External power supply output current	2 Amps	Available separately

DRAWINGS AND DIMENSIONS

DIGITAL LBB GAGING PROBE

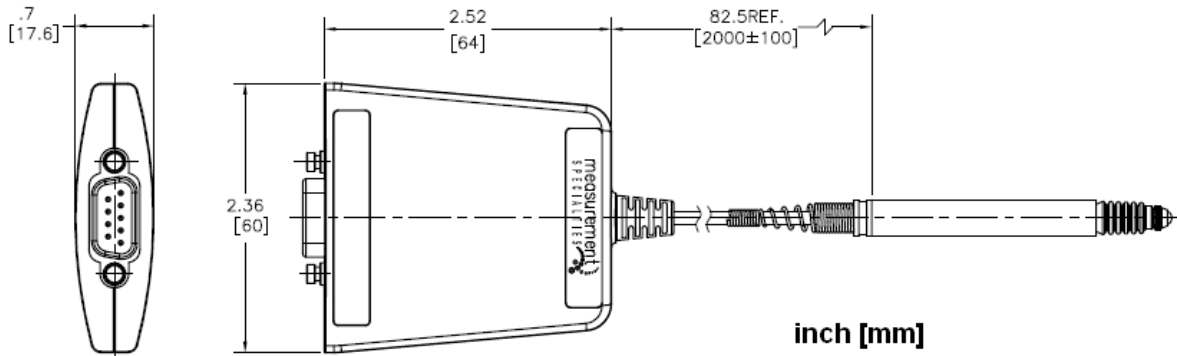

T-CONNECTOR

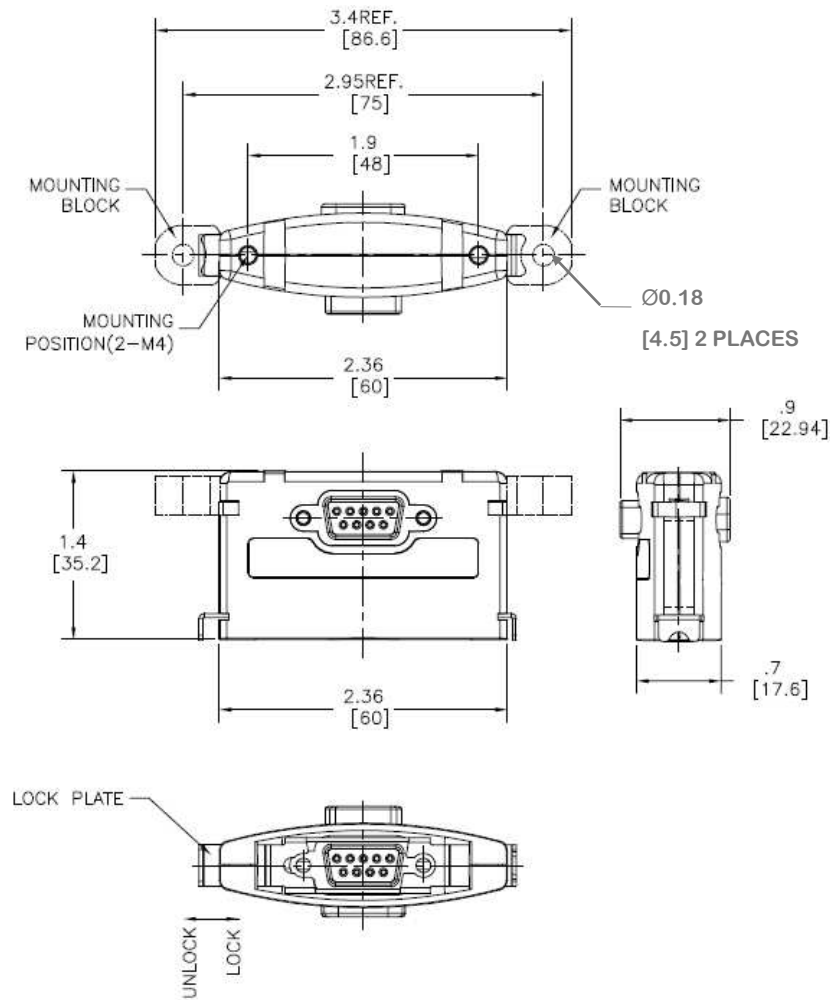

POWER SUPPLY KIT (3 COMPONENTS)

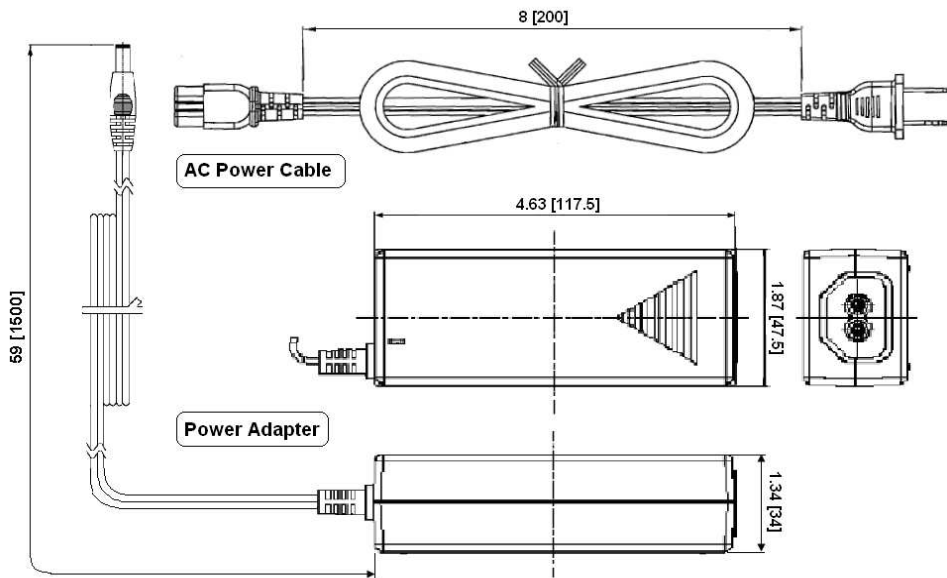
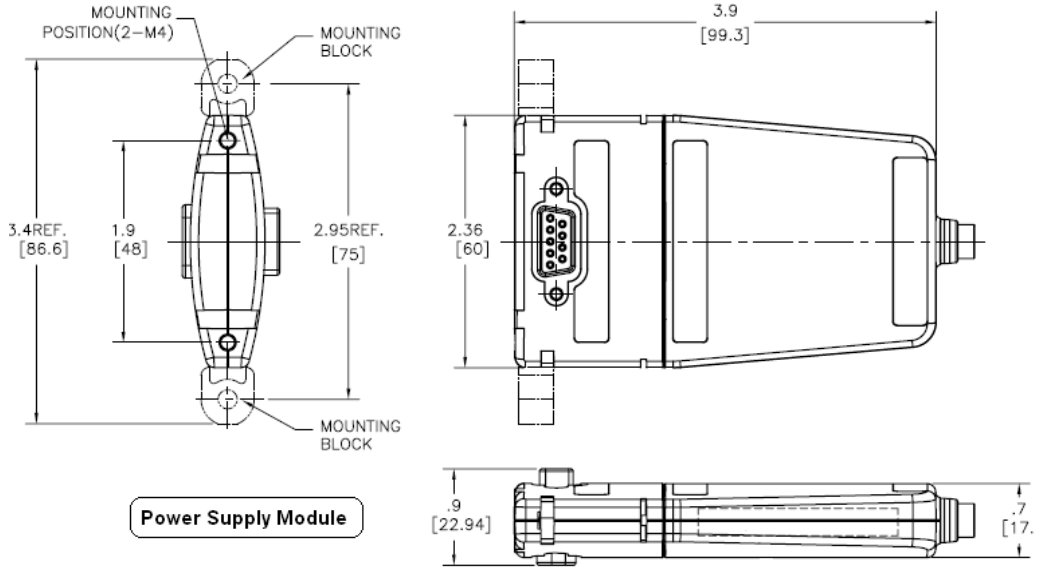

USB INTERFACE MODULE

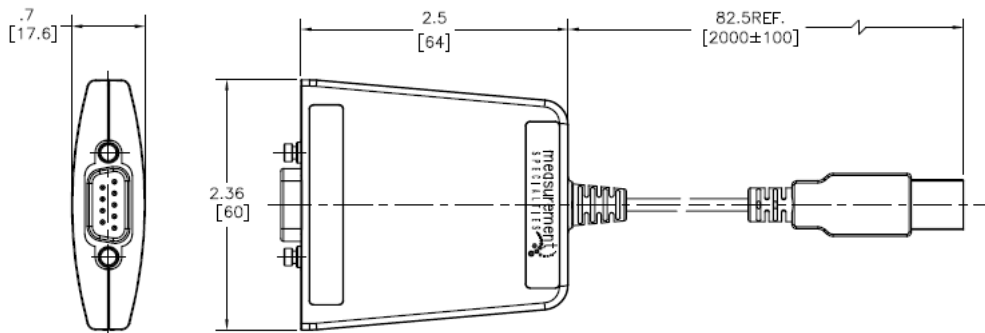

ORDERING INFORMATION

Description	Probe or sleeve dia.	Actuation	Model	Part Number
1mm range probe	8mm	Spring	DLBB315PA-020	72350009-000
2mm range probe	8mm	Spring	DLBB315PA-040	72350012-000
5mm range probe	8mm	Spring	DLBB315PA-100	72350015-000
USB interface module for DLBB			DLBB USB INTERFACE	72290002-000
T-Connector for DLBB			DLBB T-CON	72290003-000
Power supply kit for DLBB (100-240VAC, 50/60Hz input; 5VDC, 2A out)			DLBB USB POWER SUPPLY	72290004-000

NORTH AMERICA

Measurement Specialties, Inc.,
 a TE Connectivity company
 Tel: 800-522-6752
 Email: customercare.frm@te.com

EUROPE

Measurement Specialties (Europe), Ltd.,
 a TE Connectivity Company
 Tel: 800-440-5100
 Email: customercare.bevx@te.com

ASIA

Measurement Specialties (China) Ltd.,
 a TE Connectivity company
 Tel: 0400-820-6015
 Email: customercare.shzn@te.com

TE.com/sensorsolutions

Measurement Specialties, Inc., a TE Connectivity company.

Measurement Specialties, TE Connectivity, TE Connectivity (logo) and EVERY CONNECTION COUNTS are trademarks. All other logos, products and/or company names referred to herein might be trademarks of their respective owners.

The information given herein, including drawings, illustrations and schematics which are intended for illustration purposes only, is believed to be reliable. However, TE Connectivity makes no warranties as to its accuracy or completeness and disclaims any liability in connection with its use. TE Connectivity's obligations shall only be as set forth in TE Connectivity's Standard Terms and Conditions of Sale for this product and in no case will TE Connectivity be liable for any incidental, indirect or consequential damages arising out of the sale, resale, use or misuse of the product. Users of TE Connectivity products should make their own evaluation to determine the suitability of each such product for the specific application.

© 2015 TE Connectivity Ltd. family of companies All Rights Reserved.

单击下面可查看定价，库存，交付和生命周期等信息

[>>TE Connectivity\(泰科\)](#)