

P	LTR	DESCRIPTION	DATE	DWN	APVD
A		RELEASE TO PRODUCTION	28NOV2019	AY	PS
A1		REMOVE POSITION 4, 6 AND 8	04JUN2020	AY	PS

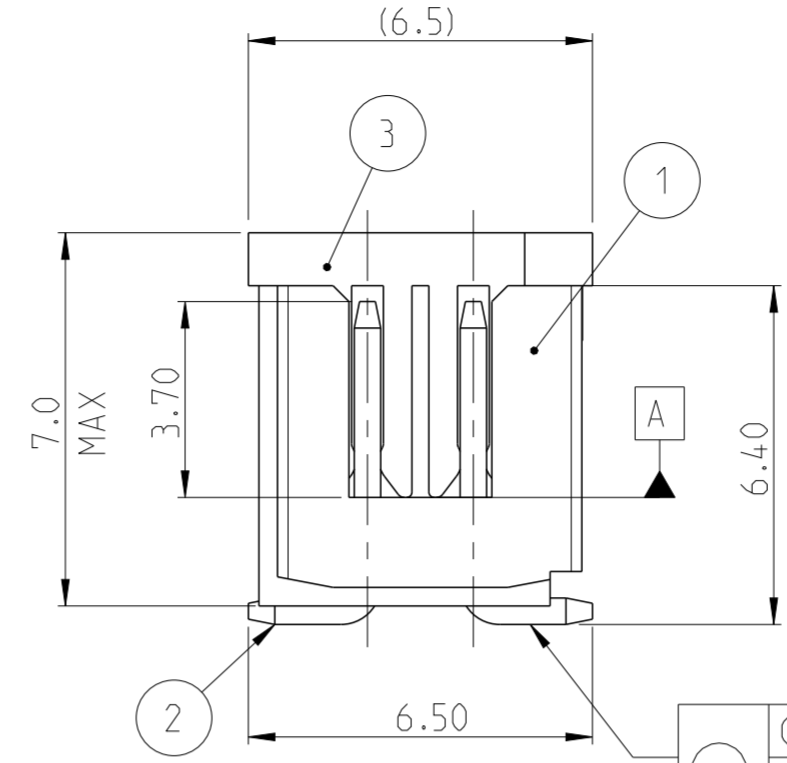
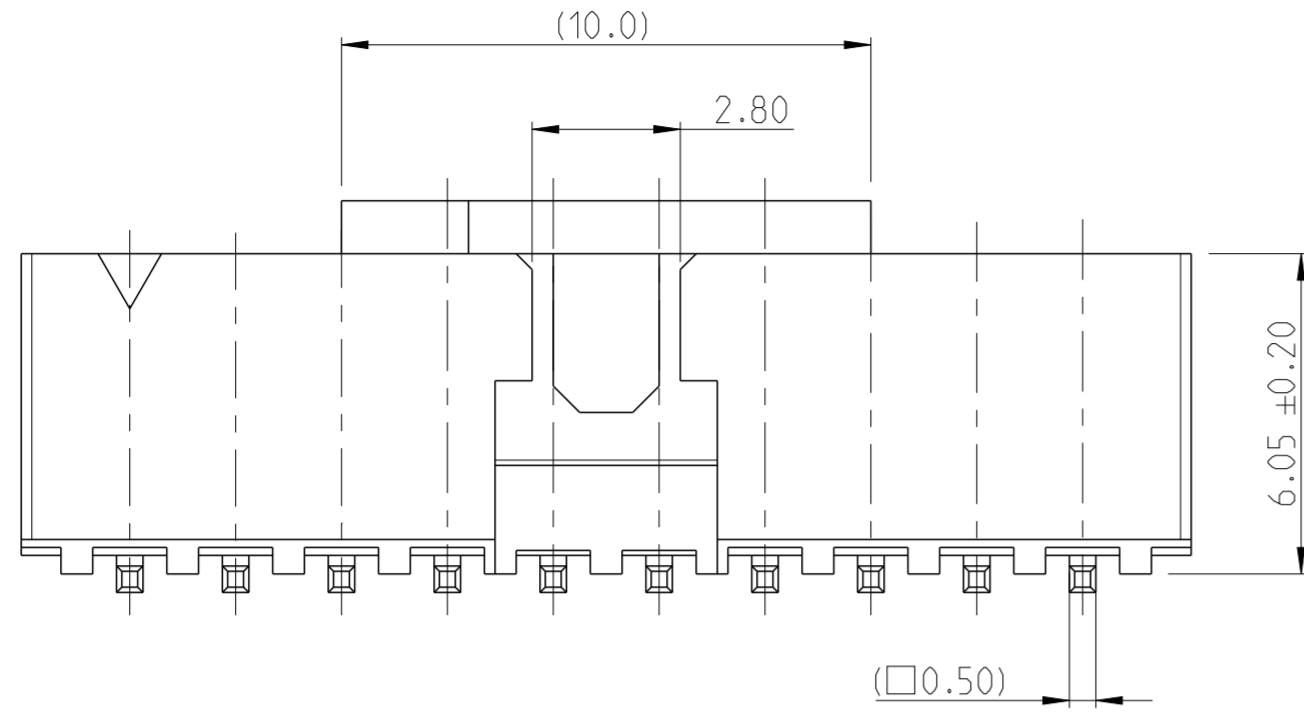

NOTES:
 1. MATERIAL
 HOUSING & P&P CAP : HIGH TEMPERATURE THERMOPLASTIC, UL94-V0; COLOR- BLACK
 POST : COPPER ALLOY
 FINISH :
 MATING SIDE: MIN. 0.1 μm GOLD OVER NICKEL UNDER PLATING.
 SOLDER SIDE: MIN. 2.0 μm TIN OVER NICKEL UNDER PLATING.
 2. PACKAGING: TUBE (WITH PICK AND PLACE CAP)
 3 TOLERANCE NOT CUMULATIVE.

	0.10	A	10-30 POS
	0.15	A	32-50 POS

ALL CONTACTS

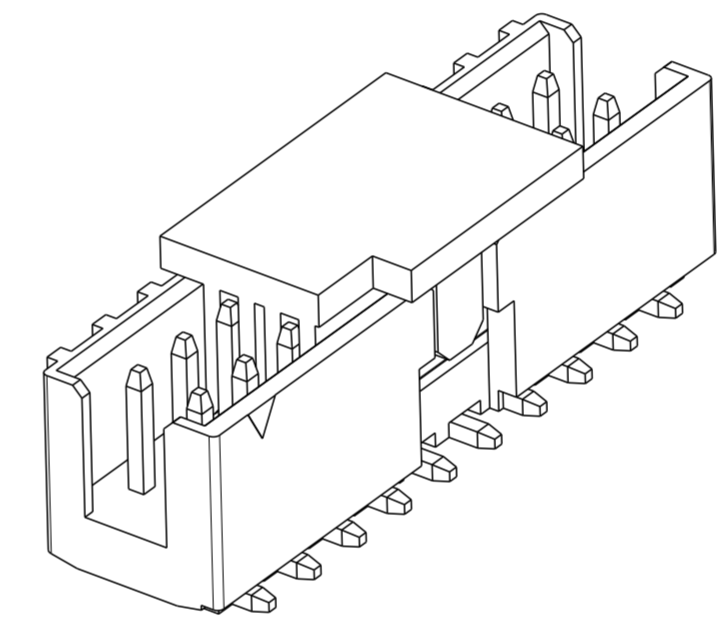
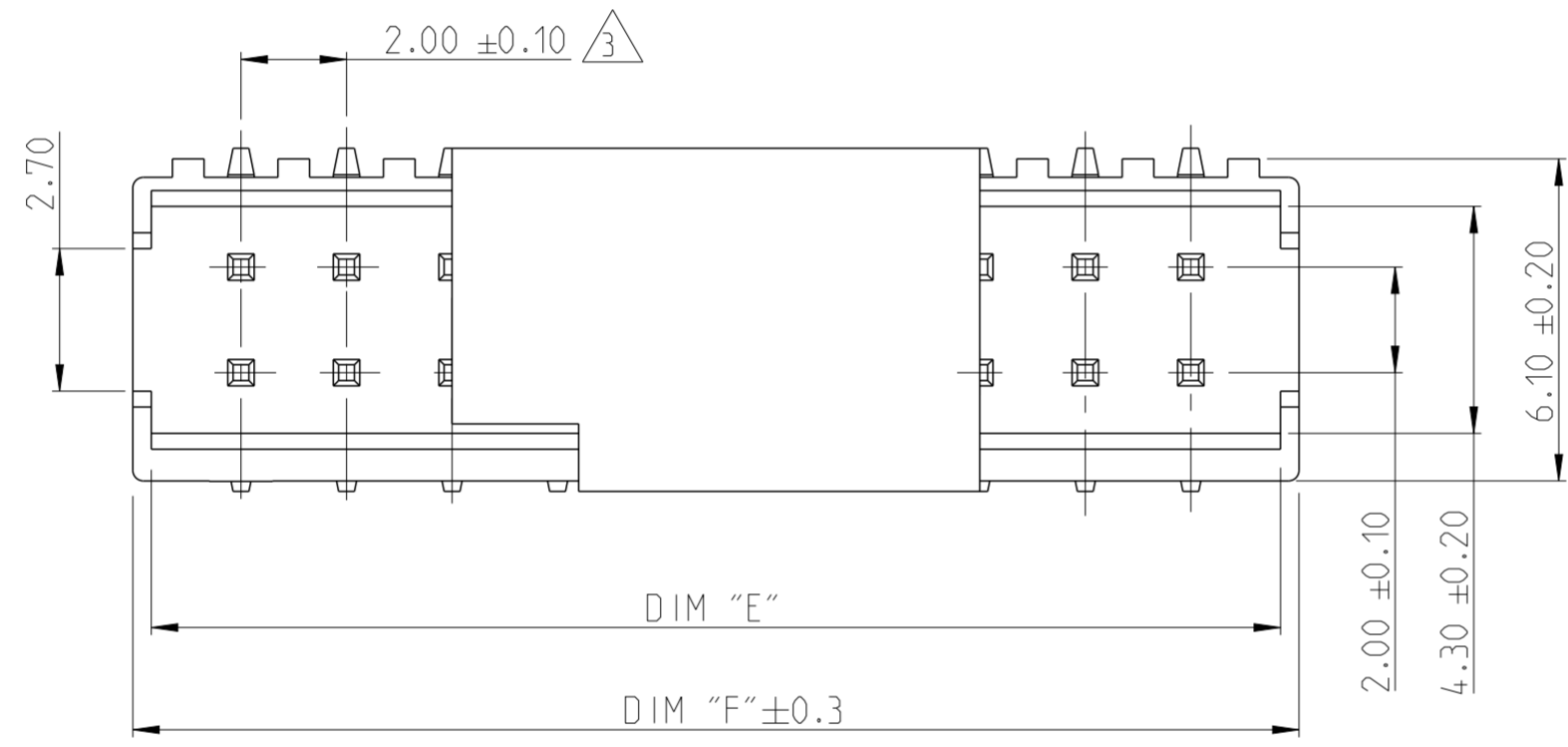

2-2842274-0 AS SHOWN

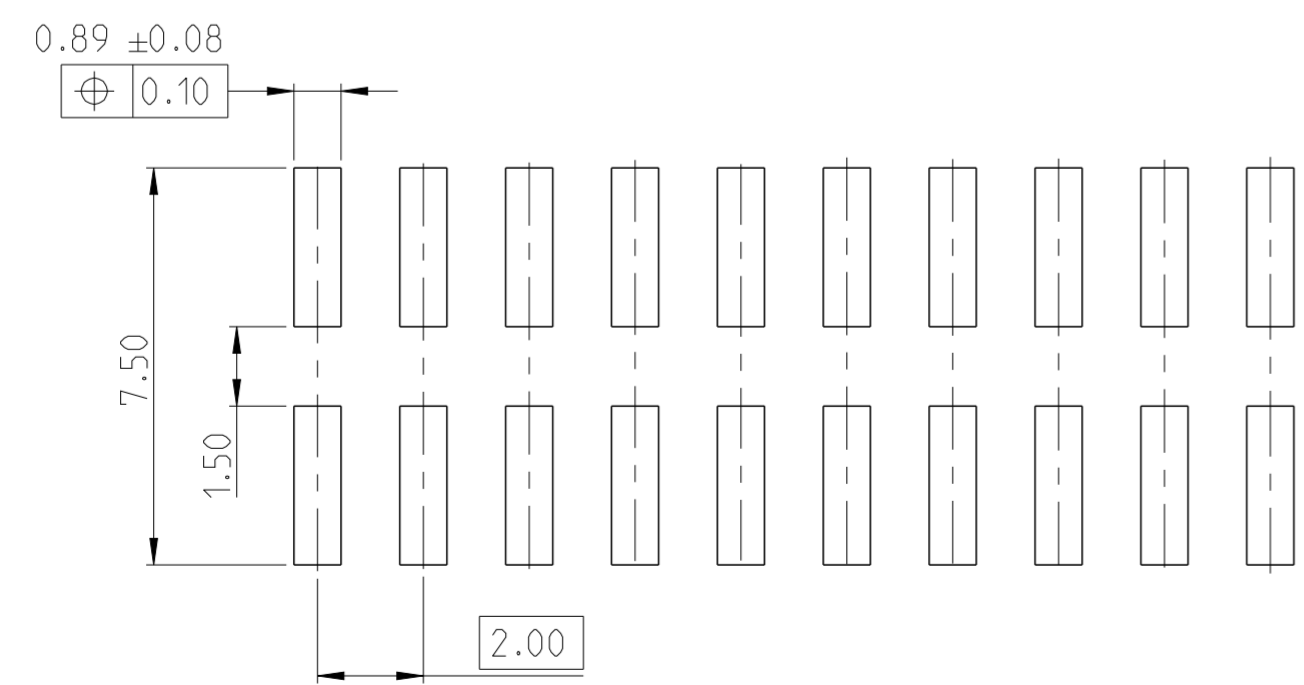

RECOMMENDED PCB PATTERN

52.10	51.40	50	5-2842274-0
50.10	49.40	48	4-2842274-8
48.10	47.40	46	4-2842274-6
46.10	45.40	44	4-2842274-4
44.10	43.40	42	4-2842274-2
42.10	41.40	40	4-2842274-0
40.10	39.40	38	3-2842274-8
38.10	37.40	36	3-2842274-6
36.10	35.40	34	3-2842274-4
34.10	33.40	32	3-2842274-2
32.10	31.40	30	3-2842274-0
30.10	29.40	28	2-2842274-8
28.10	27.40	26	2-2842274-6
26.10	25.40	24	2-2842274-4
24.10	23.40	22	2-2842274-2
22.10	21.40	20	2-2842274-0
20.10	19.40	18	1-2842274-8
18.10	17.40	16	1-2842274-6
16.10	15.40	14	1-2842274-4
14.10	13.40	12	1-2842274-2
12.10	11.40	10	1-2842274-0
DIM "F"	DIM "E"	POS.	TE PN.

PICK AND PLACE CAP	3
CONTACT PIN	2
HOUSING	1
DESCRIPTION	ITEM NO.

THIS DRAWING IS A CONTROLLED DOCUMENT.		DWN 11NOV2019 ANKIT YADAV
DIMENSIONS: mm		CHK 25NOV2019 KARTHIK JK
TOLERANCES UNLESS OTHERWISE SPECIFIED:		APVD 27NOV2019 PRASHANTH S.
0 PLC ±	1 PLC ±	PRODUCT SPEC 108-64040
2 PLC ±0.25	3 PLC ±	APPLICATION SPEC 114-32259
4 PLC ±	ANGLES ±2°	WEIGHT -
MATERIAL FINISH SEE NOTES	SEE NOTES	CUSTOMER DRAWING

TE Connectivity		NAME	
		AMPMODU 2mm SHROUDED HEADER DUAL ROW, VERTICAL SMD, 0.1 Au, TUBE, WITH PICK AND PLACE CAP	
SIZE	CAGE CODE	DRAWING NO	RESTRICTED TO
A2	00779	©-2842274	-
SCALE 5:1		SHEET 1 OF 1	REV A1

单击下面可查看定价，库存，交付和生命周期等信息

[>>TE Connectivity\(泰科\)](#)