

THIS DRAWING IS UNPUBLISHED. RELEASED FOR PUBLICATION
 © COPYRIGHT BY TYCO ELECTRONICS CORPORATION. ALL RIGHTS RESERVED.

LOC	DIST	REVISIONS					
FT	0	P	LTR	DESCRIPTION	DATE	DWN	APVD
		C		REVISED PER ECO-07-010208	5/1/07	SS	SH

NOTES:
 ① TUBING: POLYOLEFIN, 94V2 RATED.
 SLEEVE: NYLON, BLACK.
 ② ACTUAL SHAPE MAY VARY DUE TO PROCESS VARIANCE.

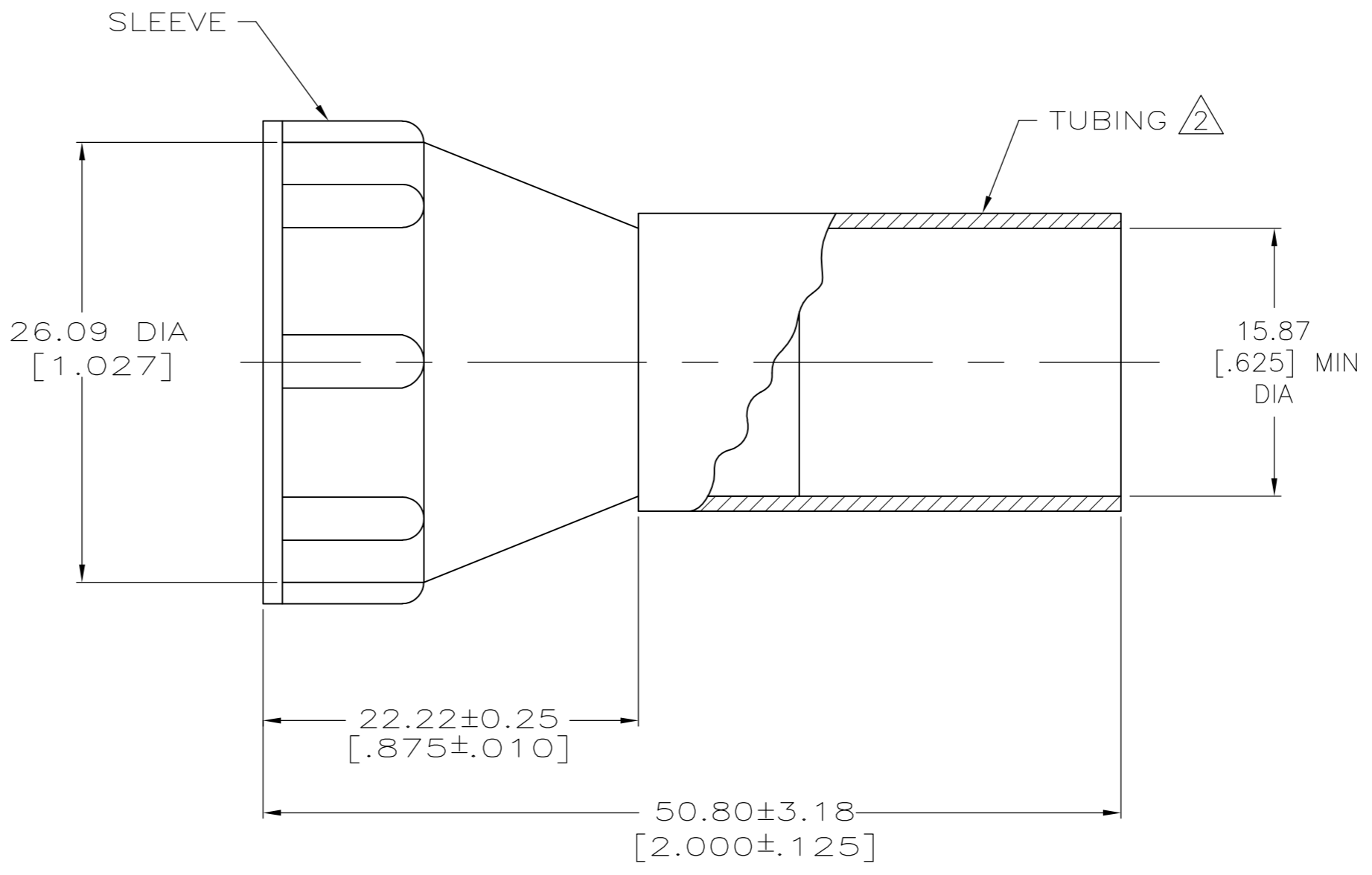
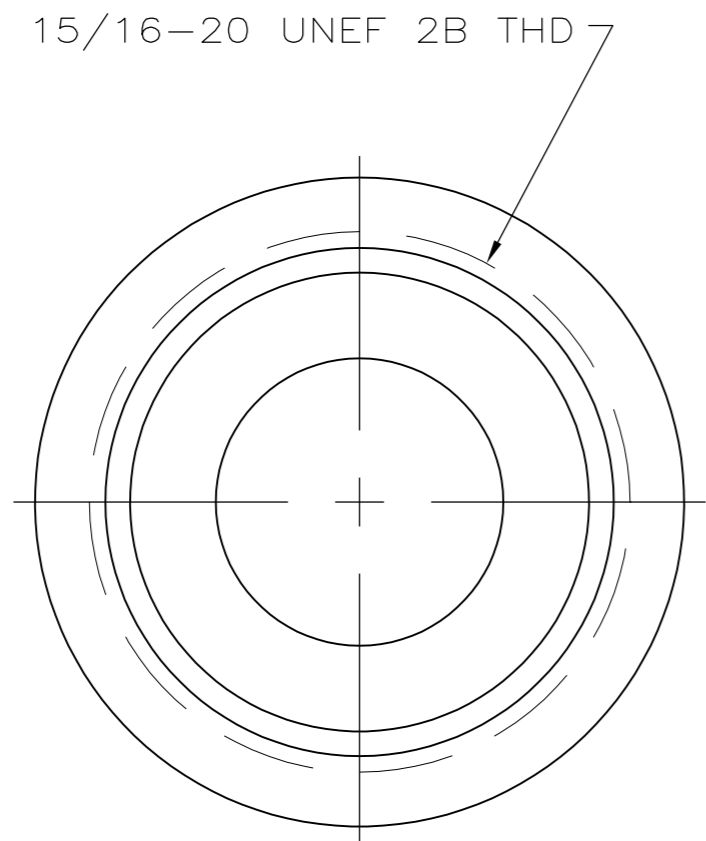

THIS DRAWING IS A CONTROLLED DOCUMENT.		DWN	W.G.LENKER	19 MAR 96	 Tyco Electronics Corporation Harrisburg, PA 17105-3608
DIMENSIONS: mm [INCHES]		CHK	R.STONE	19 MAR 96	
TOLERANCES UNLESS OTHERWISE SPECIFIED:		APVD	A.FRANTUM	20 MAR 96	
0 PLC ± - 1 PLC ± - 2 PLC ± 0.13[.005] 3 PLC ± - 4 PLC ± - ANGLES ± -		PRODUCT SPEC	NAME		
MATERIAL - ①		FINISH	-		STRAIN RELIEF ASSEMBLY, SHELL SIZE 17, CPC
-		WEIGHT	-		SIZE
-		CUSTOMER DRAWING	SCALE	NTS	CAGE CODE
-					A2 00779
-					DRAWING NO
-					C=213933
-					RESTRICTED TO
-					-
-					SHEET
-					1 OF 1
-					REV
-					C

213933

单击下面可查看定价，库存，交付和生命周期等信息

[>>TE Connectivity\(泰科\)](#)