

REVISIONS					
P.	LTN	DESCRIPTION	DATE	DWN	APVD
A		RELEASED PER ECO-19-007456	15MAY2019	CJV	JW
B		REVISED PER ECO-19-011736	06AUG2019	AP	JW

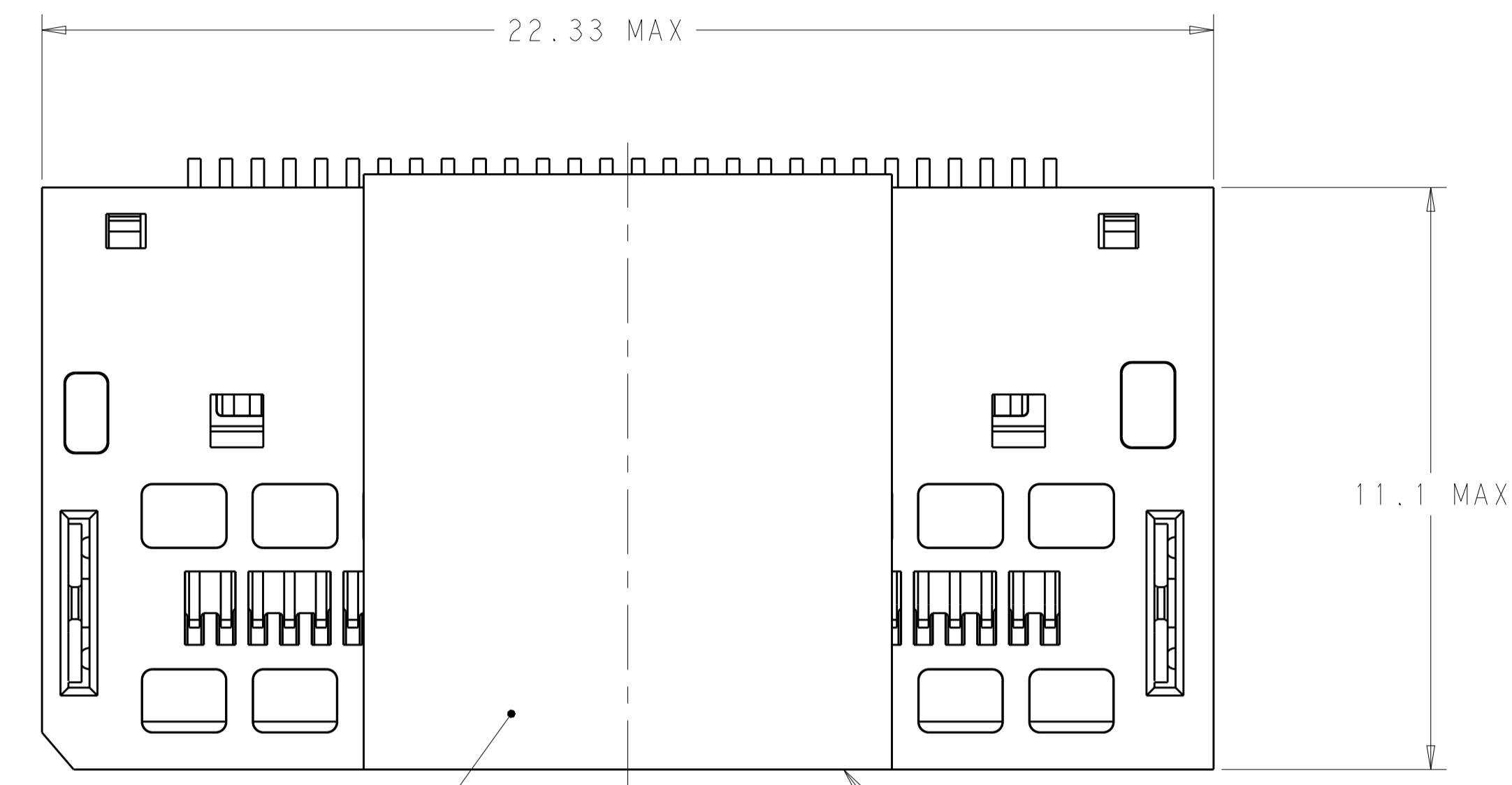

- △ HOUSING, ORGANIZER, CONTACT OVERMOLDS - LCP, UL94-V0, BLACK. CONTACTS AND HOLD DOWNS - COPPER ALLOY. PICK AND PLACE TAPE - POLYIMIDE FILM.
- △ CONTACTS - GOLD PLATE ON MATING SURFACES, TIN PLATE ON SOLDER FEET. HOLD DOWNS - TIN PLATE.
- △ DATUMS AND BASIC DIMENSIONS ESTABLISHED BY CUSTOMER.
- 4. MINIMUM HOST PCB THICKNESS: 1.5.
- △ SEE MSA SPECIFICATION FOR ADDITIONAL PADDLE CARD LAYOUTS COMPATIBLE WITH THIS RECEPTACLE AND FOR OPTIONAL SPLIT CONTACT PAD LAYOUTS FOR THE PADDLE CARD. SPECIFICATION PINOUT MAY ALSO DESIGNATE PAD SEQUENCE DIFFERENT FROM ILLUSTRATION.
- △ POSITIONS DESIGNATED AS "SIGNAL" ARE REQUIRED LOCATIONS FOR HIGH SPEED DIFFERENTIAL PAIR SIGNALING. THESE LOCATIONS MAY ALSO BE USED FOR SUPPORTING SIDEBAND SIGNALS OR OTHER UTILITY PURPOSES. POSITIONS DESIGNATED AS "GROUND" ARE REQUIRED WHEN SUPPORTING HIGH SPEED DIFFERENTIAL SIGNALS. THESE LOCATIONS MAY ALSO BE USED FOR SIDEBAND SIGNALS OR OTHER UTILITY PURPOSES.
- △ COMPONENT AND TRACE KEEP OUT AREA. EACH EDGE 0.15 MIN FROM EDGE OF HOLE.
- △ TAPE AND REEL PACKAGED FOR PICK AND PLACE SMT PROCESSING, SEE FIGURE 1. POCKET TAPE: WIDTH = 44.

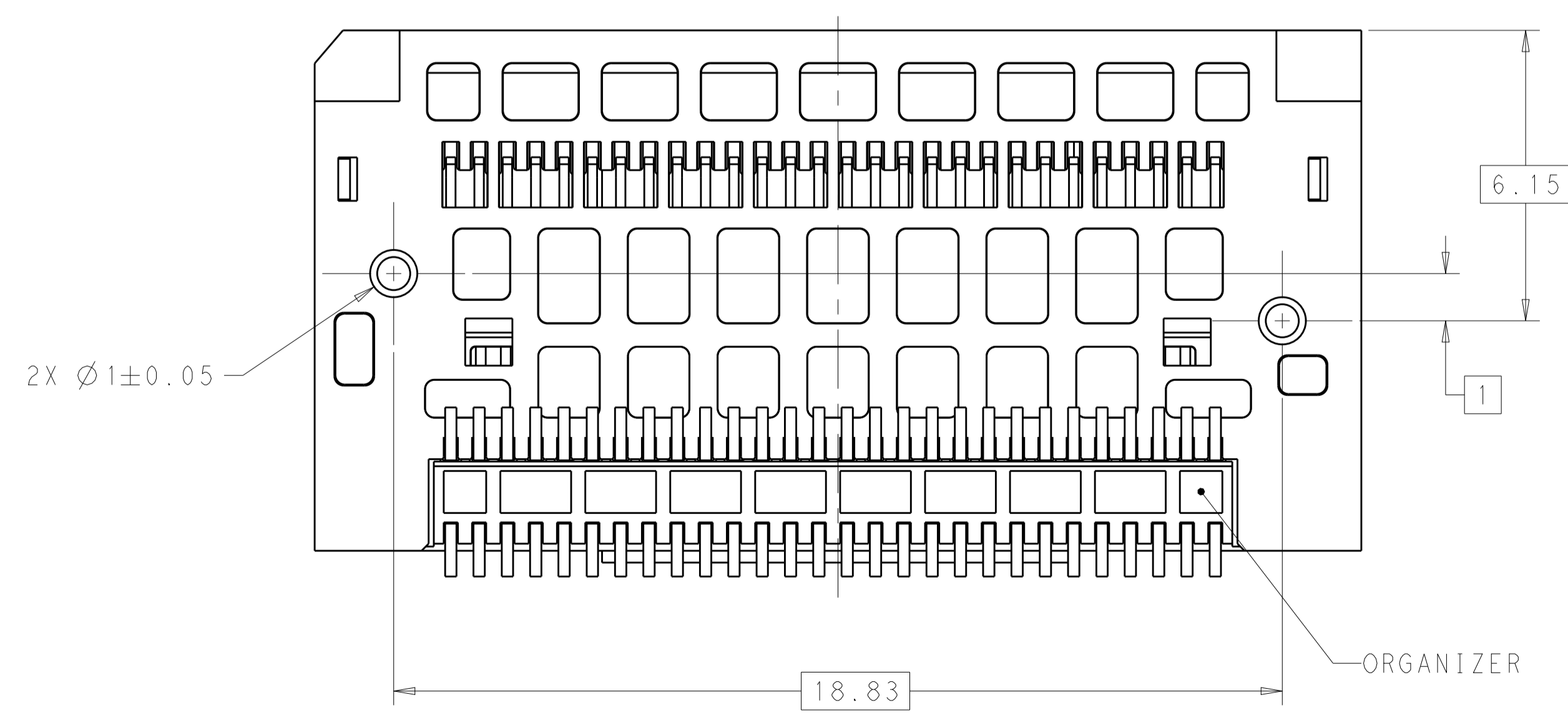
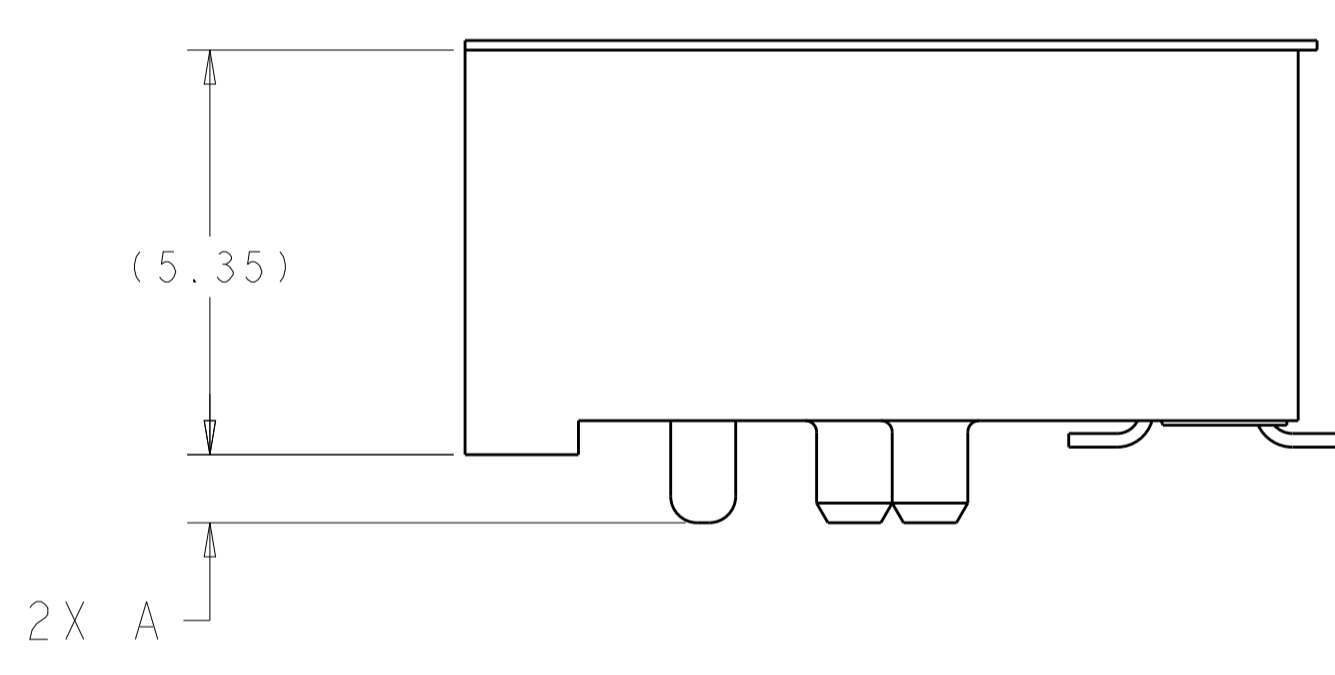
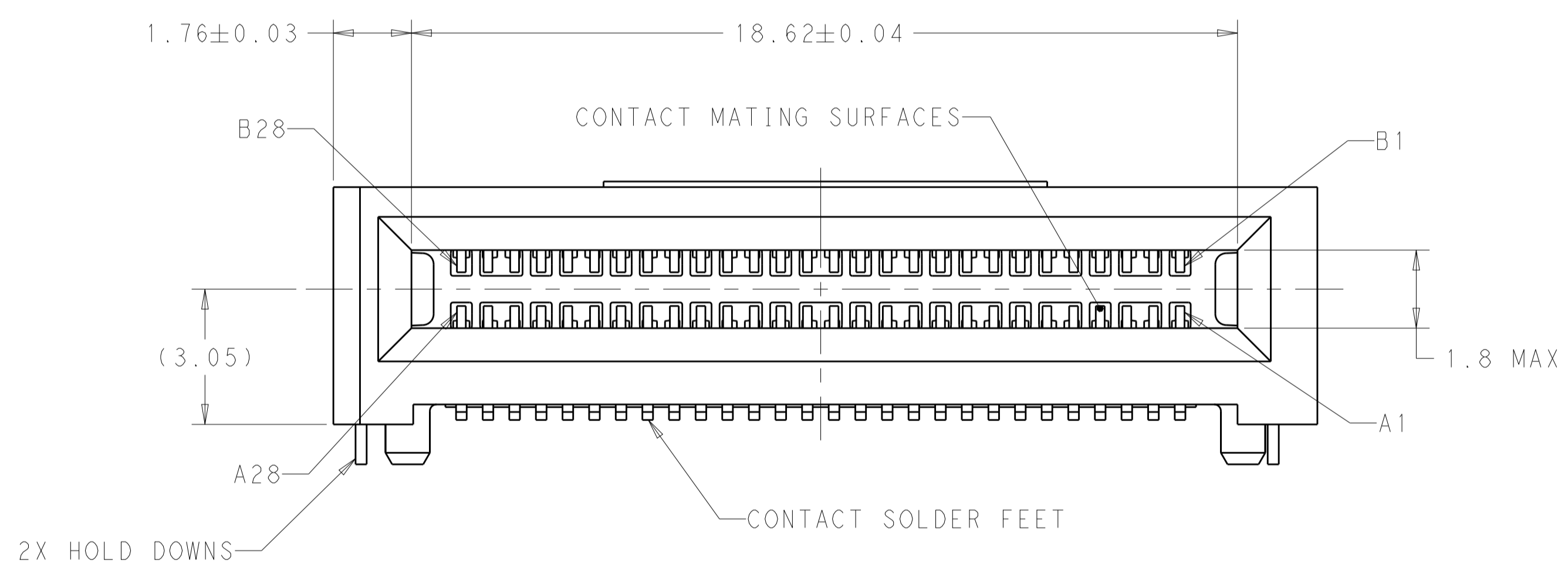

0.9±0.1	0.76µm Au	24	400	NO	200	1-2327672-3
	0.38µm Au				100	1-2327672-2
	FLASH Au/PdNi				50	1-2327672-1
	0.76µm Au				200	2327672-3
	0.38µm Au				100	2327672-2
A	FLASH Au/PdNi	20	500	YES	50	2327672-1
	PLATING	POCKET TAPE PITCH	REEL QUANTITY	PICK AND PLACE TAPE	MATING CYCLES	PART NUMBER

THIS DRAWING IS A CONTROLLED DOCUMENT.

DIMENSIONS: mm

TOLERANCES UNLESS OTHERWISE SPECIFIED:

0 PLC	±
1 PLC	±
2 PLC	±
3 PLC	±
4 PLC	±
ANGLES	±

MATERIAL: △ FINISH: △

CUSTOMER DRAWING

OWN: M. SHIRK 22FEB2018  
 CHK: D. HARMON 22FEB2018  
 APVD: D. HARMON 22FEB2018

NAME: RECEPTACLE ASSEMBLY, RIGHT ANGLE, 56 POSITION, SLIVER 2.0

SIZE: A1 CAGE CODE: 100779 DRAWING NO: 2327672

SCALE: 10:1 SHEET: 1 OF 4 REV: B



REVISIONS				
P.	LTN.	DESCRIPTION	DATE	APVD.
-	-	SEE SHEET 1	-	-

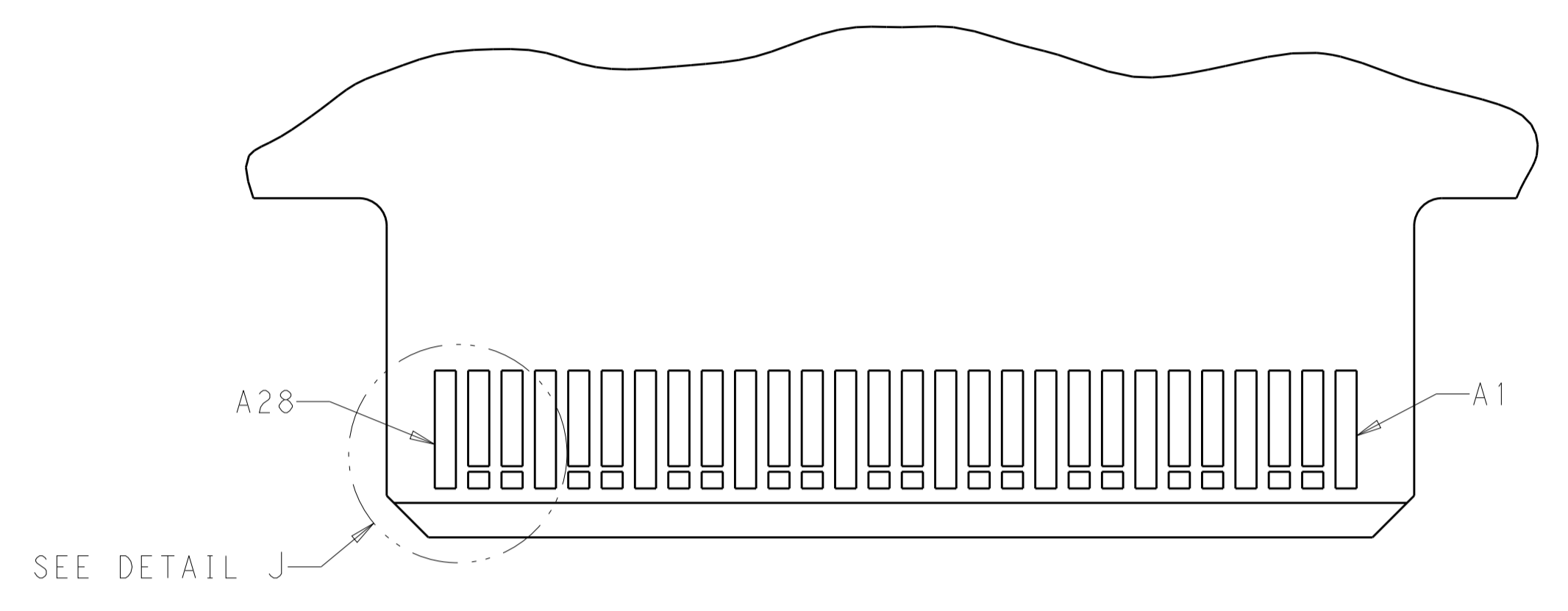
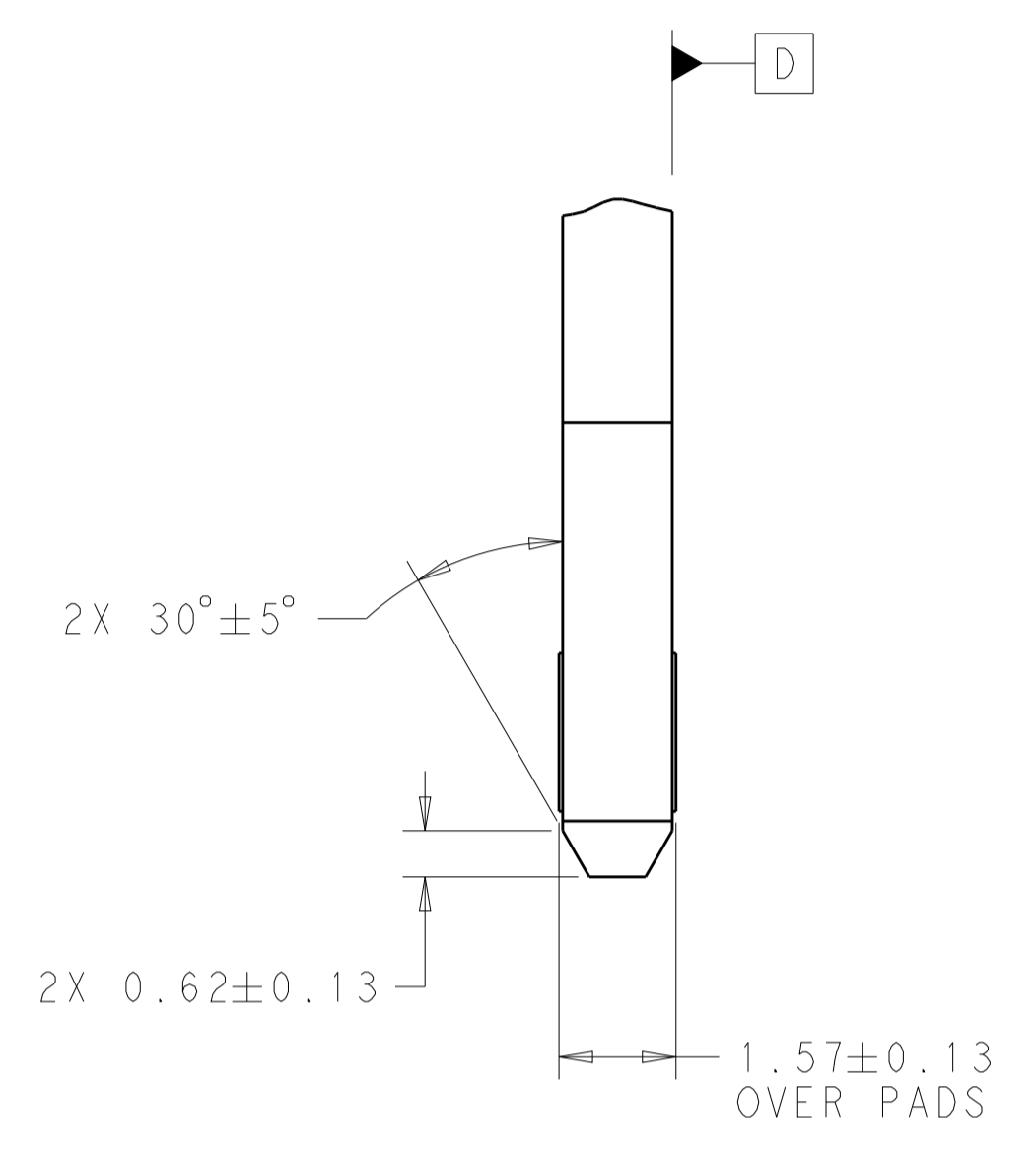
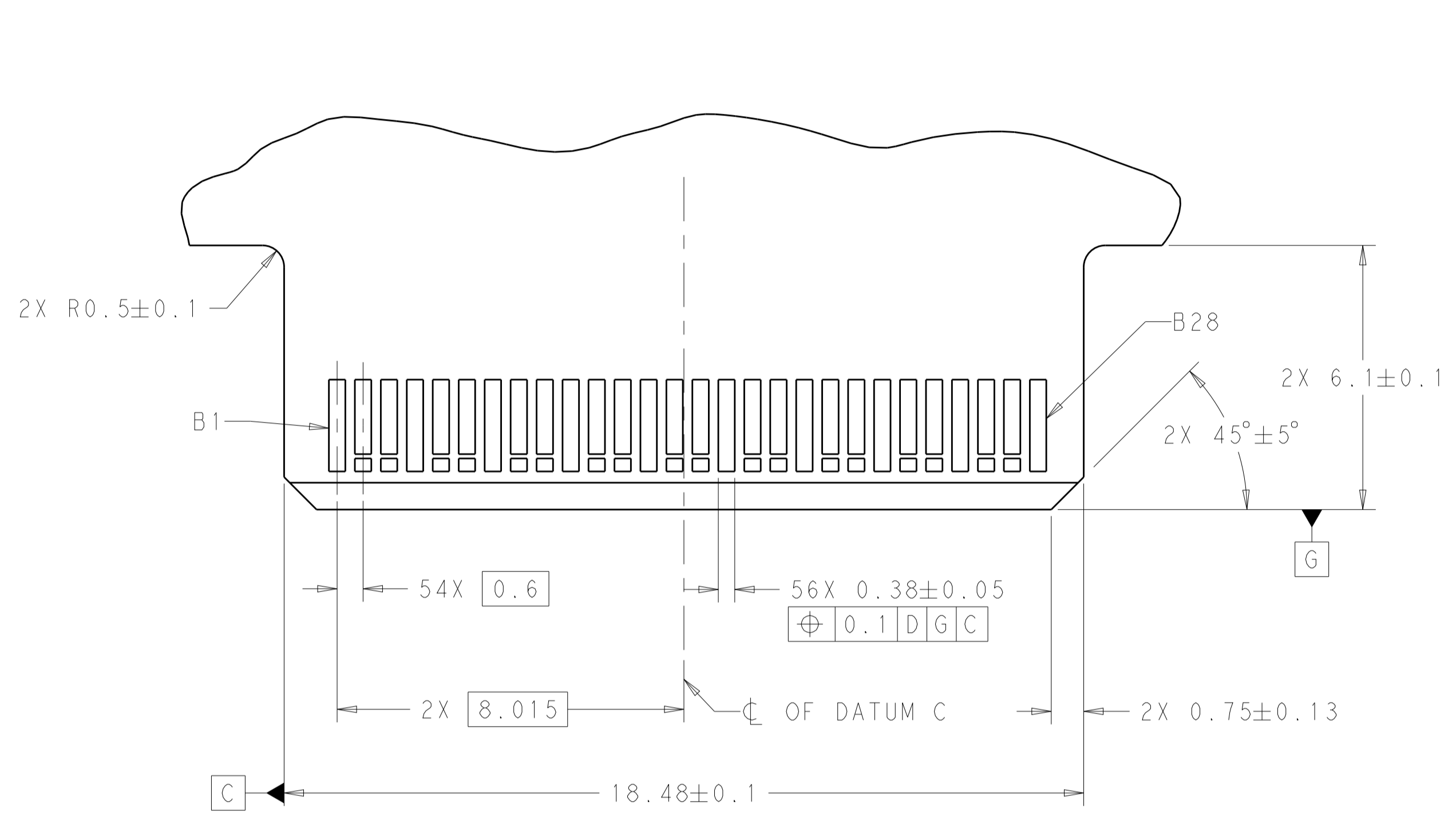

RECOMMENDED PCB OUTLINE DIMENSIONS:  
 TOLERANCE VALUES ARE CRITICAL. PLEASE BE SURE TO DESIGNATE  
 TOLERANCES TO PCB SUPPLIER TO ENSURE OPTIMIZED FUNCTIONALITY.

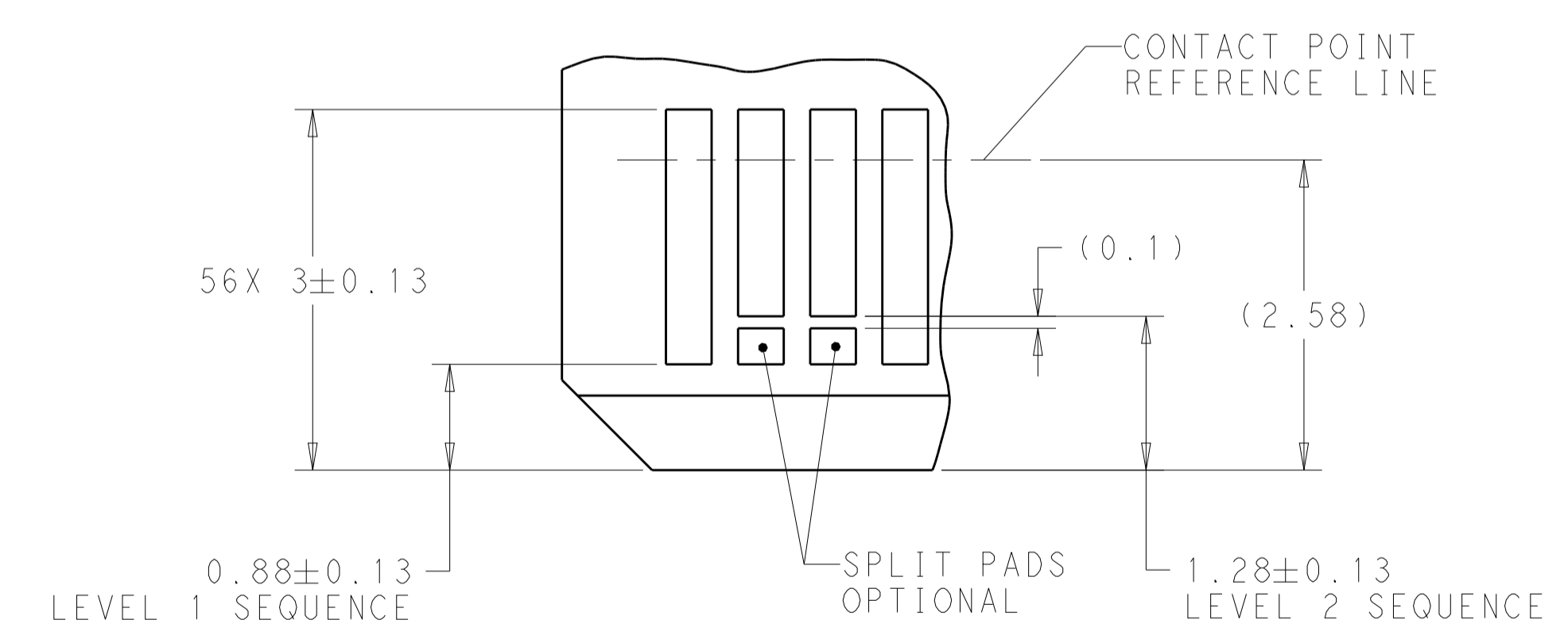

DETAIL J  
 SCALE 20:1

THIS DRAWING IS A CONTROLLED DOCUMENT.		OWN: M. SHIRK 22FEB2018	<b>STE</b> TE Connectivity
DIMENSIONS: mm		CHK: D. HARMON 22FEB2018	
TOLERANCES UNLESS OTHERWISE SPECIFIED:		APVD: D. HARMON 22FEB2018	NAME: RECEPTACLE ASSEMBLY, RIGHT ANGLE, 56 POSITION, SLIVER 2.0
0 PLC ±	1 PLC ±	PRODUCT SPEC	SIZE: 108-130021
2 PLC ±	3 PLC ±	APPLICATION SPEC	RESTRICTED TO
4 PLC ±	ANGLES ±	114-130008	SCALE: 10:1
MATERIAL:	FINISH:	WEIGHT:	SHEET 3 OF 4
CUSTOMER DRAWING		114-130008	REV B

REVISIONS				
P.	LTN	DESCRIPTION	DATE	APVD
-	-	SEE SHEET 1	-	-

TABLE 1: CONNECTOR CONTACT IDENTIFICATION 

CONTACT NUMBER	SIDE A	SIDE B
1	GROUND	GROUND
2	SIGNAL	SIGNAL
3	SIGNAL	SIGNAL
4	GROUND	GROUND
5	SIGNAL	SIGNAL
6	SIGNAL	SIGNAL
7	GROUND	GROUND
8	SIGNAL	SIGNAL
9	SIGNAL	SIGNAL
10	GROUND	GROUND
11	SIGNAL	SIGNAL
12	SIGNAL	SIGNAL
13	GROUND	GROUND
14	SIGNAL	SIGNAL
15	SIGNAL	SIGNAL
16	GROUND	GROUND
17	SIGNAL	SIGNAL
18	SIGNAL	SIGNAL
19	GROUND	GROUND
20	SIGNAL	SIGNAL
21	SIGNAL	SIGNAL
22	GROUND	GROUND
23	SIGNAL	SIGNAL
24	SIGNAL	SIGNAL
25	GROUND	GROUND
26	SIGNAL	SIGNAL
27	SIGNAL	SIGNAL
28	GROUND	GROUND

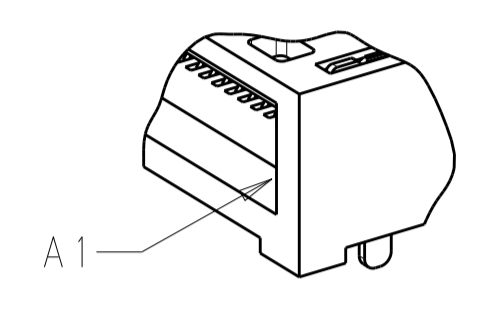

DETAIL B  
SCALE 5:1

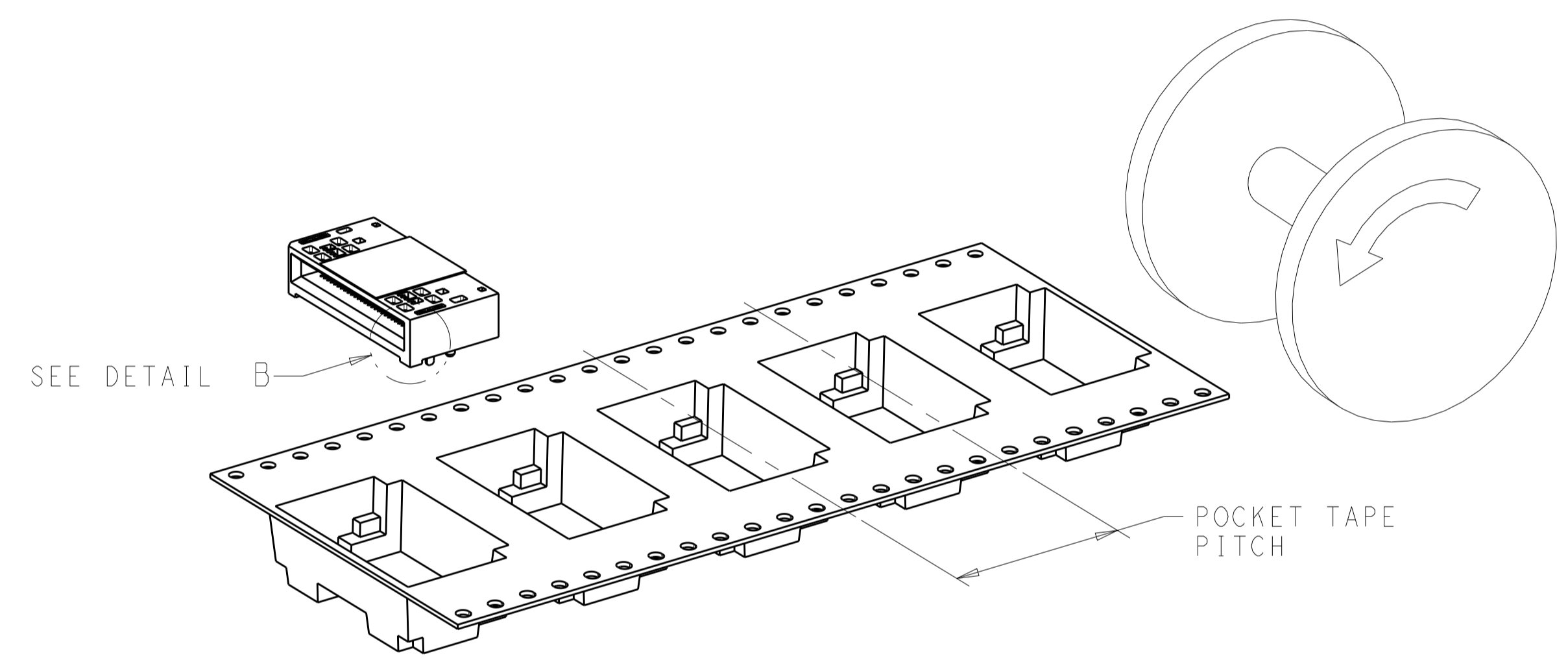

**FIGURE 1**   
 DIRECTION OFF TOP OF REEL  
 FOR USER UNREELING  
 SHOWN AS 2327672-1, 2327672-2 OR 2327672-3  
 SCALE 2:1

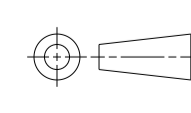
THIS DRAWING IS A CONTROLLED DOCUMENT.		DWN M. SHIRK 22FEB2018 CHK D. HARMON 22FEB2018 APVD D. HARMON 22FEB2018	 TE Connectivity
DIMENSIONS: mm 	TOLERANCES UNLESS OTHERWISE SPECIFIED: 0 PLC ± 1 PLC ± 2 PLC ± 3 PLC ± 4 PLC ± ANGLES ±	NAME RECEPTACLE ASSEMBLY, RIGHT ANGLE, 56 POSITION, SLIVER 2.0 PRODUCT SPEC 108-130021 APPLICATION SPEC 114-130008 WEIGHT - CUSTOMER DRAWING	

单击下面可查看定价，库存，交付和生命周期等信息

[>>TE Connectivity\(泰科\)](#)