

LOC		DIST		P		F		ZONE		LTR		REVISIONS			
DF	H0											DESCRIPTION	DATE	APPD	
												A	REDRAWN PER DF-6290 TA	10-12-92	JW
												B	REV PER 0600-1174-93 TA	12-6-93	JW
												C	REV PER 0600-4864-95 CT	1-96	JW
												D	REV PER 0600-5129-96 TA	4-15-96	DW

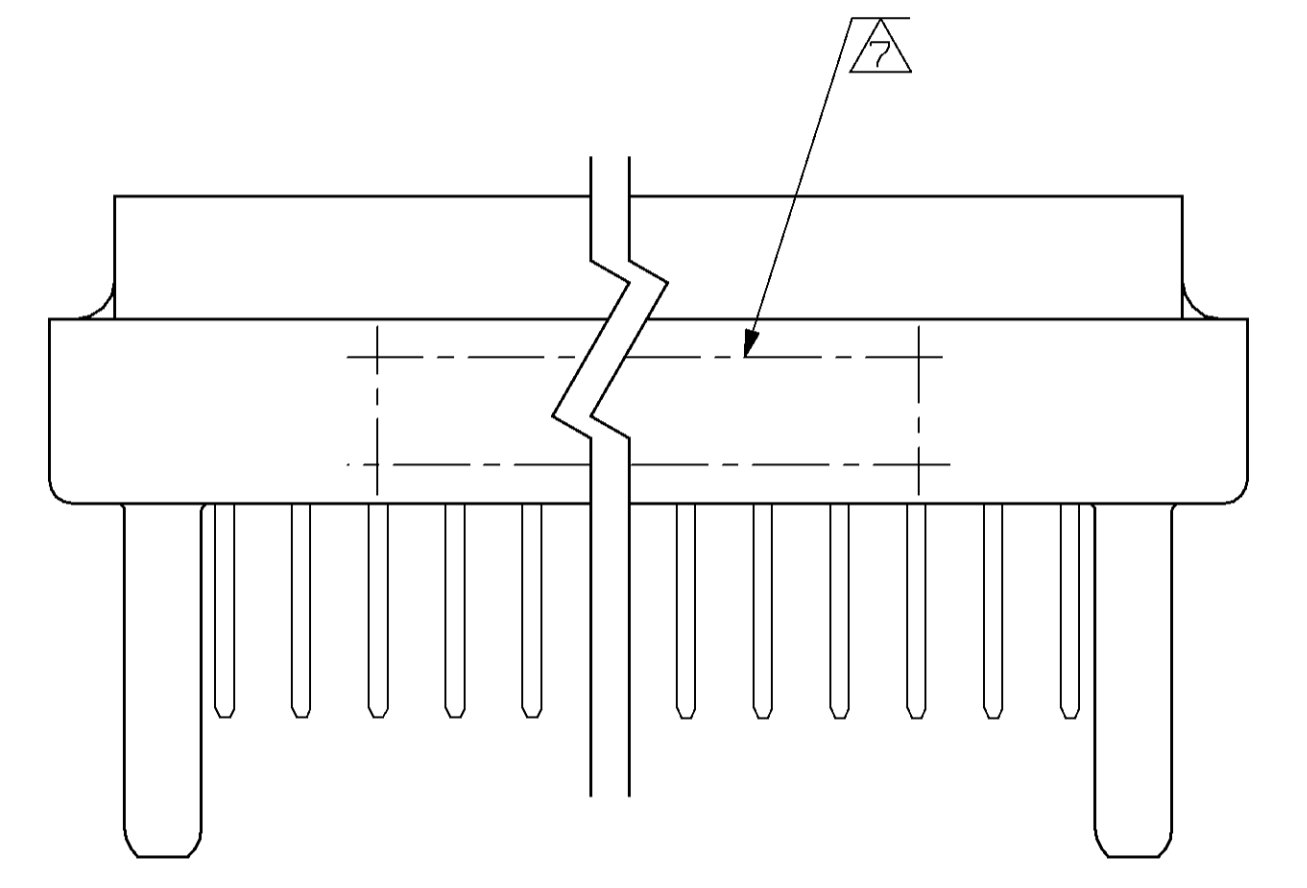

VIEW Z-Z

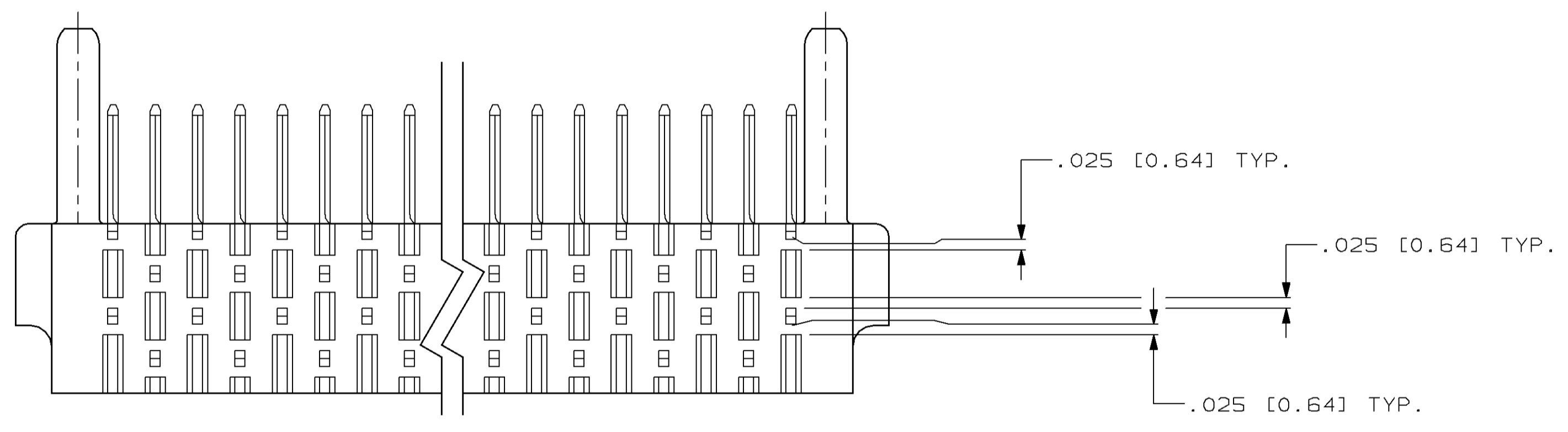
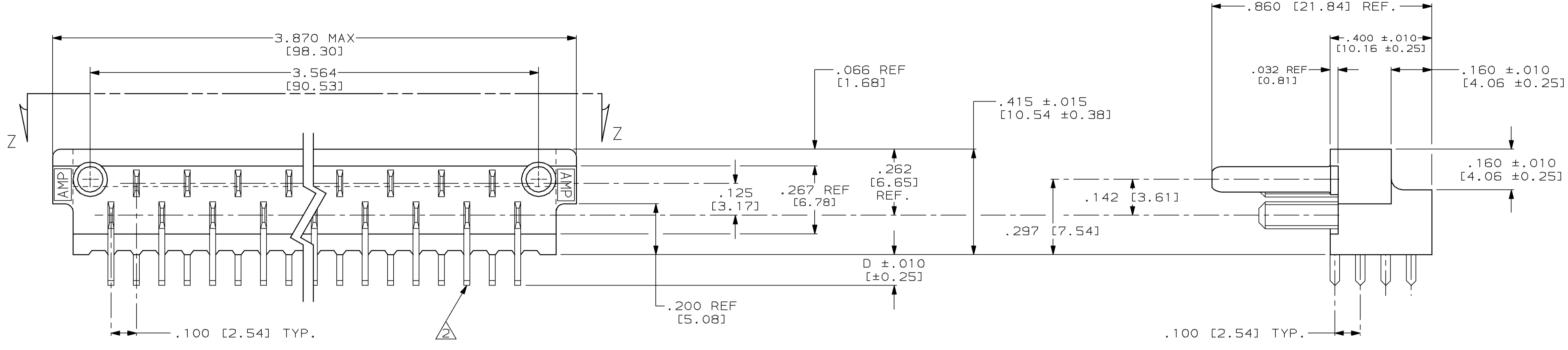
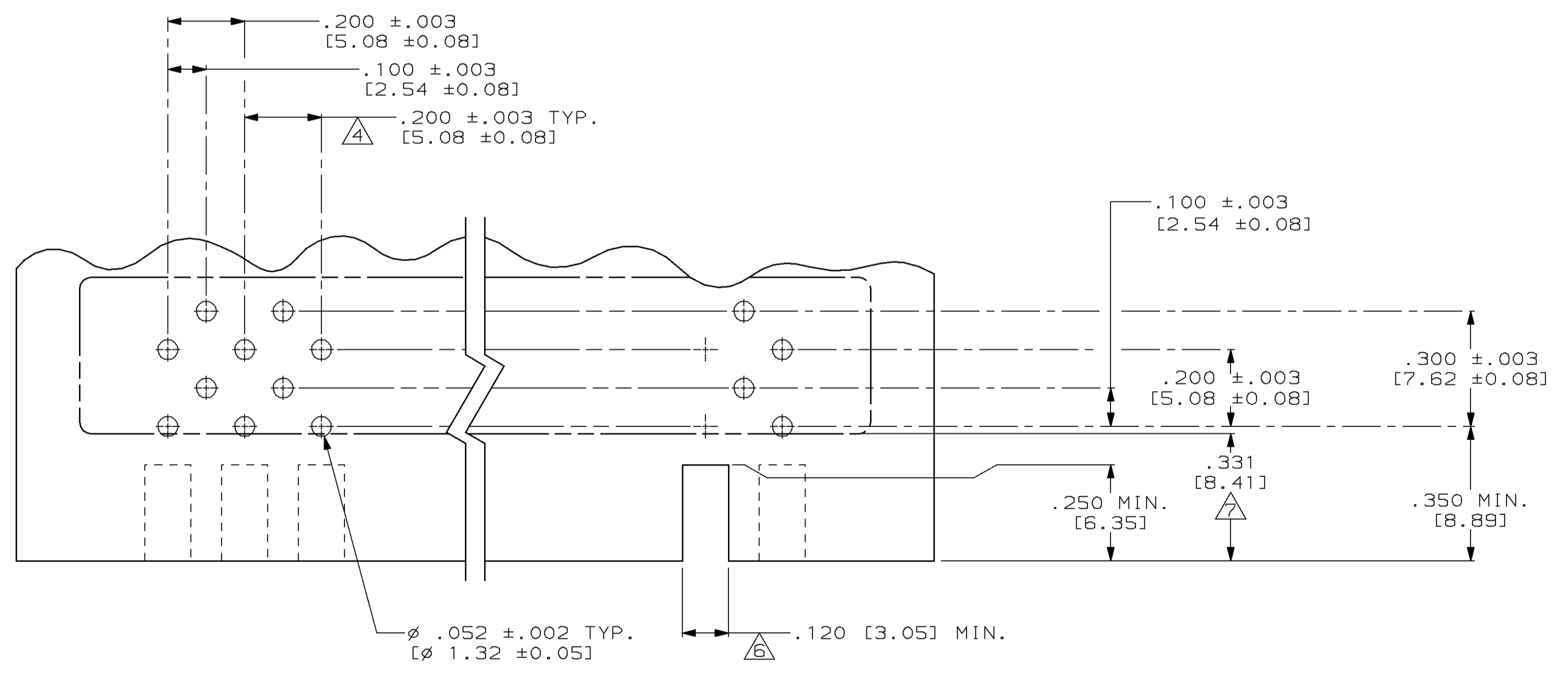

- △ CONTACT FINISH: .000015 THK. GOLD IN THE CONTACT AREA. GOLD FLASH ON THE REMAINDER, ALL OVER .000050 THK. NICKEL.
- △ POST TO BE SOLDER DIPPED. CONN. MUST MEET REQUIREMENTS OF AMP SPEC 109-11-1.
- △ CONTACT MATERIAL: GILDING METAL.
- △ TOLERANCE NON CUMULATIVE.
- △ TAB-HOUSING MATERIAL: FLAME RETARDANT THERMOSET DIALLYL PHTHALATE. COLOR: GREEN
- △ CUT OUT FOR KEYING BOSS, LOCATED WHERE REQD. (OPTIONAL)
- △ AMP P/N & DATE CODE, MARKED WITH .062 ±.015 HIGH CHARACTERS, THIS APPROXIMATE AREA.

DO NOT SCALE PRINT. UNLESS SPECIFIED DIMENSIONS IN INCHES [mm] TOLERANCES ON: 2 PLC DEC ± - 3 PLC DEC ±.005 [0.13] ANGLES ± -		DR T. ALEXANDER 10-9-92	PART NO	
CHK J. WARNER 10-12-92	APPD J. WARNER 10-12-92	APPD T. ALEXANDER 10-12-92	AMP Incorporated Harrisburg, PA 17105-3608	
MATERIAL	FINISH	APPLICATION SPEC	SIZE D	CAGE CODE 00779
△ 3 △ 5	-	-	SCALE 4:1	DRAWING NO 448274
		WEIGHT	SHEET 1 OF 1	

RECOMMENDED P.C. BOARD LAYOUT

ASSEMBLY, AMP BLADE, TAB HOUSING

单击下面可查看定价，库存，交付和生命周期等信息

[>>TE Connectivity\(泰科\)](#)