

Einzelheit H (20:1)  
Detail H (20:1)

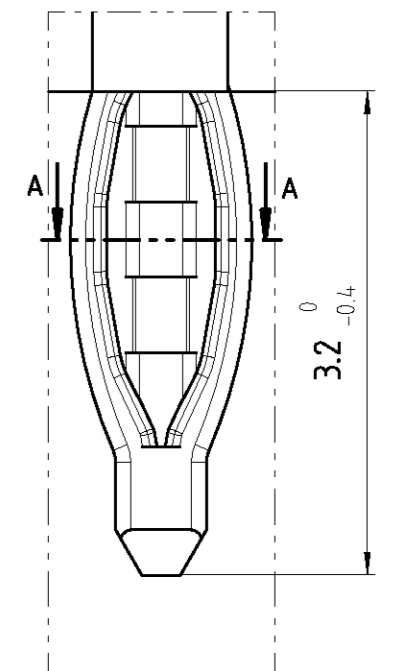

Schnitt AA (20:1)  
Section (20:1)

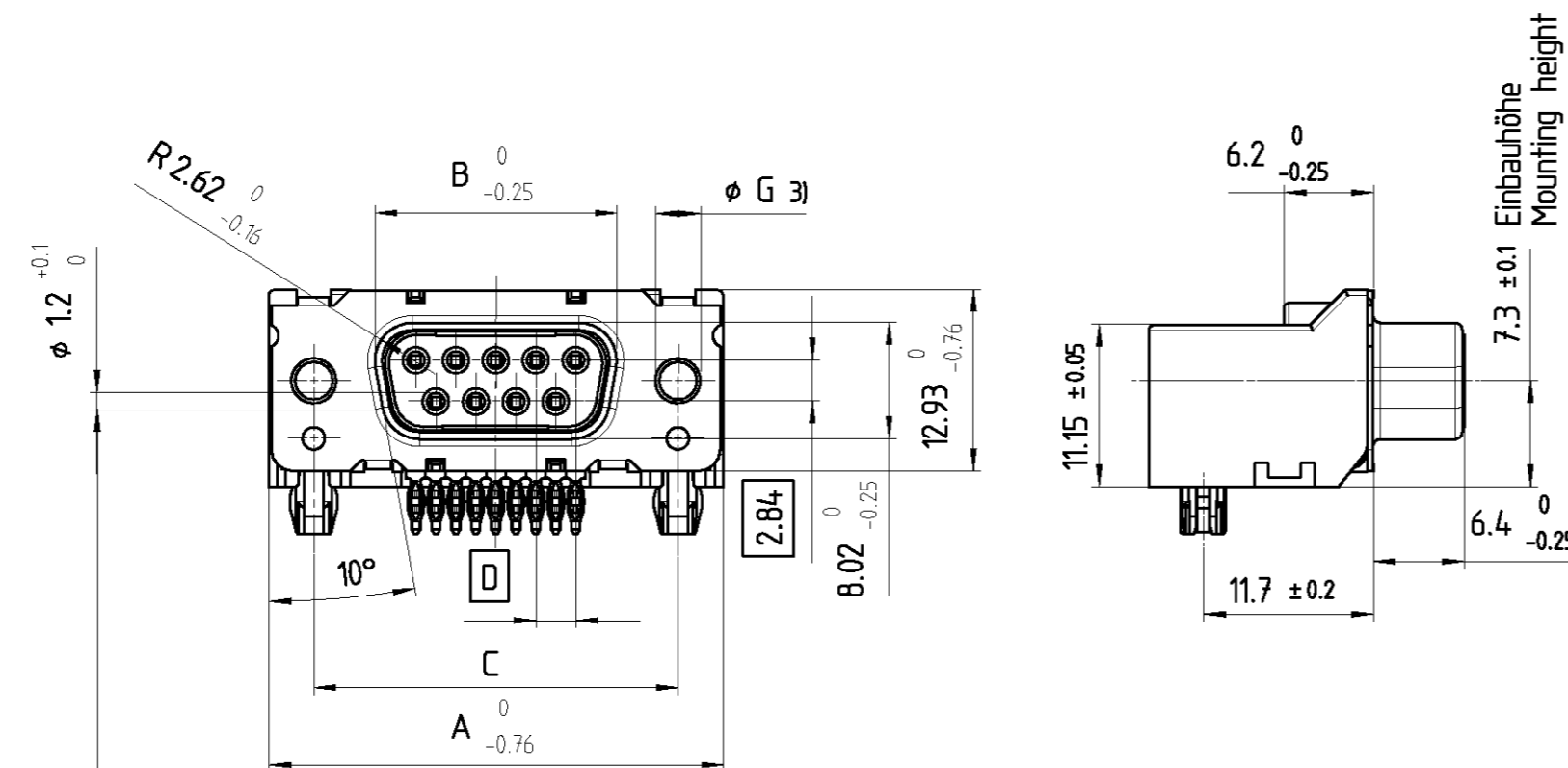
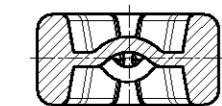

alle Kontakte/all contacts  
 $\phi$  0.13 (M)

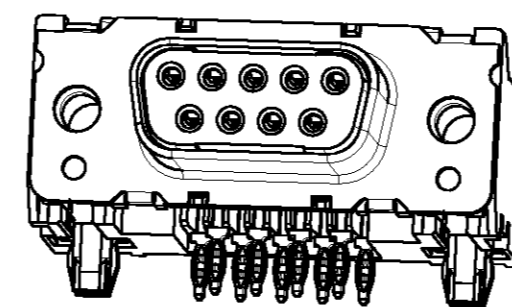
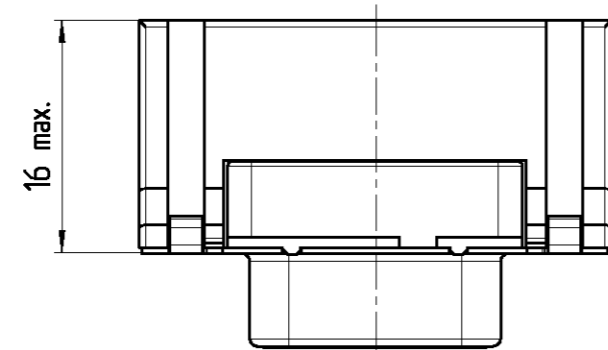

- 4) Plated-through hole ; incl. plating  
suitable for compliant press-in zone  
PCB-plating-through : 5...15  $\mu$ m Sn or SnPb over min. 25  $\mu$ m Cu  
Drilled holes :  $\phi$ 1.15  $\pm$ 0.025 and  $\phi$ 3.15  $\pm$ 0.025
- 3) torquereffention  $\geq$  70 Ncm
- 2) according to DIN 41611 p.5, DIN IEC 353-5; incl. plating
- 1) according to DIN 41652 p.2 and p.4
  
- 4) Durchmetallisierte Löcher; incl. Oberflächenbehandlung  
Geeignet für elastische Einpreßzonen  
Metallierung des Loches: 5...15  $\mu$ m Sn oder SnPb über min. 25  $\mu$ m Cu  
Bohrdurchmesser:  $\phi$ 1.15  $\pm$ 0.025 und  $\phi$ 3.15  $\pm$ 0.025
- 3) Verdrehsicherheit  $\geq$  70 Nm
- 2) Nach DIN 41611 T.5, DIN IEC 352-5; incl. Oberflächenbehandlung
- 1) Nach DIN 41652 T.2 und T.4

Sachnr./Ordercode V23529-R1****-	Polzahl n Contacts n	Maß/Dimension			
		A	B	C	D
B*09	09	31.19	16.46	25.00 $^{+0.12}_{-0.13}$	2.74
B*15	15	39.52	24.79	33.30 $^{+0.15}_{-0.1}$	2.74
B*25	25	53.42	38.50	47.04 $^{+0.13}_{-0.13}$	2.76
B*37	37	69.70	54.96	63.50 $^{+0.13}_{-0.13}$	2.76

Anforderungsstufe 1)  
performance level 1)

Sachnr./Ordercode V23529-	Maß/Dimension $\phi$ G
R1*02-B***	M3
R1*03-B***	4-40UNC

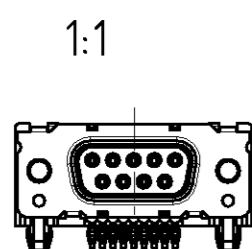

Dargestellt wird die 9-polige Ausführung V23529-R1202-B209  
On the drawing : the 9 pole version V23529-R1202-B209

<small>PROPRIETARY</small> THIS INFORMATION IS CONFIDENTIAL AND PROPRIETARY TO TYCO ELECTRONICS CORPORATION AND ITS WORLDWIDE SUBSIDIARIES AND AFFILIATES. IT MAY NOT BE DISCLOSED TO ANYONE, OTHER THAN TYCO ELECTRONICS PERSONNEL, WITHOUT WRITTEN AUTHORIZATION FROM TYCO ELECTRONICS CORPORATION, HARRISBURG, PENNSYLVANIA USA.		CHANGES TO THIS DRAWING MUST BE DONE ONLY IN CAD	PAPER SIZE A2
APPLICABLE SPEC.:		FINISH	
DIMENSIONS APPLY		PLATING	
<b>tyco</b> Tyco Electronics Corporation Oostkamp - Belgium		SCALE 2:1; 20:1; 1:1	WEIGHT
MATERIAL			
DATE 07.02.96 NAME Sterckx APP: EC CS CI		NAME Sub-D 90° abgewinkelt Standard Einpreß Buchsenleiste D-Sub 90° angled standard press fit Socket	
03 W000/2525 25.05.00 KV 02 W097/4510 14.8.97 RST 01 23.1.97 RST 51 7.2.96 RST	TOLERANCE UNLESS SPECIFIED OTHERWISE		NO. V23529-R****-B****-7427
REV. CHANGE ORDER	DATE	APP.	SHT. 1 OF 2

PROPRIETARY: THIS INFORMATION IS CONFIDENTIAL AND PROPRIETARY TO TYCO ELECTRONICS CORPORATION AND ITS WORLDWIDE SUBSIDIARIES AND AFFILIATES. IT MAY NOT BE DISCLOSED TO ANYONE, OTHER THAN TYCO ELECTRONICS PERSONEL, WITHOUT WRITTEN AUTHORIZATION FROM TYCO ELECTRONICS CORPORATION, HARRISBURG, PENNSYLVANIA USA.

Ausführung mit Gewindebolzen  
 Version with studbolt  
 V23529-R1\*04/R1\*05-B\*\*\*

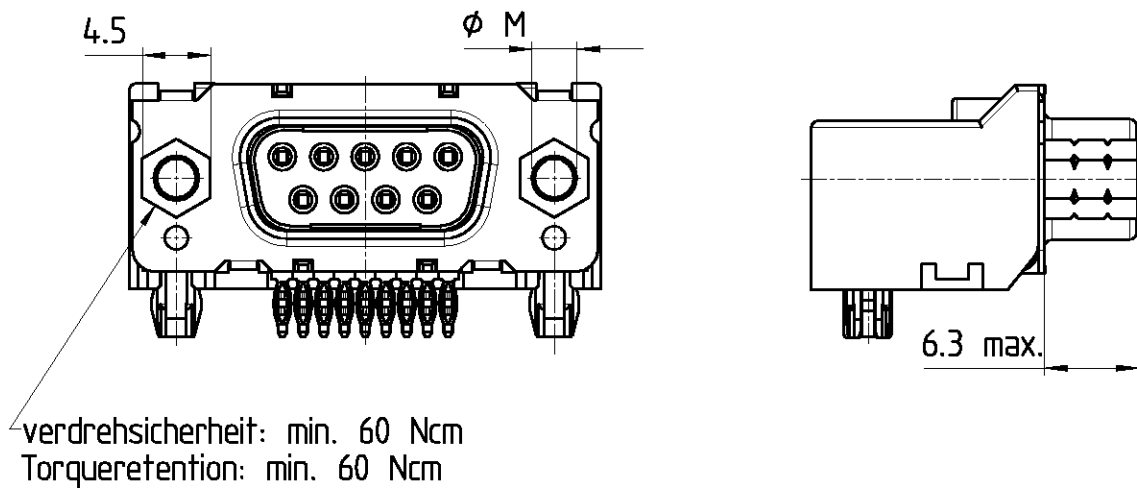

Sachnr./Ordercode V23529-	Maß/Dimension $\phi M$
S1*04-B***	M3
S1*05-B***	4-40UNC

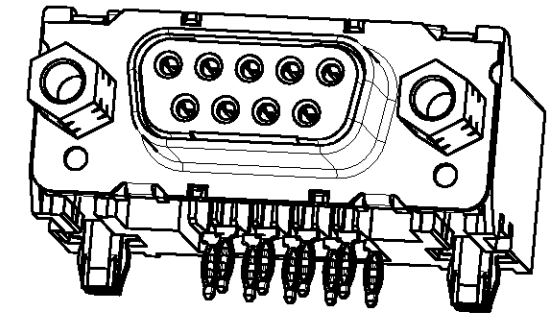

Leiterplattenbohrung (2:1)  
 PCB hole pattern (2:1)

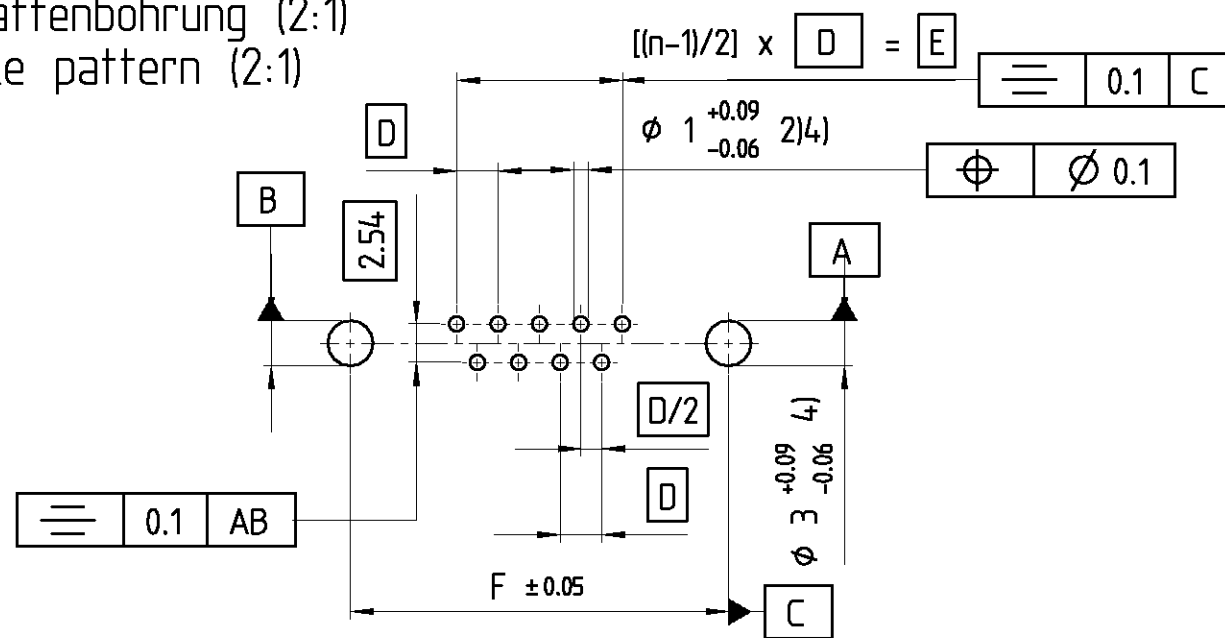

Sachnr./Ordercode V23529-S1***-	Polzahl n Contacts n	Maß/Dimension		
		D	E	F
B*09	09	2.74	10.96	25.00
B*15	15	2.74	19.18	33.30
B*25	25	2.76	33.12	47.04
B*37	37	2.76	49.68	63.50

Anforderungsstufe 1)  
 performance level 1)

Verpreßhinweis  
 press-in information

Einpressen über Kunststoff mit:  
 - 2-Hub-Press 60kN : V23599-P2006-E2  
 - Einpreßmaschine 60/100 kN : V23599-E3005-E1...4  
 Zu verwendenden Werkzeuge :  
 - Drückstück : V23599-E6006-E4  
 - Amboß ; V23599-E5013-E3  
 Einstellhöhe : Abstand zwischen LP und  
 angedrucktem Stempel : 11.15...11.3mm

pressing in via the plastic body :  
 - 2-stroke press 60kN : V23599-P2006-E2  
 - press-fit machine 60/100kN : V23599-E3005-E1...4

pressing-i tools :  
 -Compression tool : V23599-E6006-E4  
 -anvil : V23599-E5013-E3  
 set-up heights : distance between PCB and  
 compression tool : 11.15...11.3 mm

Erläuterungen siehe Seite 1  
 Remarks see page 1

APPLICABLE SPEC.:		FINISH	
DIMENSIONS APPLY		PLATING	
SCALE 2:1		WEIGHT	
MATERIAL			
NAME		Sub-D 90° abgewinkelt Standard Einpreß Buchsenleiste D-Sub 90° angled standard press fit Socket	
NO.		V23529-R****-B****-7427	
SHT. 2-		DF 2	
REV. CHANGE ORDER		DATE APP.	

Tyco Electronics Corporation Oostkamp - Belgium		DIMENSIONS IN MM	
DATE	7.2.96		
NAME	Sterckx		
DEP.	CI PD		
03	W000/2525	25.05.00	KV
02	W097/4510	14.8.97	RST
01		23.1.97	RST
51		7.2.96	RST
TOLERANCE UNLESS SPECIFIED OTHERWISE			

单击下面可查看定价，库存，交付和生命周期等信息

[>>TE Connectivity\(泰科\)](#)