

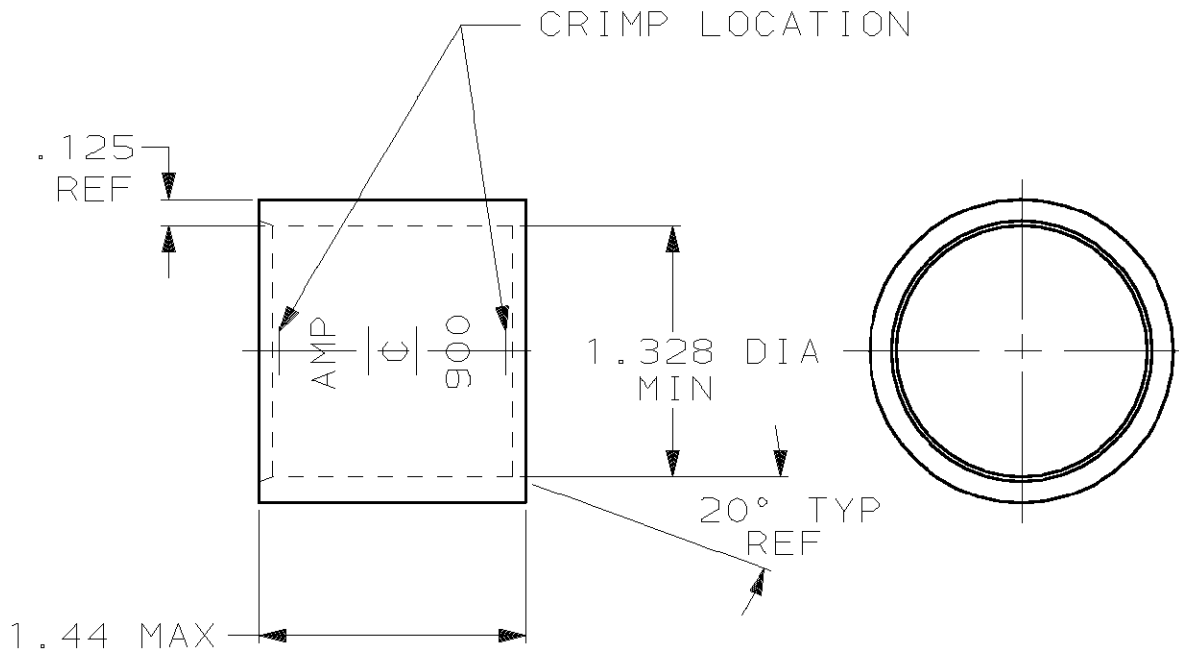

LOC G	DIST 86	P	F	REVISIONS		
		LTR		DESCRIPTION	DATE	APPROVED
		F		REV PER OG3A-0637-01	030CT02	JR/MS

1 PREPRODUCTION - FASR REQ



THIS DRAWING IS UNPUBLISHED. BY AMP INCORPORATED. ALL INTERNATIONAL RIGHTS RESERVED. 19

© COPYRIGHT 19

850-950 MCM	CLEANED, UNPLATED	1-324455-0
	TIN PL PER ASTM B545 .000150 MIN THK	324455
RANGE	FINISH	PART NO

DO NOT SCALE PRINT. UNLESS SPECIFIED DIMENSIONS IN INCHES TOLERANCES ON: 2 PLC DEC ± - 3 PLC DEC ± - ANGLES ± -	DR 1/16/89 P FORTNEY	AMP INCORPORATED Harrisburg, Pa. 17105		
	CHK 6/20/89 MS FEHER			
	MATERIAL COPPER ASTM-B-75 ANNEALED	APPD 6/20/89 WJ VOCKROTH	NAME WIRE SPLICE, PARALLEL, AMPOWER, WIRE SIZE: 900 MCM	
FINISH SEE TABLE	APPD 6/20/89 R ADAMS	SIZE A	FSCM NO 00779	DRAWING NO 324455
	PRODUCT SPEC -	SCALE 1:1		SHEET 1 OF 1
	APPLICATION SPEC -			
	WEIGHT .263 LB.			

单击下面可查看定价，库存，交付和生命周期等信息

[>>TE Connectivity\(泰科\)](#)