

REVISIONS				
REV	DATE	BY	CHK	APPV
B	25OCT2021	SCB	KJK	

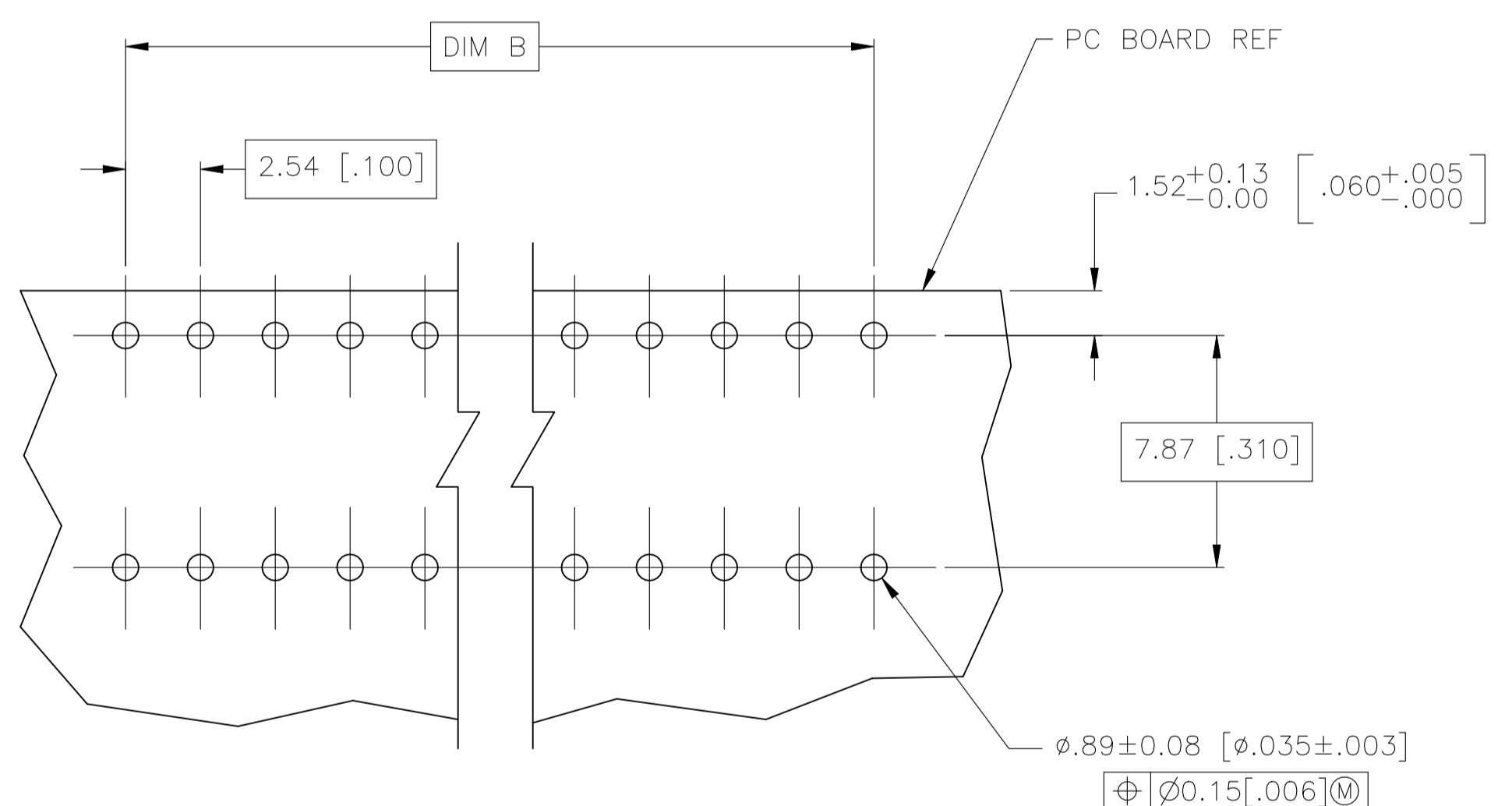
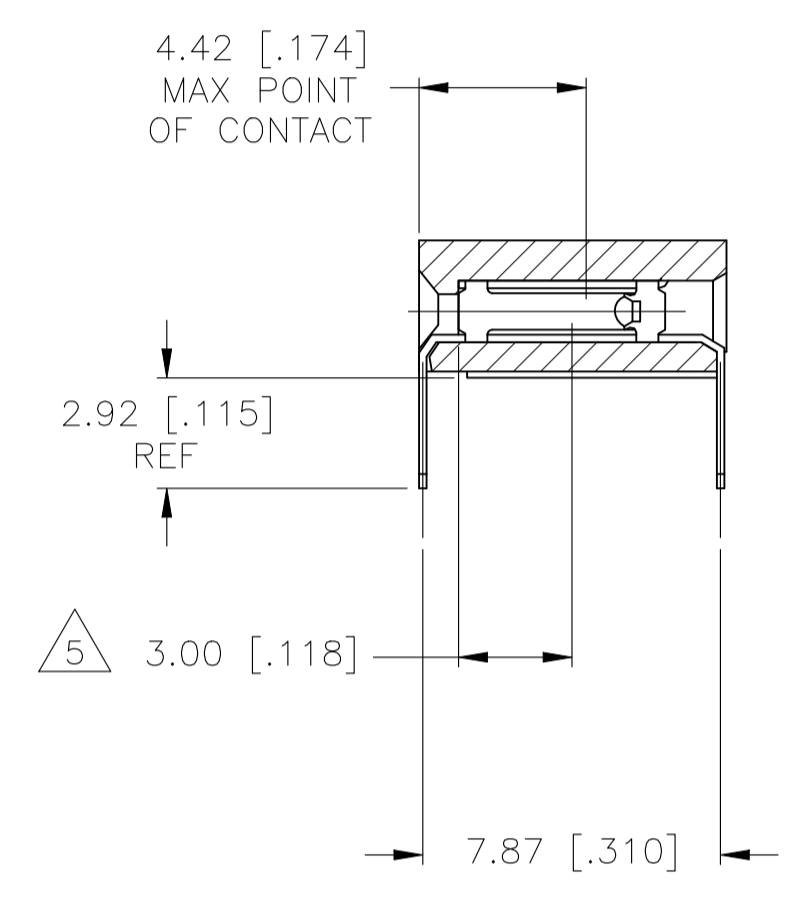
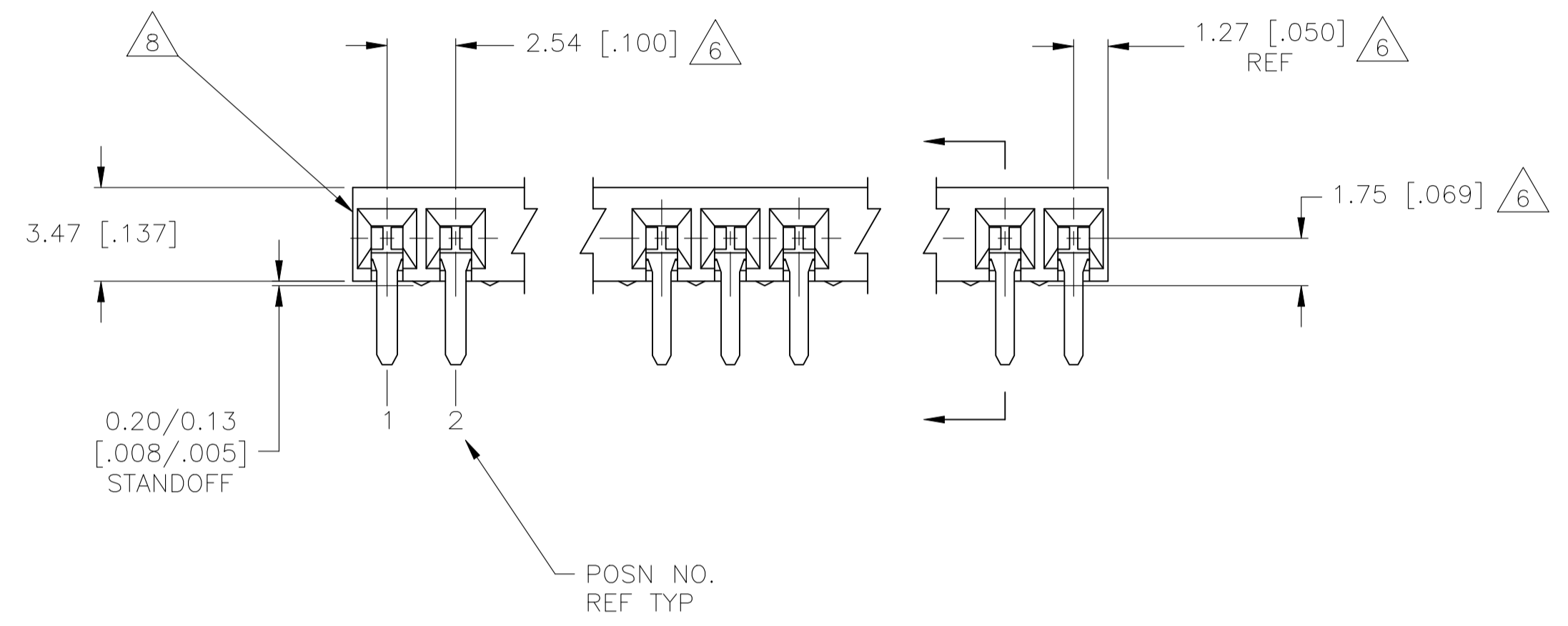
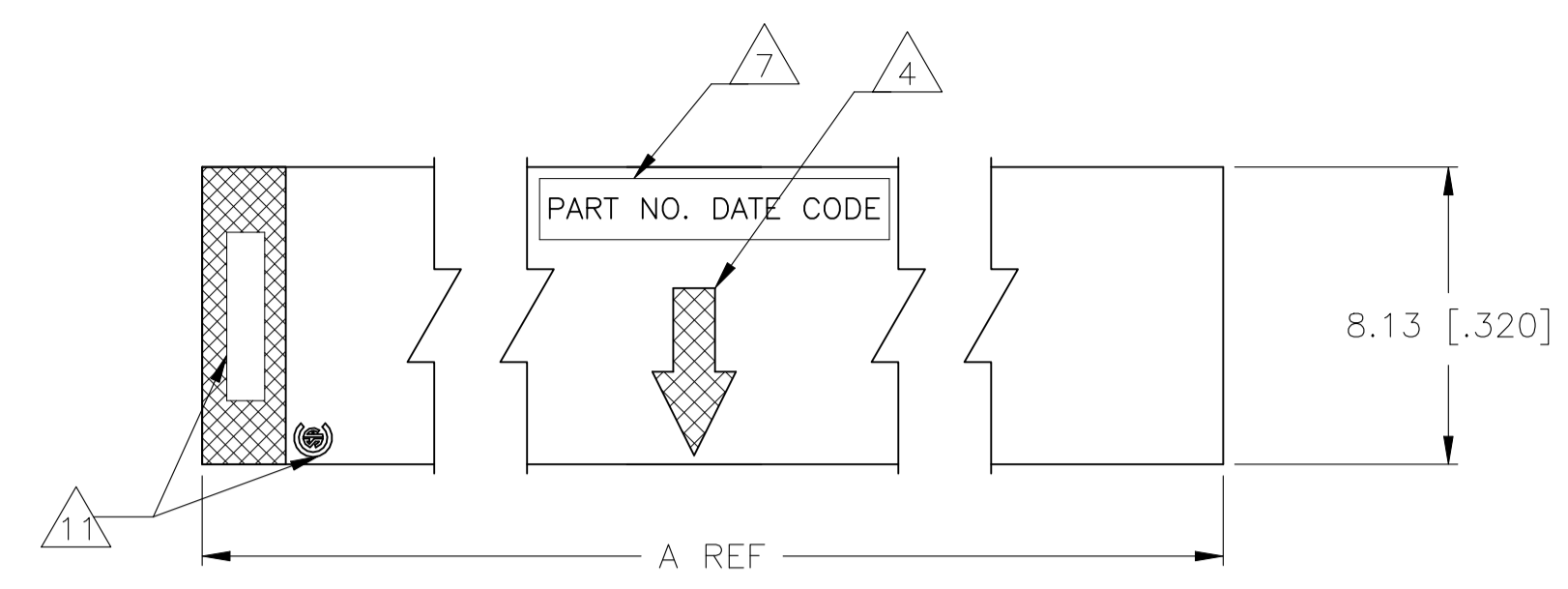

RECOMMENDED PC BOARD LAYOUT

- 1 HOUSING MATERIAL: GLASS FILLED POLYESTER, COLOR- BLACK
- 2 CONTACT MATERIAL: PHOSPHOR BRONZE
- 3 CONTACT FINISH: 3.81-7.62(.000150-.000300) MATTE TIN ALL OVER 0.00127(.000050)MIN NICKEL ENTIRE CONTACT.
- 4 MOLDED IN ARROW DESIGNATES THE MATING FACE OF THE CONNECTOR
- 5 POINT OF MEASUREMENT FOR PLATING THICKNESS OF CONTACT AREA
- 6 DIMENSIONS PERTAIN TO HOUSING CAVITY CENTERLINES
- 7 PART NUMBER AND DATE CODE MARKED IN APPROXIMATE LOCATION SHOWN, EITHER END.
- 8 ALTERNATE LOCATION FOR DATE CODE FOR 2 AND 3 POSITION.
- 9 NO PART NUMBER MARKING REQUIRED FOR THIS PART.
- 10 ROHS 2002/95/EC COMPLIANT.
- 11 TE LOGO AND CSA LOGO ARE MOLDED INTO HOUSING, THIS LOCATION

162.56[6.400]	165.10[6.500]	65	6-5535677-4
160.02[6.300]	162.56[6.400]	64	6-5535677-3
157.48[6.200]	160.02[6.300]	63	6-5535677-2
154.94[6.100]	157.48[6.200]	62	6-5535677-1
152.40[6.000]	154.94[6.100]	61	6-5535677-0
149.86[5.900]	152.40[6.000]	60	5-5535677-9
147.32[5.800]	149.86[5.900]	59	5-5535677-8
144.78[5.700]	147.32[5.800]	58	5-5535677-7
139.70[5.500]	144.78[5.700]	57	5-5535677-6
139.70[5.500]	142.24[5.600]	56	5-5535677-5
137.16[5.400]	139.70[5.500]	55	5-5535677-4
134.62[5.300]	137.16[5.400]	54	5-5535677-3
132.08[5.200]	134.62[5.300]	53	5-5535677-2
129.54[5.100]	132.08[5.200]	52	5-5535677-1
127.00[5.000]	129.54[5.100]	51	5-5535677-0
124.46[4.900]	127.00[5.000]	50	4-5535677-9
121.92[4.800]	124.46[4.900]	49	4-5535677-8
119.38[4.700]	121.92[4.800]	48	4-5535677-7
116.84[4.600]	119.38[4.700]	47	4-5535677-6
114.30[4.500]	116.84[4.600]	46	4-5535677-5
111.76[4.400]	114.30[4.500]	45	4-5535677-4
109.22[4.300]	111.76[4.400]	44	4-5535677-3
106.68[4.200]	109.22[4.300]	43	4-5535677-2
104.14[4.100]	106.68[4.200]	42	4-5535677-1
101.16[4.000]	104.14[4.100]	41	4-5535677-0
96.52[3.800]	99.06[3.900]	39	3-5535677-9
93.98[3.700]	96.52[3.800]	38	3-5535677-8
91.44[3.600]	93.98[3.700]	37	3-5535677-7
88.90[3.500]	91.44[3.600]	36	3-5535677-6
86.36[3.400]	88.90[3.500]	35	3-5535677-5
83.82[3.300]	86.36[3.400]	34	3-5535677-4
81.28[3.200]	83.82[3.300]	33	3-5535677-3
78.74[3.100]	81.28[3.200]	32	3-5535677-2
76.20[3.000]	78.74[3.100]	31	3-5535677-1
71.12[2.800]	73.66[2.900]	29	3-5535677-0
68.58[2.700]	71.12[2.800]	28	2-5535677-9
66.04[2.600]	68.58[2.700]	27	2-5535677-8
63.50[2.500]	66.04[2.600]	26	2-5535677-7
60.96[2.400]	63.50[2.500]	25	2-5535677-6
58.42[2.300]	60.96[2.400]	24	2-5535677-5
55.88[2.200]	58.42[2.300]	23	2-5535677-4
50.80[2.000]	53.34[2.100]	21	2-5535677-3
99.06[3.900]	101.16[4.000]	40	2-5535677-2
73.66[2.900]	76.20[3.000]	30	2-5535677-1
48.26[1.900]	50.80[2.000]	20	2-5535677-0
45.72[1.800]	48.26[1.900]	19	1-5535677-9
43.18[1.700]	45.72[1.800]	18	1-5535677-8
40.64[1.600]	43.18[1.700]	17	1-5535677-7
38.10[1.500]	40.64[1.600]	16	1-5535677-6
35.56[1.400]	38.10[1.500]	15	1-5535677-5
33.02[1.300]	35.56[1.400]	14	1-5535677-4
27.94[1.100]	30.48[1.200]	12	1-5535677-3
25.40[1.000]	27.94[1.100]	11	1-5535677-2
22.86[.900]	25.40[1.000]	10	1-5535677-1
17.78[.700]	22.86[.900]	9	1-5535677-0
17.78[.700]	20.32[.800]	8	5535677-9
10.16[.400]	12.70[.500]	5	5535677-8
7.62[.300]	10.16[.400]	4	5535677-7
5.08[.200]	7.62[.300]	3	5535677-6
2.54[.100]	5.08[.200]	2	5535677-5
53.34[2.100]	55.88[2.200]	22	5535677-4
30.48[1.200]	33.02[1.300]	13	5535677-3
15.24[.600]	17.78[.700]	7	5535677-2
12.70[.500]	15.24[.600]	6	5535677-1

THIS DRAWING IS A CONTROLLED DOCUMENT.		DIN BSV 05NOV04		TE Connectivity AMPMODU II RECEPTACLE ASSEMBLY, HORIZONTAL 100 CL, SINGLE ROW, CLOSED-ENTRY, SHORT POINT OF CONTACT, END-TO-END STACKABLE(LEAD FREE)	
DIMENSIONS: mm		TOLERANCES UNLESS OTHERWISE SPECIFIED:			
0. PLC ± - 1. PLC ± - 2. PLC ± - 3. PLC ± 0.13(.005) 4. PLC ± - ANGLES ± -		0. PLC ± - 1. PLC ± - 2. PLC ± - 3. PLC ± 0.13(.005) 4. PLC ± - ANGLES ± -		NAME: J. OLSON PRODUCT SPEC: APPLICATION SPEC: SIZE: A1 CAGE CODE: 00779 DRAWING NO: 5535677 RESTRICTED TO:	
MATERIAL: 1 2		FINISH: 3		WEIGHT: - CUSTOMER DRAWING: SCALE 5:1 SHEET 1 OF 1 REV B	

单击下面可查看定价，库存，交付和生命周期等信息

[>>TE Connectivity\(泰科\)](#)