

REVISIONS					
#	DATE	DESCRIPTION	DATE	OWN	APVD
C4		REVISED PER ECO-16-009081	02JUL2014	NK	MM
C5		DETAIL E, F, G AND H ADDED	07MAR2016	FP	NG
C6		PART 3-284041-4 (DETAIL J) ADDED	05APR2016	FP	NG

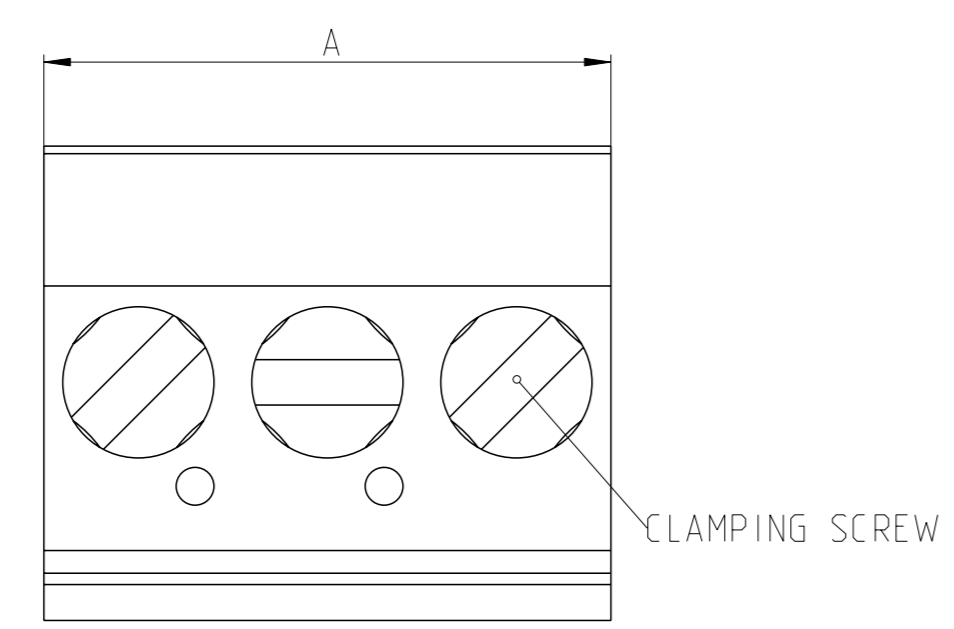

- NOTES
- MATERIALS AND FINISH:
 HOUSING: PA 6-6, UL 94-V0, COLOR: GREEN.
 CLAMP: COPPER ALLOY, NICKEL PLATED.
 CONTACT SPRING : COPPER ALLOY, FINISH: SEE TABLE
 CLAMPING SCREW: M3, COPPER ALLOY, NICKEL PLATED.
 - MECHANICAL
 MAX. INSERTION FORCE PER HOLE : 3N
 MIN. WITHDRAWAL FORCE PER HOLE: 1.5N
 WIRE STRIPPING LENGTH : 6-7.5 mm
 RECOMMENDED/ HIGHEST TIGHTENING TORQUE : 0.5/0.6 Nm
 - ELECTRICAL
 WIRE RANGE : 30 - 12 AWG
 MAX. VOLTAGE : 300 V
 MAX CURRENT : 15 A
 CONTACT RESISTANCE : <15 m Ohm
 INSULATION RESISTANCE : >1000 M Ohm (500V DC)
 - OPERATING TEMPERATURE RANGE: -40 °C TO +110 °C

- △ TOLERANCE NOT CUMULATIVE.
- △ PRELIMINARY
- △ SPECIAL MARKING TO BE PERMANENT BLACK LETTERING
- △ SPECIAL MARKING TO BE IN PERMANENT BLACK INK
- △ SPECIAL MARKING TO BE IN PERMANENT WHITE INK (SEE BACKGROUND COLOUR)

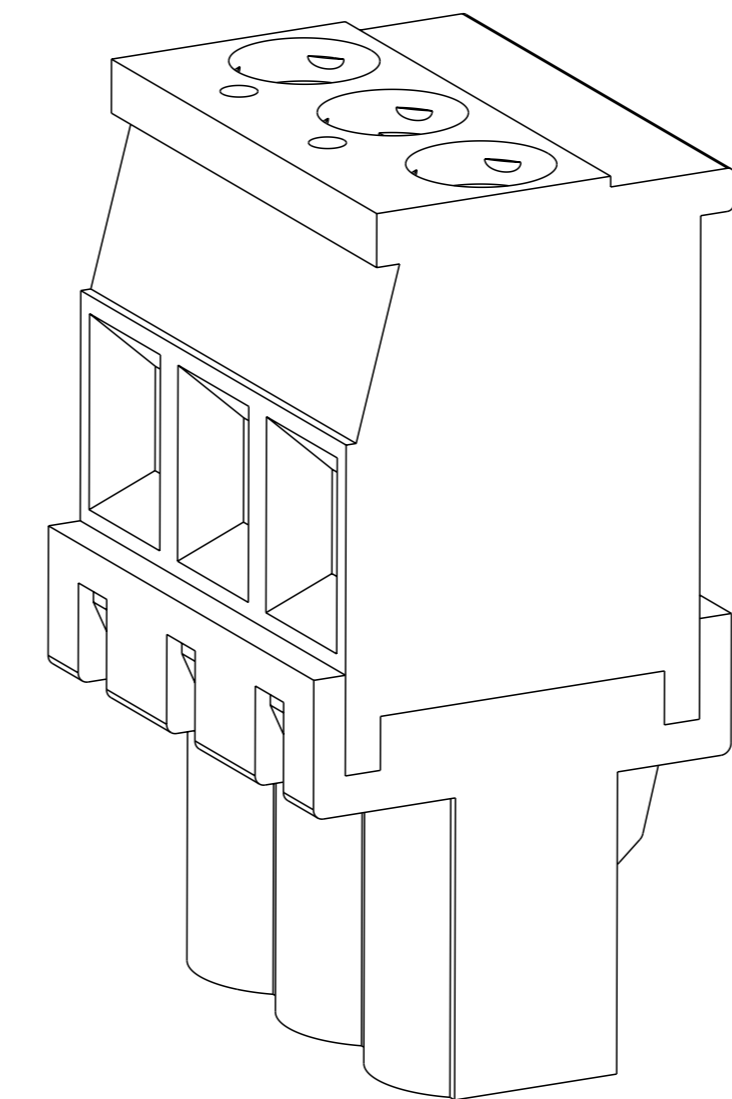
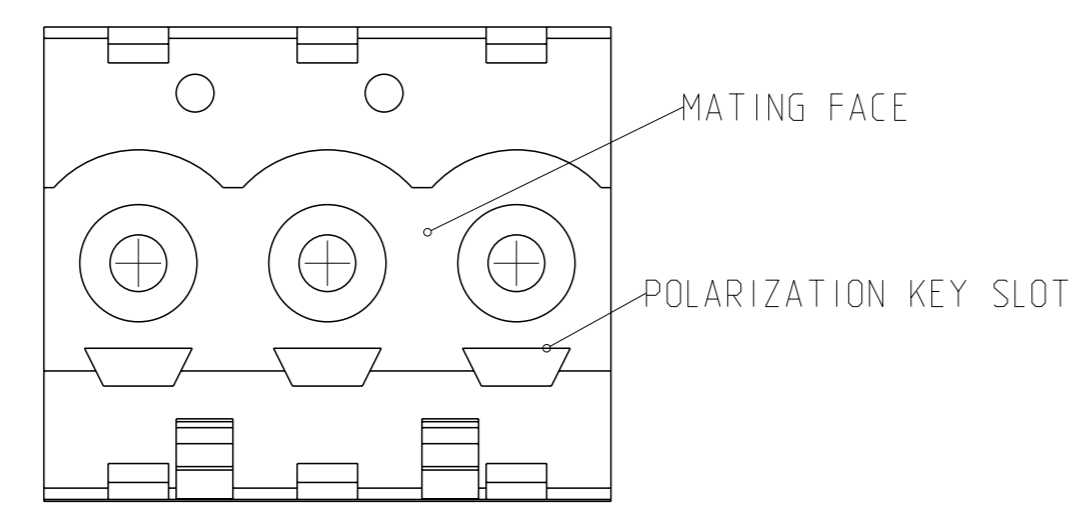
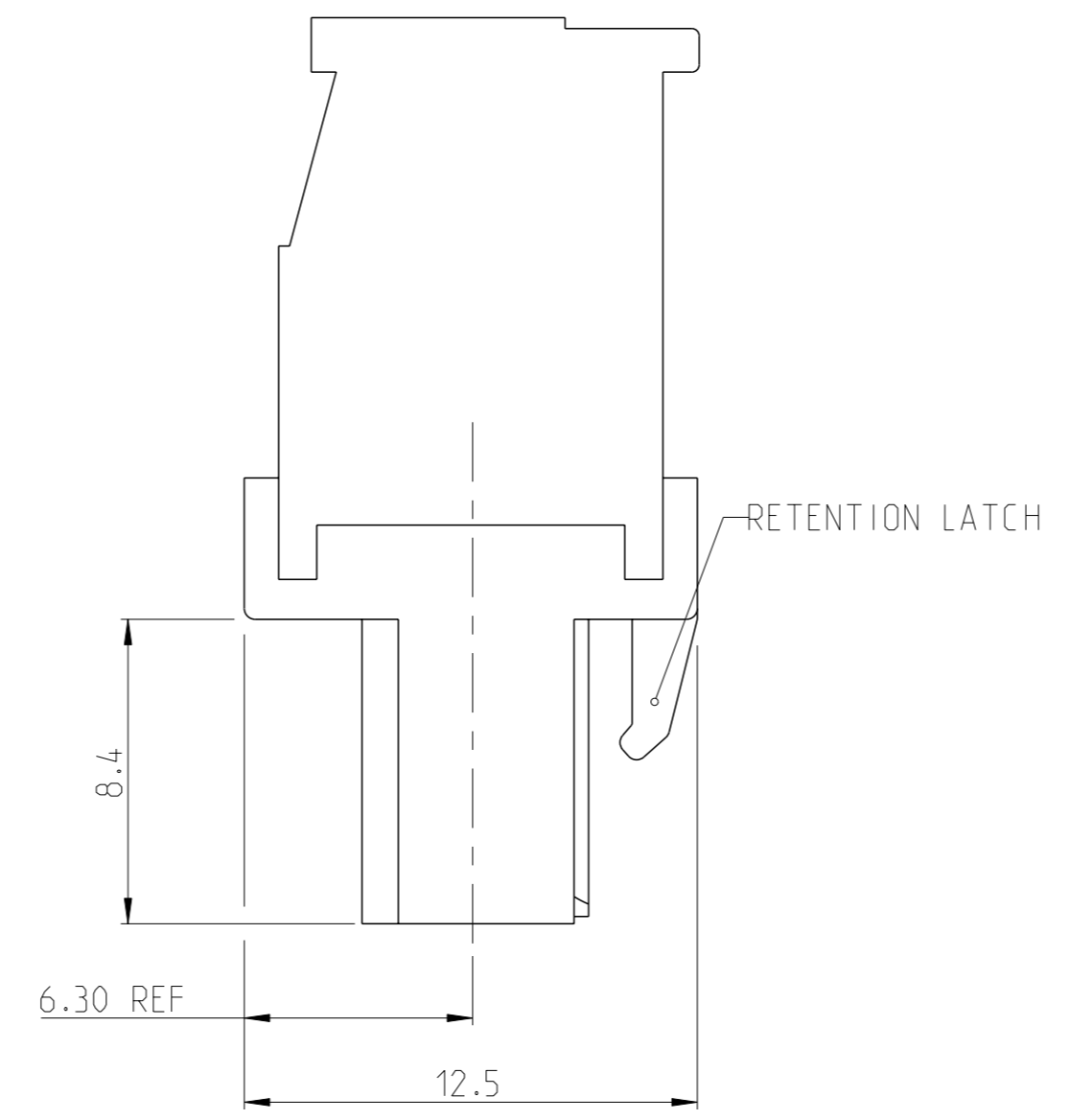
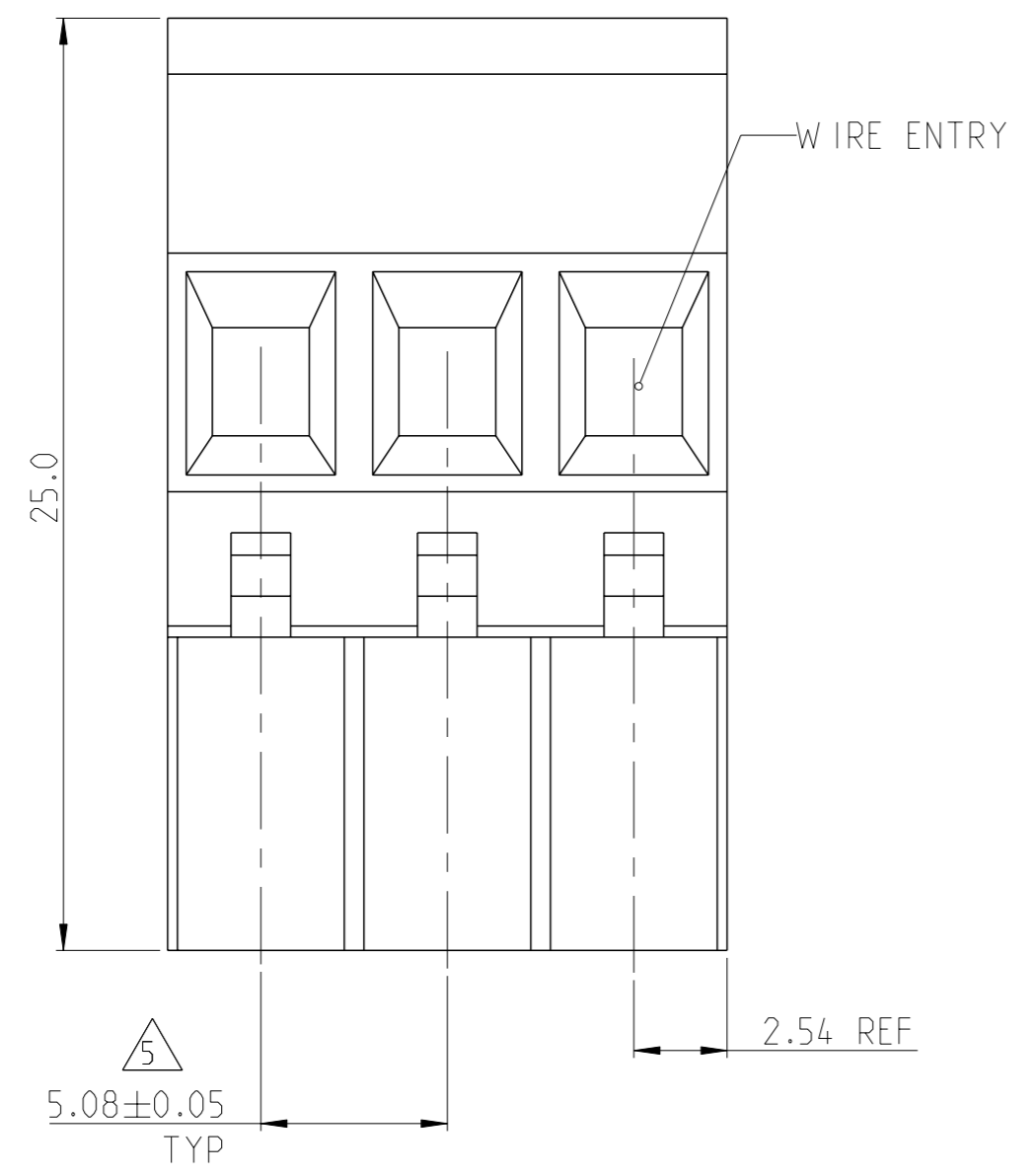

-3 AS SHOWN

DETAIL	DIM.	NO OF POS.	PART NUMBER
DETAIL J	40.64	8	3-284041-4
DETAIL H	20.32	4	3-284041-3
DETAIL G	30.48	6	3-284041-2
DETAIL F	30.48	6	3-284041-1
DETAIL E	40.64	8	3-284041-0
DETAIL D	20.32	4	2-284041-9
DETAIL C	20.32	4	2-284041-8
DETAIL B	20.32	4	2-284041-7
DETAIL A	20.32	4	2-284041-6
	127.00	25	2-284041-5
	121.92	24	2-284041-4
	116.84	23	2-284041-3
	111.76	22	2-284041-2
	106.68	21	2-284041-1
	101.60	20	2-284041-0
	96.52	19	1-284041-9
	91.44	18	1-284041-8
	86.36	17	1-284041-7
	81.28	16	1-284041-6
	76.20	15	1-284041-5
	71.12	14	1-284041-4
	66.04	13	1-284041-3
	60.96	12	1-284041-2
	55.88	11	1-284041-1
	50.80	10	1-284041-0
	45.72	9	284041-9
	40.64	8	284041-8
	35.56	7	284041-7
	30.48	6	284041-6
	25.40	5	284041-5
	20.32	4	284041-4
	15.24	3	284041-3
	10.16	2	284041-2

THIS DRAWING IS A CONTROLLED DOCUMENT. DIMENSIONS: mm. TOLERANCES UNLESS OTHERWISE SPECIFIED: 0 PLC ±, 1 PLC ±0.3, 2 PLC ±0.25, 3 PLC ±, 4 PLC ±, ANGLES ±, FINISH ±.

OWN: E. ZANOLINI, CHK: D. BIEVENOUR, APVD: D. BIEVENOUR. NAME: TERMINAL BLOCK, VERTICAL PLUG STACKING, LEFT HAND 5.08mm PITCH. SIZE: A1, CAGE CODE: 00779, DRAWING NO: 284041. WEIGHT: -. MATERIAL: -. FINISH: -. CUSTOMER DRAWING. SCALE: 4:1, SHEET 1 OF 2, REV: C6.

STE TE Connectivity

REVISIONS				
#	DATE	DESCRIPTION	DATE	APVD
-	-	SEE SHEET 1	-	-

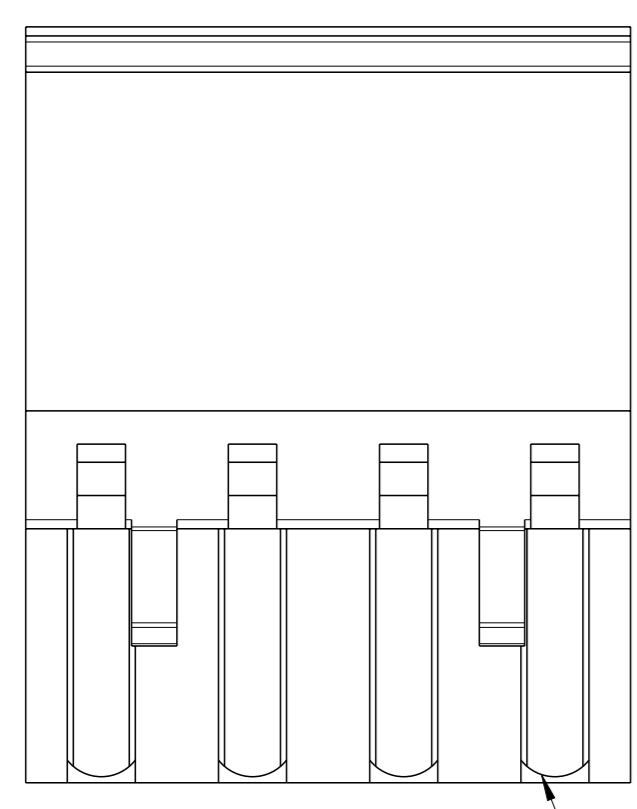

DETAIL A KEY

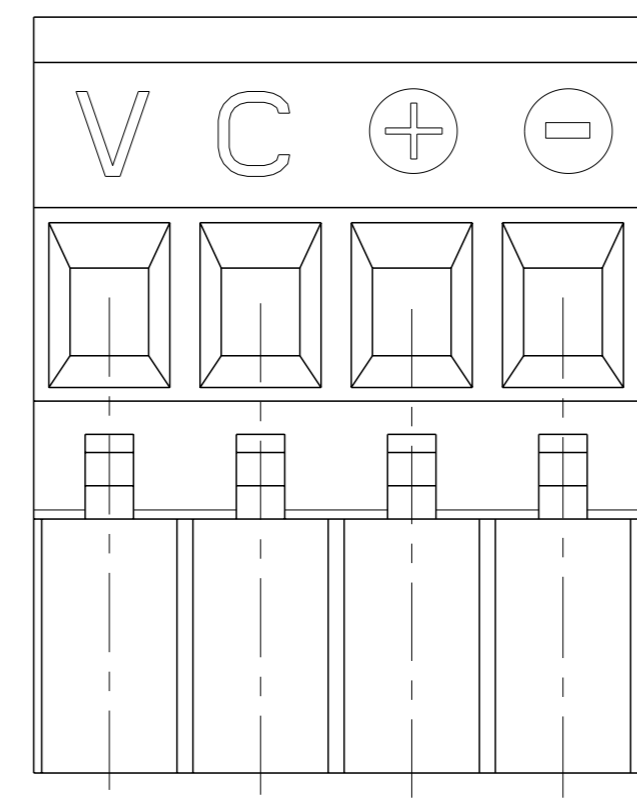

DETAIL B

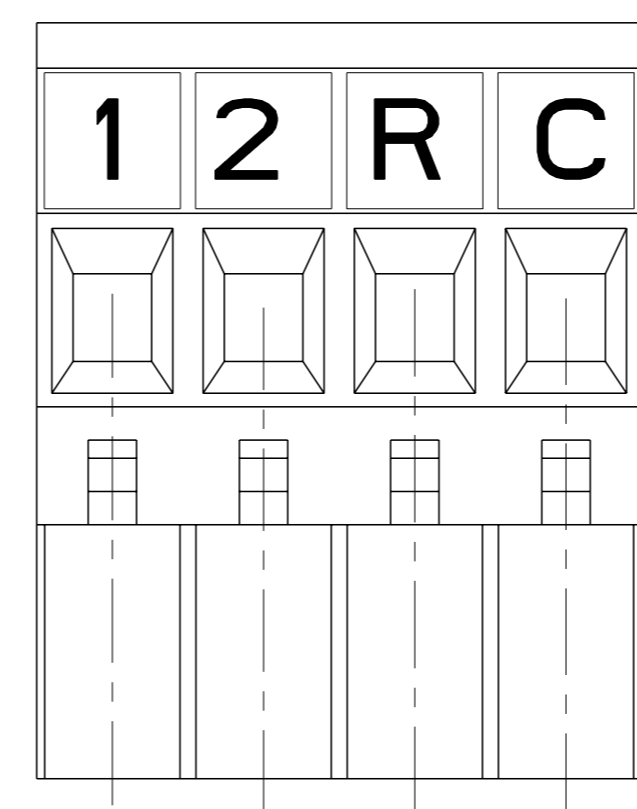

DETAIL C

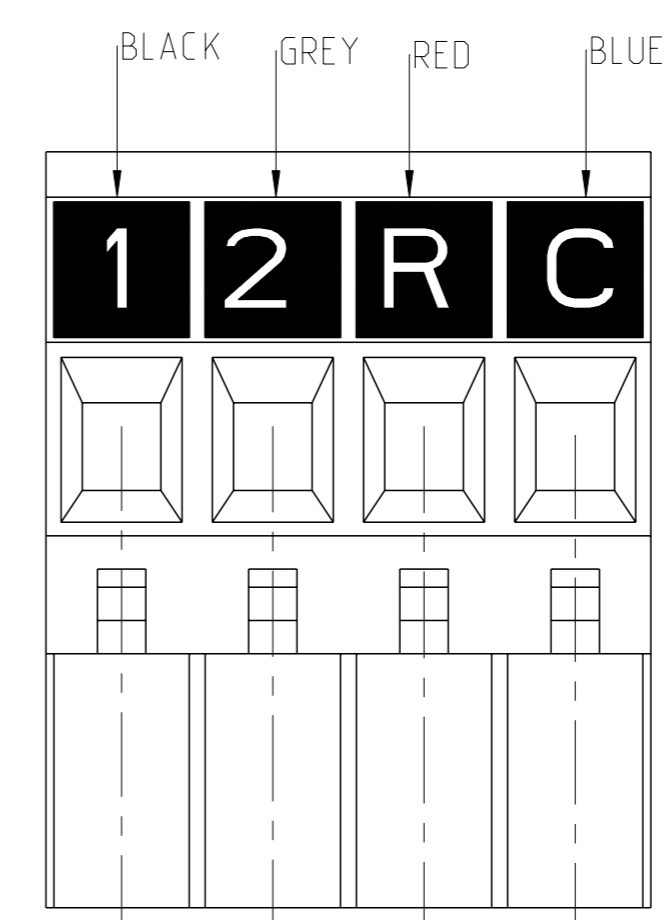

DETAIL D

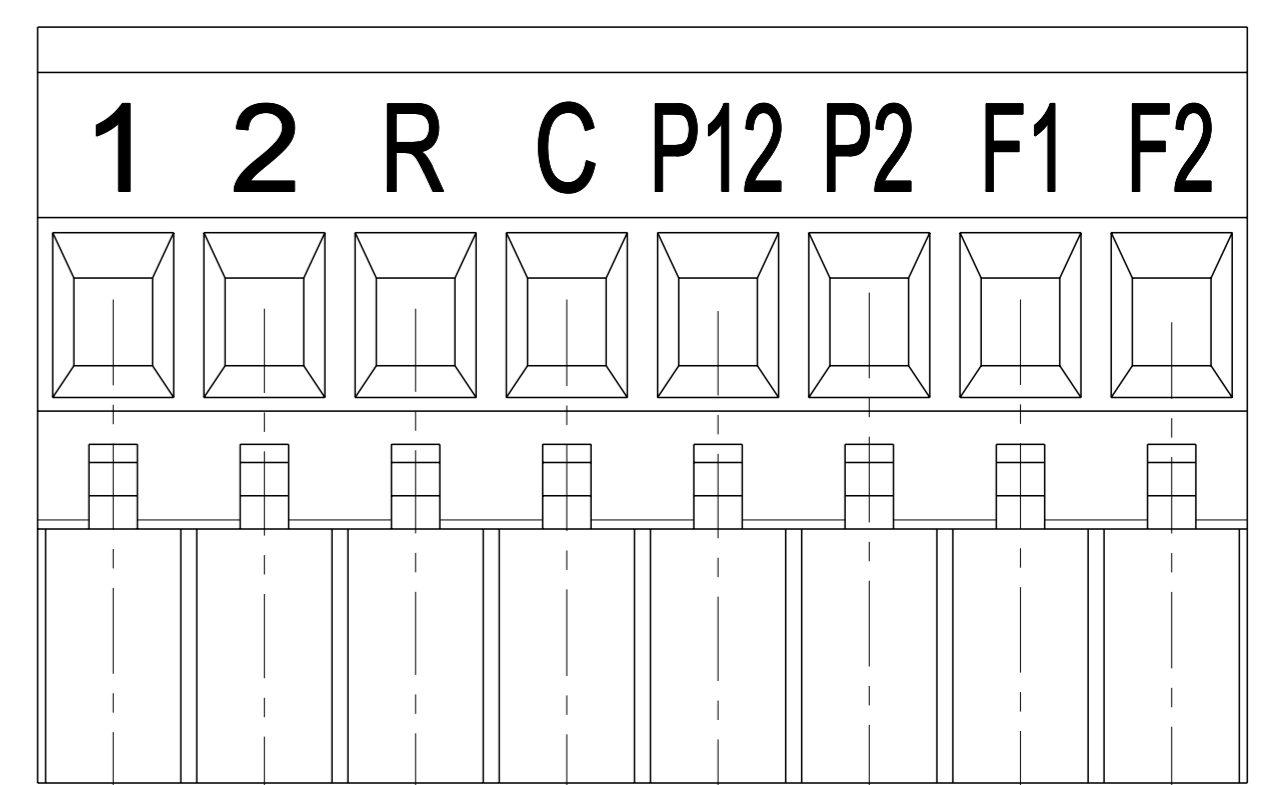

DETAIL E

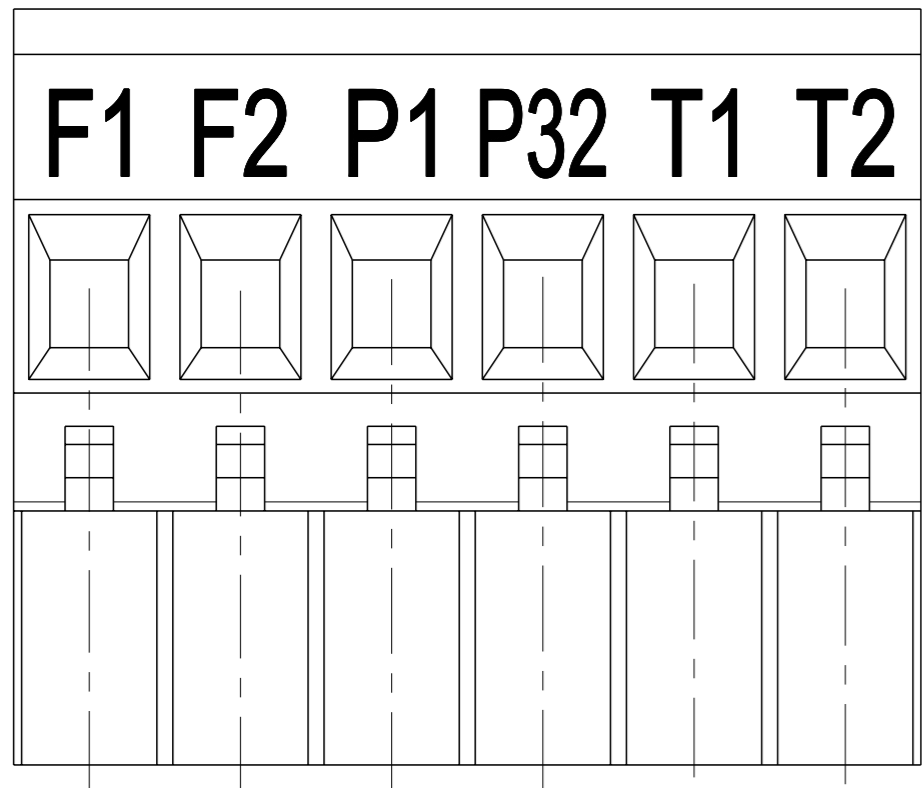

DETAIL F

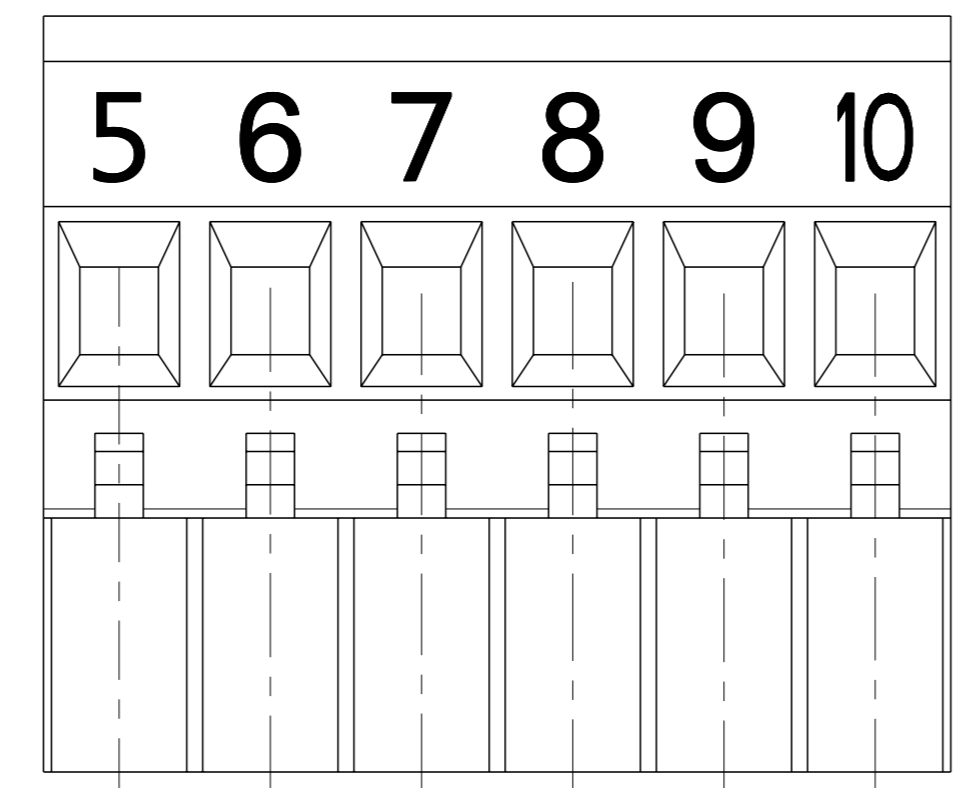

DETAIL G

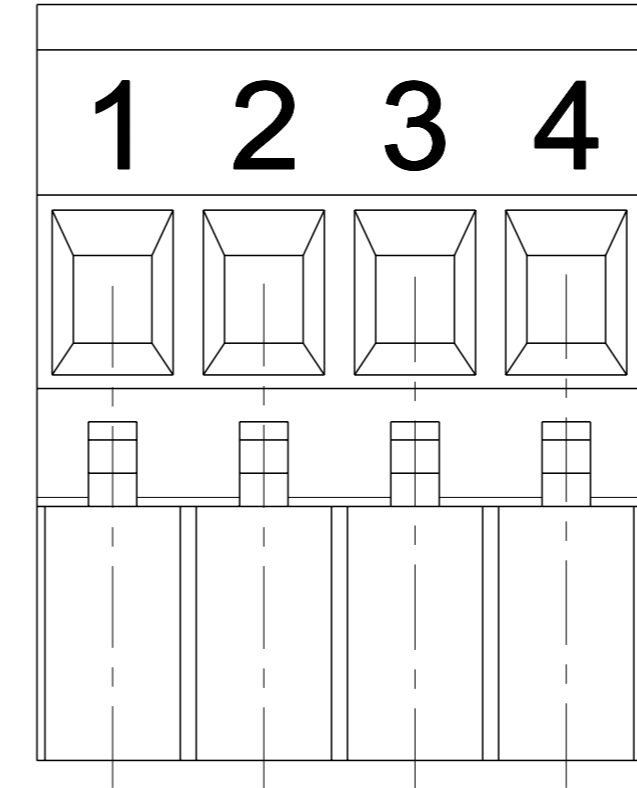

DETAIL H

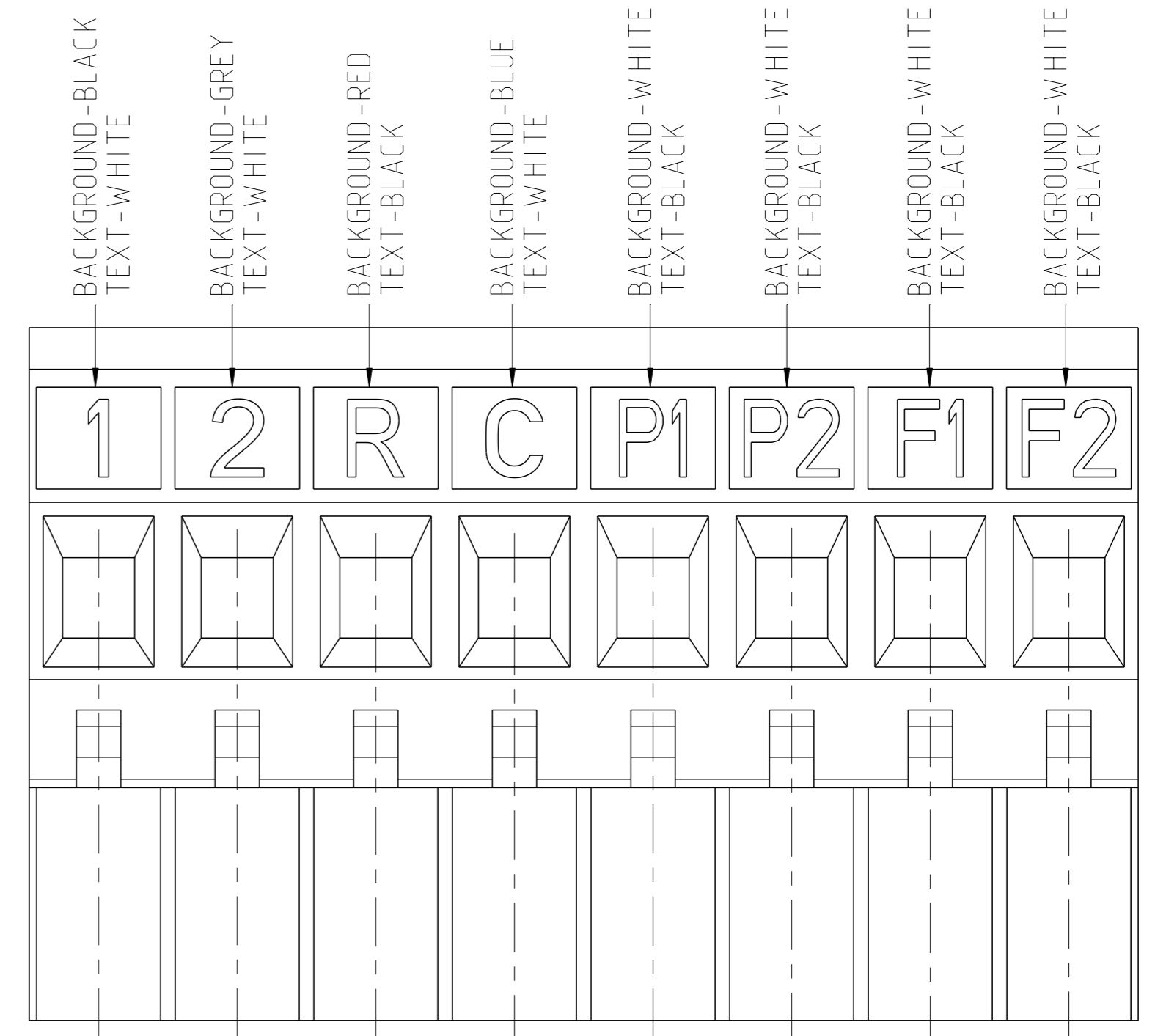

DETAIL J

THIS DRAWING IS A CONTROLLED DOCUMENT.		OWN E. ZANOLINI 27/MAR2001	 TE Connectivity
DIMENSIONS: mm		CHK D. BIEVENOUR 27/MAR2001	
TOLERANCES UNLESS OTHERWISE SPECIFIED: 0 PLC ±0.3 1 PLC ±0.25 2 PLC ±0.25 3 PLC ±0.25 4 PLC ±0.25 ANGLES ±0.2° FINISH		APVD D. BIEVENOUR 27/MAR2001	NAME TERMINAL BLOCK, VERTICAL PLUG STACKING, LEFT HAND 5.08mm PITCH
MATERIAL		APPLICATION SPEC	SIZE A1
CUSTOMER DRAWING		WEIGHT	CAGE CODE DRAWING NO. 00779 C=284041
SCALE 4:1		SHEET 2 OF 2	RESTRICTED TO

单击下面可查看定价，库存，交付和生命周期等信息

[>>TE Connectivity\(泰科\)](#)