

LOC	DIST	REVISIONS			
P	LTR	DESCRIPTION	DATE	DWN	APVD
AF	50	C1	10AUG2015	BDA	PKS
		ECR-15-005665			

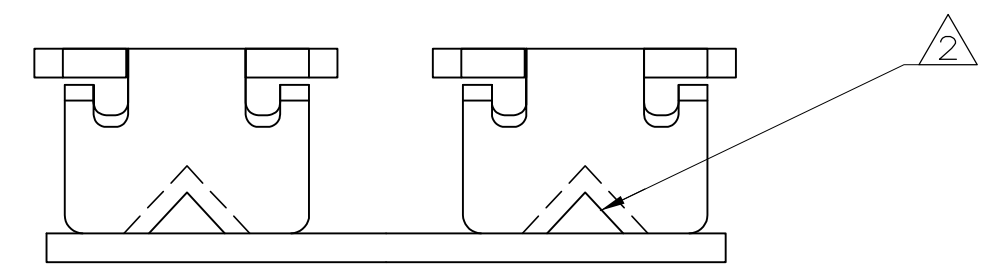

- ① SLOT ACCEPTS 0.36-0.57mm [#27-#23] AWG COPPER MAGNET WIRE.  
 SLOT ACCEPTS 0.51-0.64mm [#24-#22]AWG ALUMINUM MAGNET WIRE.  
 ALUMINUM WIRE RANGE APPLIES FOR POST-TIN PLATED VERSIONS ONLY. A SINGLE WIRE ONLY.
- ② POKE-IN ACCEPTS A 0.50-0.90mm<sup>2</sup> [#20-#18] AWG SOLID OR FUSED STRANDED LEAD WIRE.
- ③ RED COLORING ON THIS SURFACE TO PROVIDE CODING OF MAGNET WIRE RANGE.

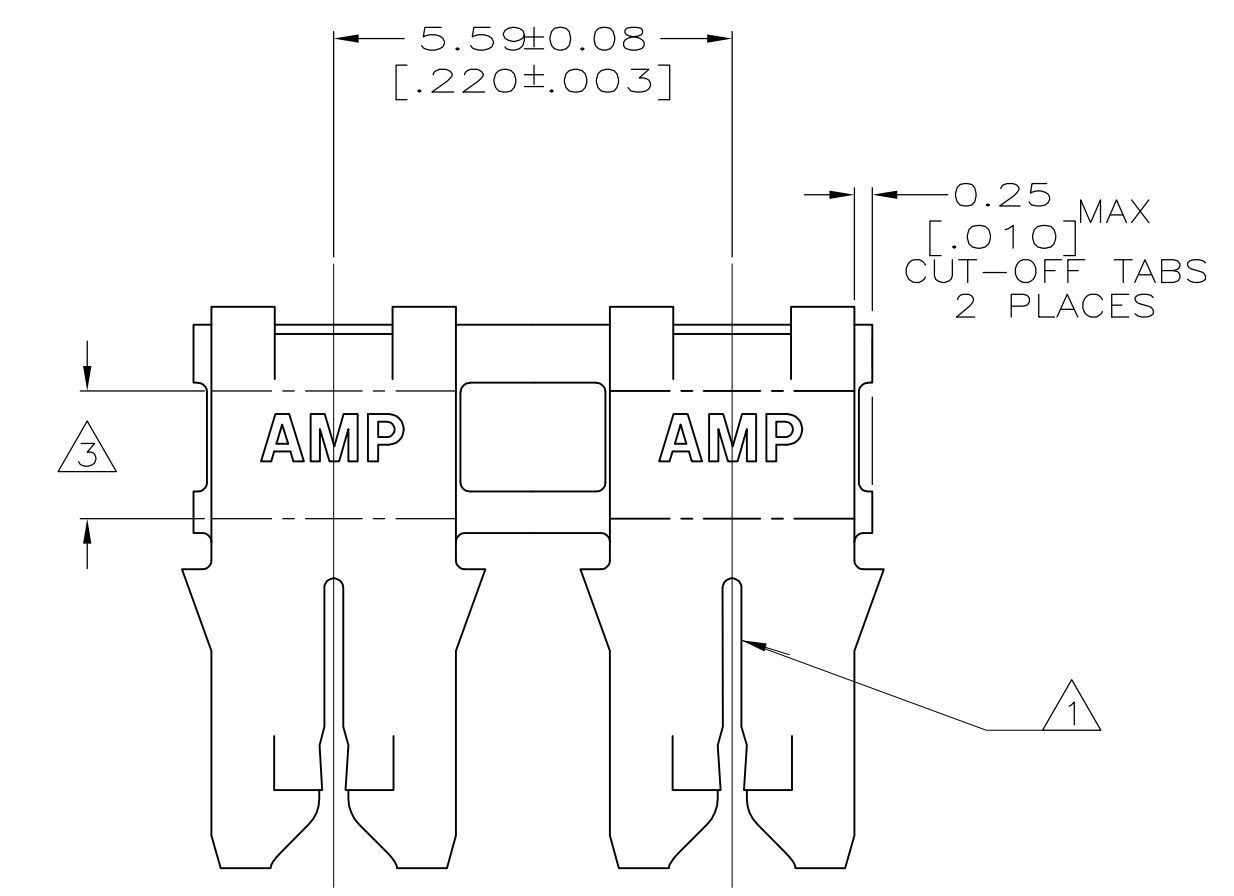
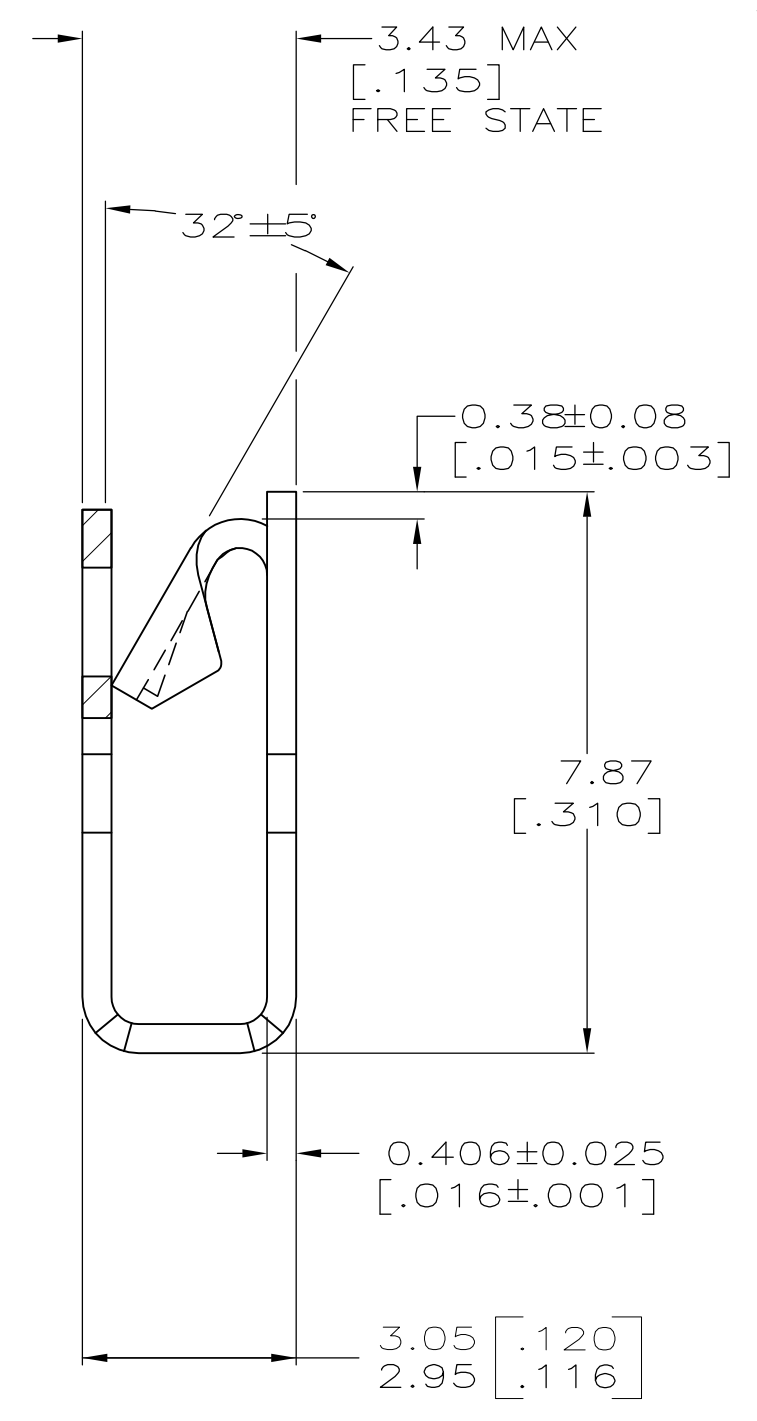
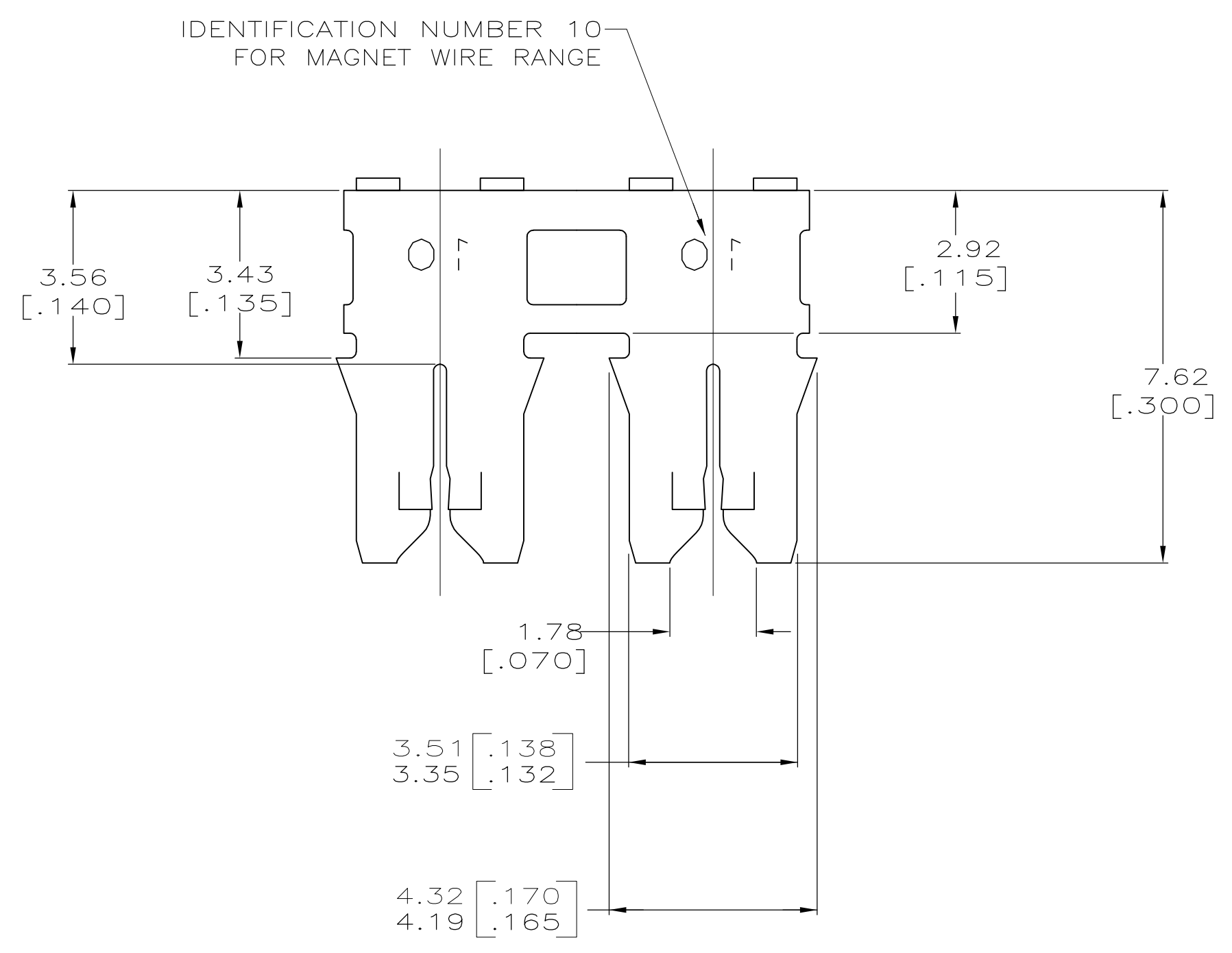

62842-1  
PART NUMBER

THIS DRAWING IS A CONTROLLED DOCUMENT.		DWN MICHAEL S. FEHER 26NOV96	TE connectivity
DIMENSIONS: mm [INCHES]		CHK RICHARD GRZYBOWSKI 26NOV96	
TOLERANCES UNLESS OTHERWISE SPECIFIED:		APVD NELSON E. NEFF 26NOV96	NAME
0 PLC ±-	1 PLC ±-	PRODUCT SPEC	108-2012
2 PLC ±0.25[.010]	3 PLC ±-	APPLICATION SPEC	114-2046
4 PLC ±-	ANGLES ±-	MATERIAL	4M BRASS
FINISH 0.002032[.000080] MIN TIN PER MIL-T-10727		WEIGHT	-
CUSTOMER DRAWING		SCALE	10:1
SHEET		1	OF 1
REV		C1	

单击下面可查看定价，库存，交付和生命周期等信息

[>>TE Connectivity\(泰科\)](#)