

THIS DRAWING IS UNPUBLISHED. RELEASED FOR PUBLICATION 20
 © COPYRIGHT 20 BY - ALL RIGHTS RESERVED.

LOC	DIST	REVISIONS					
AP	-	P	LTR	DESCRIPTION	DATE	DWN	APVD
		E		REVISED DESIGN ECO-13-008769	01AUG2013	NCL	MLO

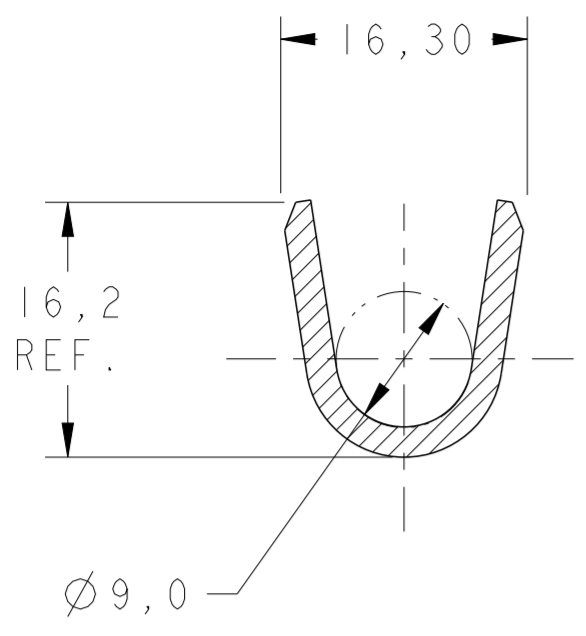

SECTION A-A
SCALE 2:1

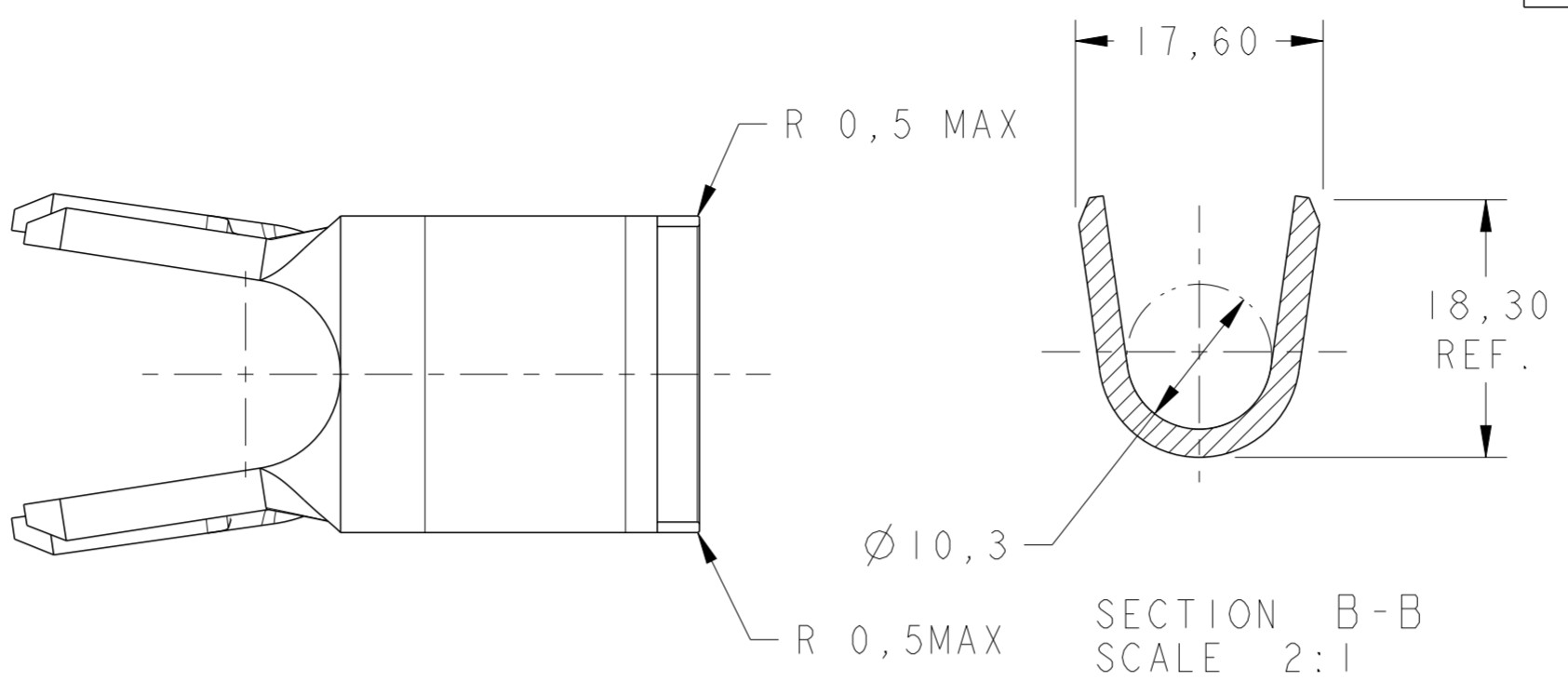

SECTION B-B
SCALE 2:1

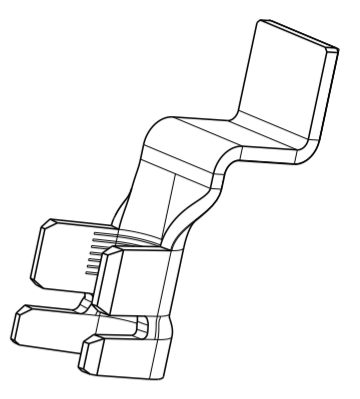

PERSPECTIVE VIEW
SCALE 1:1

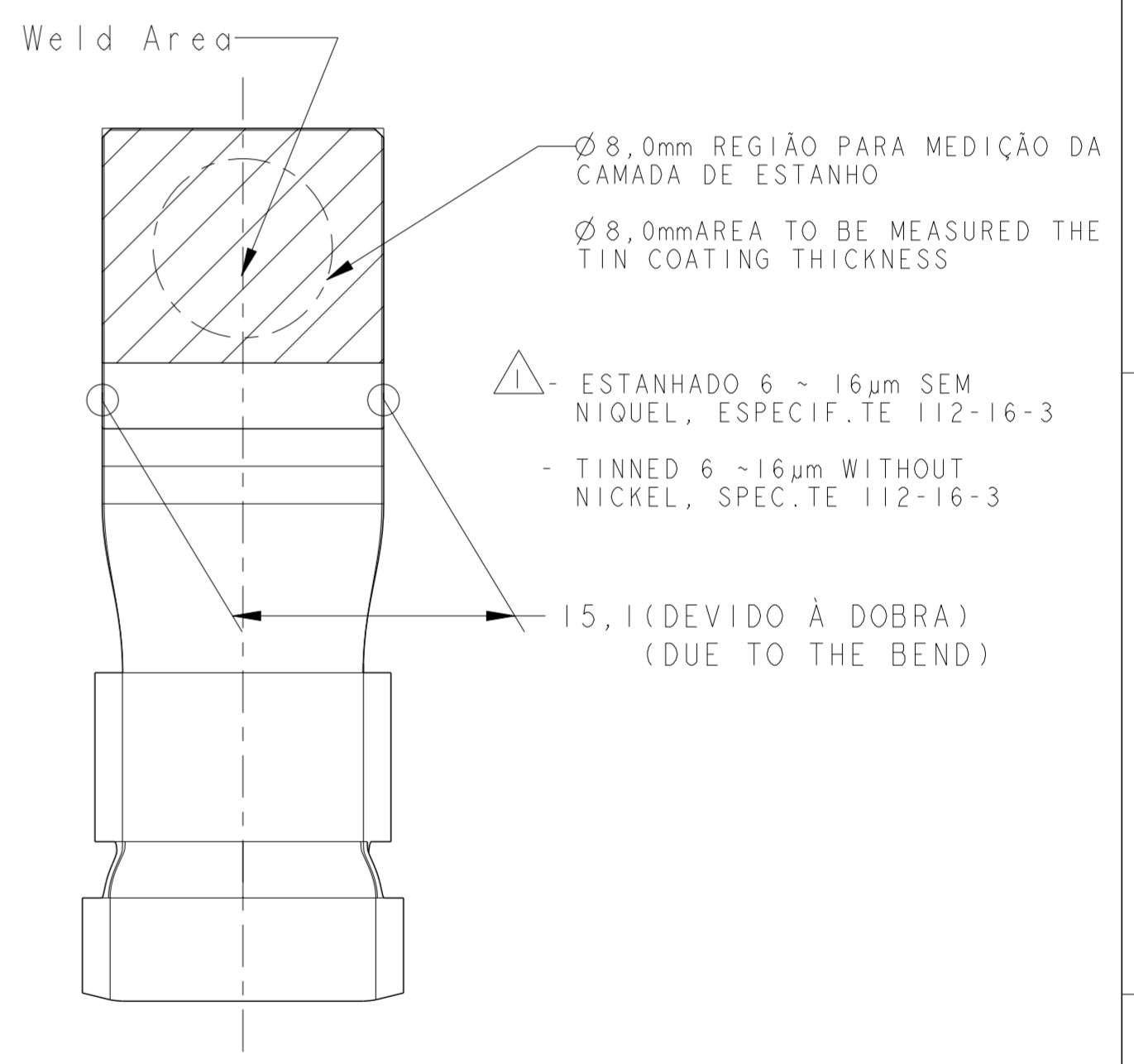
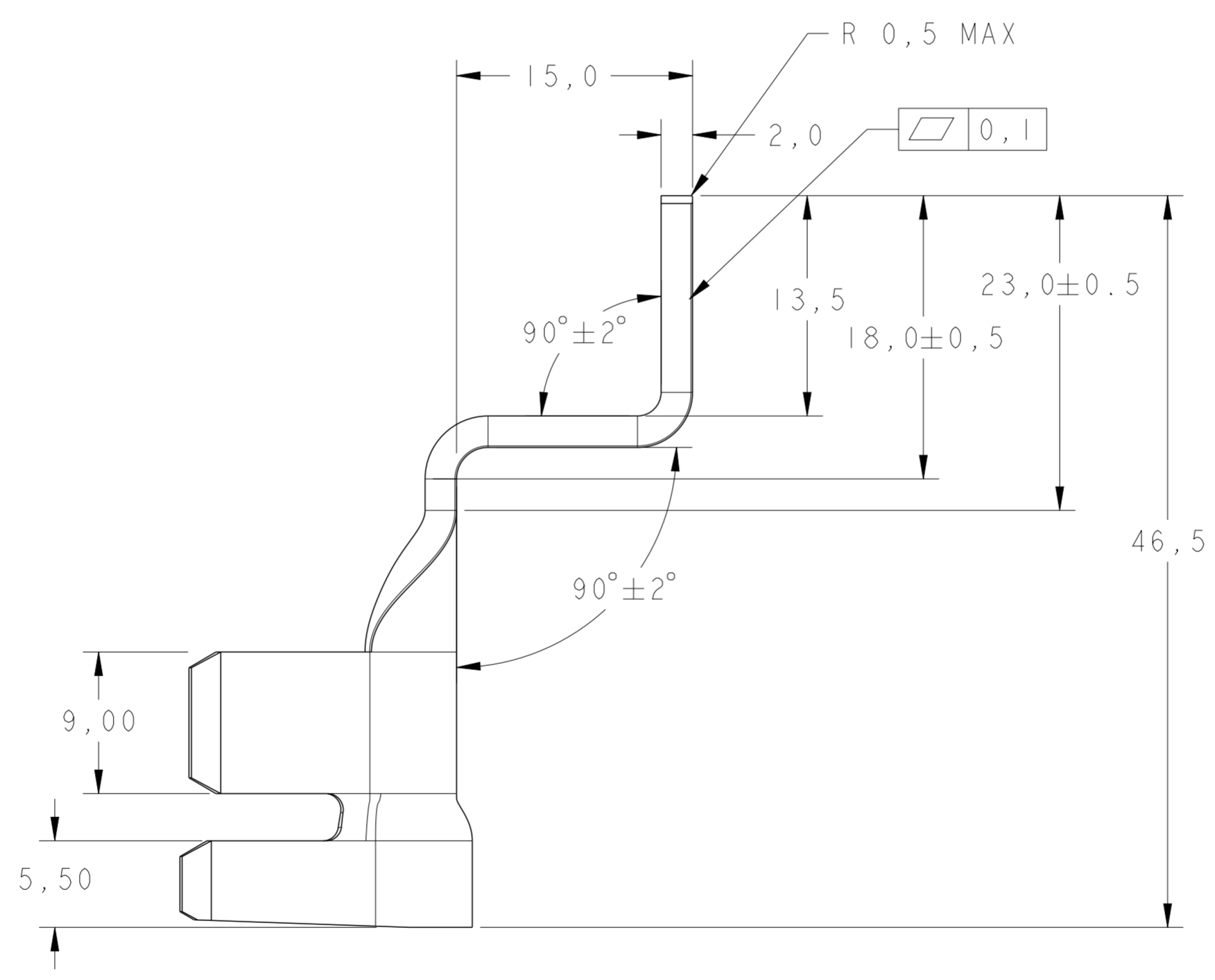
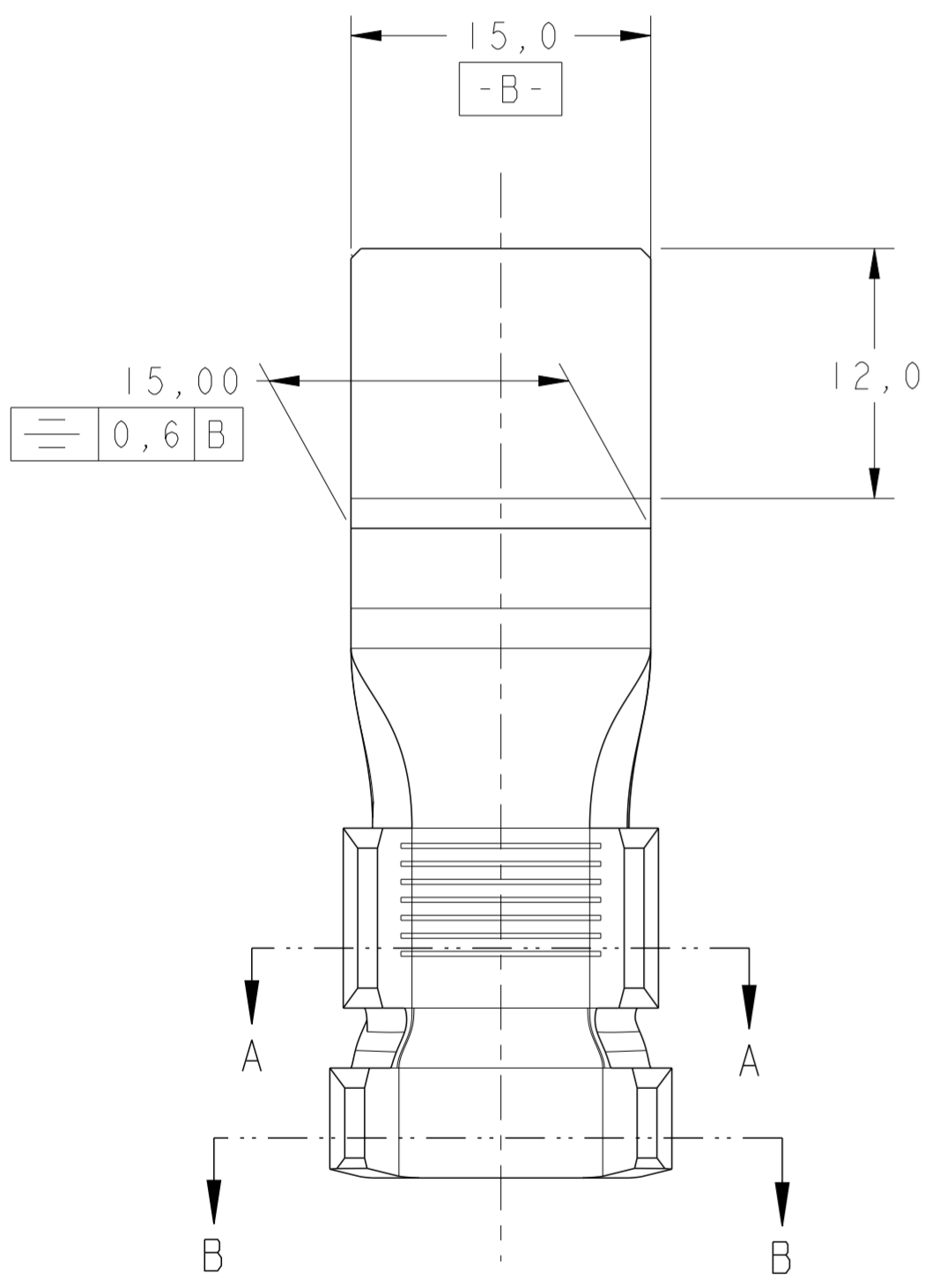

25 - 37 mm ²	ESTANHADO/TINNED Δ 1	LATÃO/BRASS	1599921-1
WIRE RANGE	FINISH	MATERIAL	PART NUMBER
THIS DRAWING IS A CONTROLLED DOCUMENT.		TE Connectivity	
DIMENSIONS: mm TOLERANCES UNLESS OTHERWISE SPECIFIED: 0 PLC ± 1 PLC ±0.3 2 PLC ± 3 PLC ± 4 PLC ± ANGLES ±° FINISH		NAME: - PRODUCT SPEC: - APPLICATION SPEC: - WEIGHT: - CUSTOMER DRAWING	
SEE TABLE		SEE TABLE	
MATERIAL		RESTRICTED TO	
DWN: E. J. G. SILVA 20 JUN 2006 CHK: P. L. FARIA 20 JUN 2006 APVD: D. OLIVEIRA 20 JUN 2006		SIZE: A2 CAGE CODE: - DRAWING NO: C-1599921 SCALE: 3:1 SHEET: 1 OF 1 REV: E	



单击下面可查看定价，库存，交付和生命周期等信息

[>>TE Connectivity\(泰科\)](#)