



NOTE

All numerical values are in metric units [with U.S. customary units in brackets]. Dimensions are in millimeters [and inches]. Unless otherwise specified, dimensions have a tolerance of ± 0.13 [$\pm .005$] and angles have a tolerance of $\pm 2^\circ$. Figures and illustrations are for identification only and are not drawn to scale.

1. INTRODUCTION

This specification covers the requirements for application of MAG-MATE Mini Series Terminals. These terminals are insulation piercing and are designed to accept a wire size range of 52 through 30 AWG solid round copper magnet wire with single or heavy insulation. There are six locking barbs on each terminal to ensure retention in your housing.

Several terminal interfaces are available; Lead Wire Poke-In, Solder Tab, Wire Crimp Barrel, and FASTON* Tabs of 4.75 x 0.51 mm and 2.79 x 0.51 mm [.187 x .020 in. and .110 x .020 in.] sizes. See Figure 1. These terminals may be applied by hand or by automatic machine application tooling.

When corresponding with TE Connectivity Personnel, use the terminology provided in this specification to facilitate your inquiries for information. Basic terms and features of this product are provided in Figure 1.

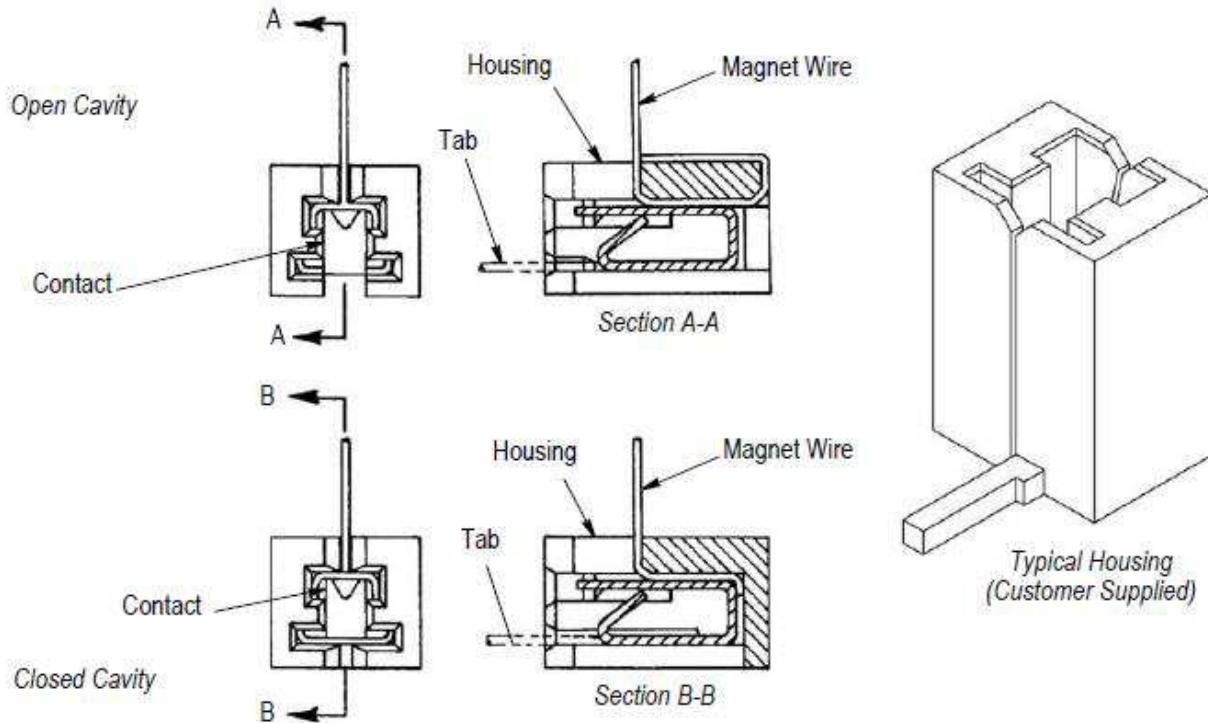

MAG-MATE Mini Terminals

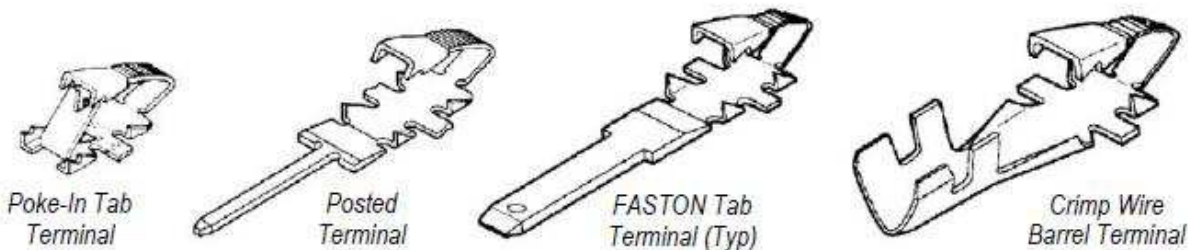

Figure 1

2. REFERENCE MATERIAL

2.1. Revision Summary

- Updated document to corporate requirements.
- Added Paragraph 3.2.A and 3.2.B.

2.2. Customer Assistance

Reference Product Base Part Number 62606 and Product Code 1039 are representative of MAG-MATE Mini Series Terminals. Use of these numbers will identify the product line and help you to obtain product and tooling information when visiting www.te.com or calling the number at the bottom of page 1.

2.3. Drawings

Customer drawings for product part numbers are available from www.te.com. Information contained in the customer drawing takes priority.

2.4. Specifications

Product Specification [108-2016](#) provides product performance and test results.

2.5. Instructional Material

Instruction sheets (408-series) provide product assembly instructions or tooling setup and operation procedures and customer manuals (409-series) provide machine setup and operating procedures. Instructional material that pertain to this product are:

- [408-3295](#) Preparing Reel of Contacts for Application Tooling
- [408-6734](#) Insertion Tool 274287-2 and 274290-2 for Mini MAG-MATE Terminals
- [408-9816](#) Handling of Reeled Products
- [409-5128](#) Basic AMP-O-LECTRIC* Model "K" Terminating Machines
- [410-5483](#) MAG-MATE Interconnect System

3. REQUIREMENTS

3.1. Safety

Do not stack product shipping containers so high that the containers buckle or deform.

3.2. Storage

A. Storage Temperature and Humidity

Products should be stored at room temperature and low ambient humidity. The temperature and humidity should be in the range as per DIN IEC68 (15-35°C, 25-75% relative humidity). Products should not be exposed to extreme temperatures, intense humidity or damaging mediums (acid or base atmospheres, aggressive agents, etc.)

B. Durability of Products

These products have a normally unlimited durability, provided they are stored in their original packing and at normal storage temperature and humidity. Exceptions are solderable products, tubes and cables. Solderable products will be solderable only within 6 months after delivery

C. Ultraviolet Light

Prolonged exposure to ultraviolet light may deteriorate the chemical composition used in the product material.

D. Shelf Life

The product should remain in the shipping containers until ready for use to prevent deformation to components. The product should be used on a first in, first out basis to avoid storage contamination that could adversely affect performance.

E. Chemical Exposure

Do not store product near any chemical listed below as they may cause stress corrosion cracking in the material.

Alkalies	Ammonia	Citrates	Phosphates	Citrates	Sulfur Compounds
Amines	Carbonates	Nitrites	Sulfur Nitrites		Tartrates



NOTE

Where the above environmental conditions exist, phosphor-bronze contacts are recommended instead of brass if available.

3.3. Cavity Design

Optional open and closed cavity designs that will accept MAG-MATE Mini Series Terminals shall be in accordance with the design requirements specified in Paragraph 3.3.A and 3.3.B. Pre-design consultation with TE Engineering is necessary to be sure the cavity configuration will be functional and that it will be compatible with automatic insertion machines.

A. Open Cavity

Open cavity design shall meet the requirements specified in Figure 2 for tab and post interface types and Figure 3 for poke-in lead wire type.

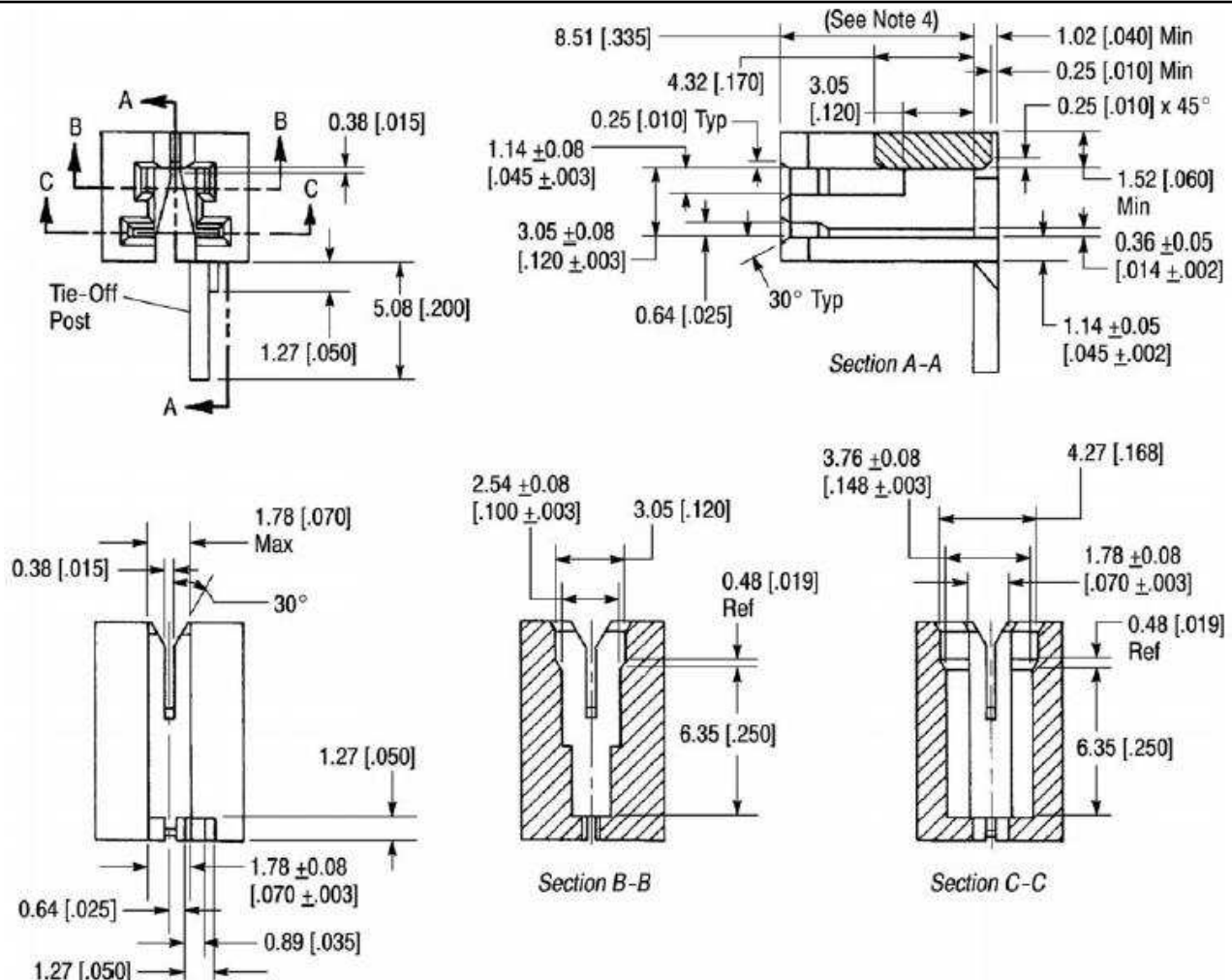
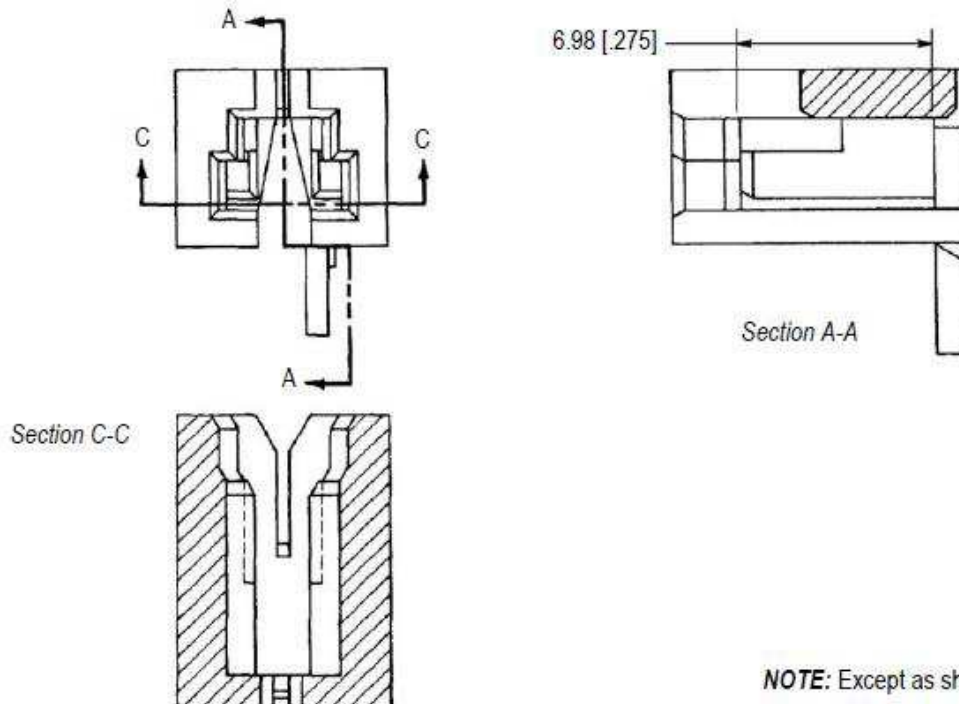

Figure 2

i
NOTE

The following notes apply to the housings shown in Figure 2, Figure 3, Figure 4, and Figure 5:

- (1) Housing material shall be 6/6 nylon, 30% minimum glass filled.
- (2) If poke-in type terminals are used, a means of providing a strain relief to the lead wire is required.
- (3) Consideration shall be given for start and finish winding to prevent magnet wire crossover.
- (4) Dimension may be reduced to a minimum of 7.37 mm [.290 in.] if required.

Figure 3
B. Closed Cavity

Closed cavity design shall meet the requirements specified in Figure 4 for tab and post interface types and Figure 5 for poke-in lead wire type.

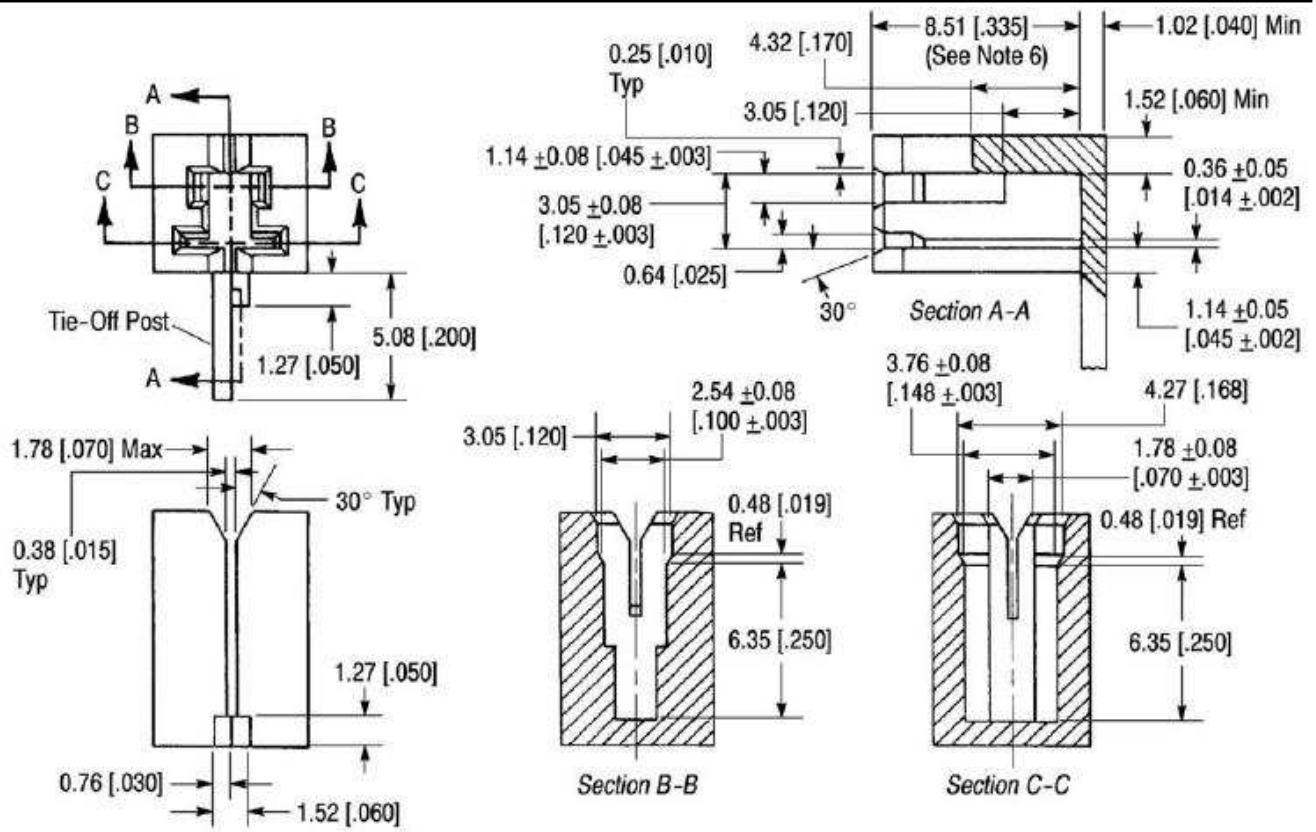

Figure 4

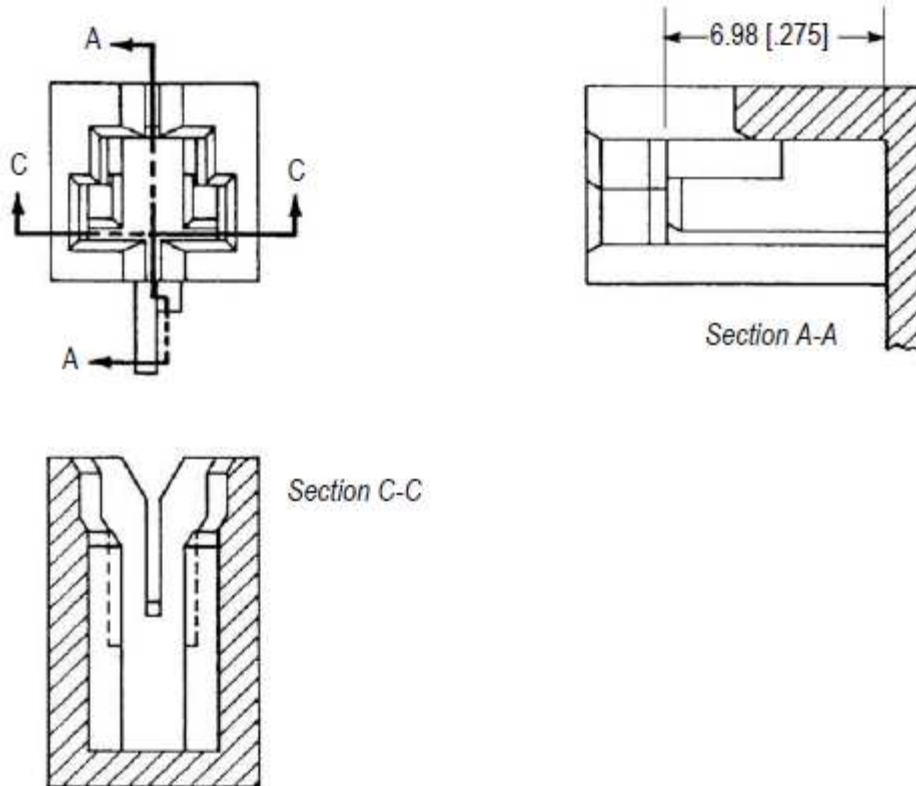
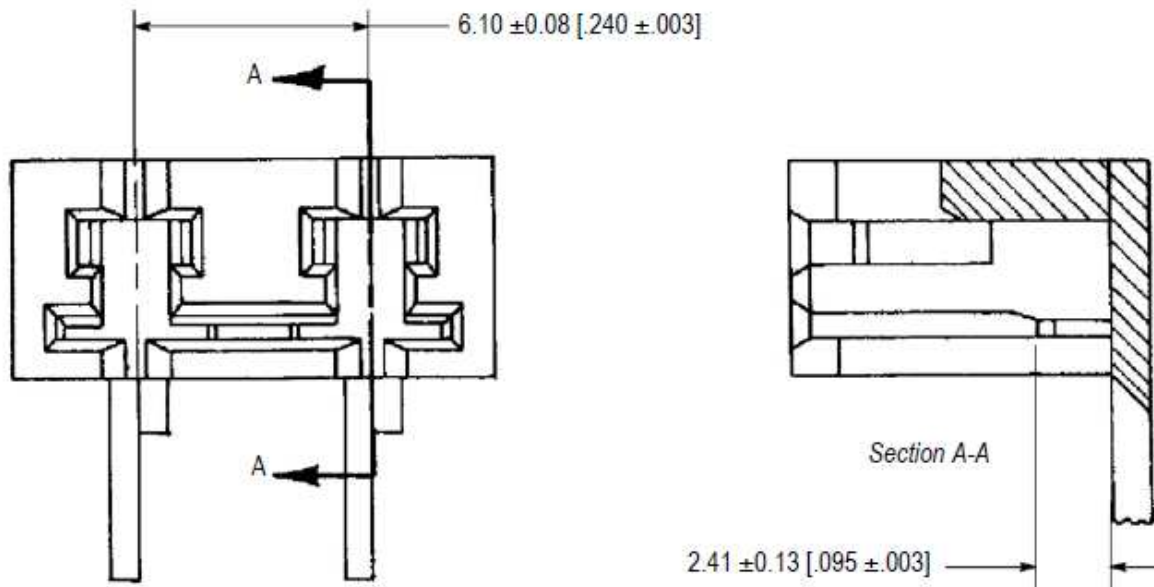

Figure 5

C. Commoned Closed Cavities

Closed cavity design specified in Figure 4 and Figure 5 may be commoned in accordance with the requirements specified in Figure 6 to produce a commoned closed cavity.



NOTE: Commoned cavities otherwise same as in Figures 4 or 5.

Figure 6

3.4. Lead Wire

The lead wire shall have a wire size range of 18-22 AWG solid or prefused stranded wire with a maximum outside insulation diameter of 2.79 mm [.110 in.], and shall have a strip length of 6.35 ± 0.38 mm [$.250 \pm 0.015$ in.].



CAUTION

Do NOT pick up or carry assembled units by the poke-in lead wires. This can over-stress or damage the poke-in interface connection. Strain relief is recommended for poke-in lead wires.

3.5. Magnet Wire Placement

A. Open Cavity

Magnet wire shall be wrapped around the open cavity housing and the free end shall then be laced and wrapped a minimum of three times around the tie-off post as indicated in Figure 7.

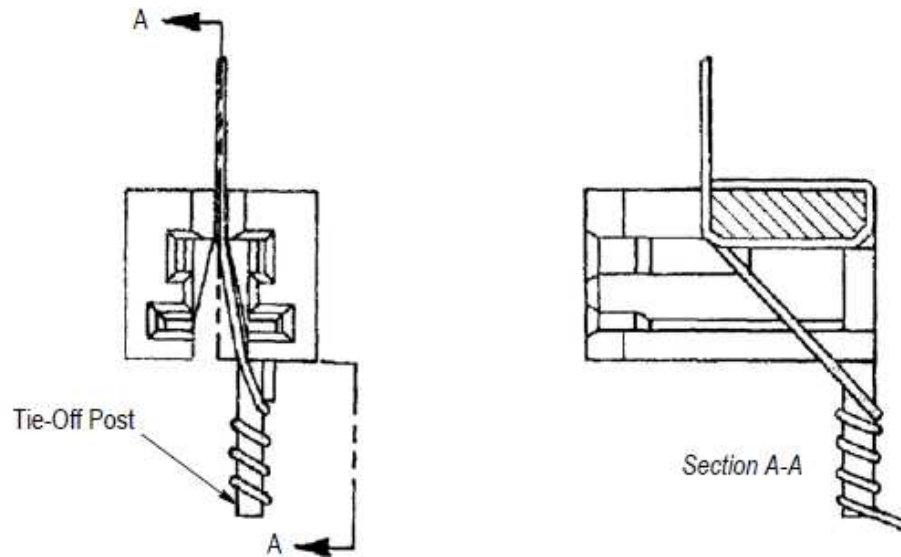

Figure 7

B. Closed Cavity

The magnet wire shall be laced across the closed cavity slots and the free end shall be wrapped a minimum of three times around the tie-off post as indicated in Figure 8.

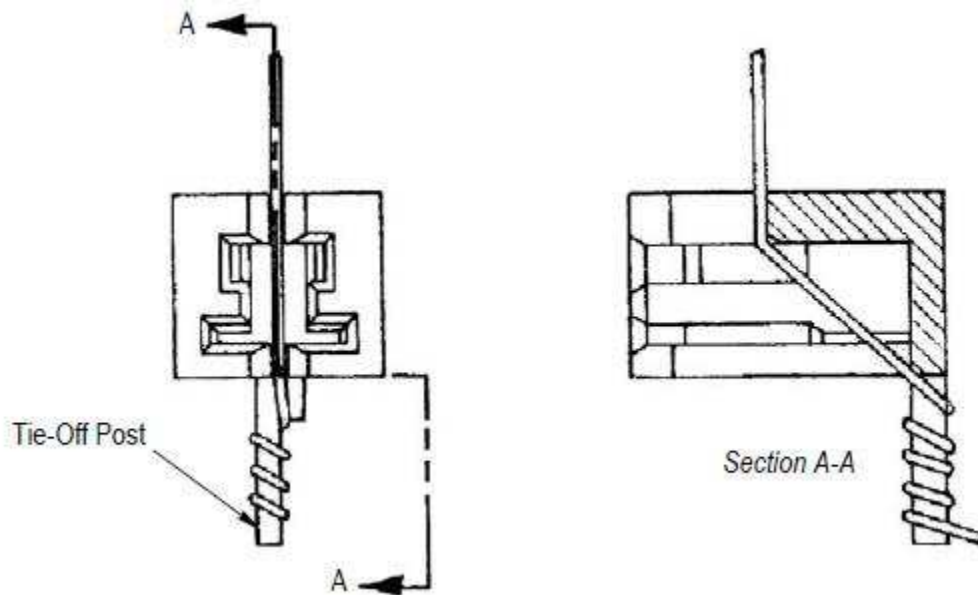

Figure 8

3.6. Terminal Insertion

A. Open Cavity

The terminal shall be inserted in the open cavity housings as shown in Figure 9.

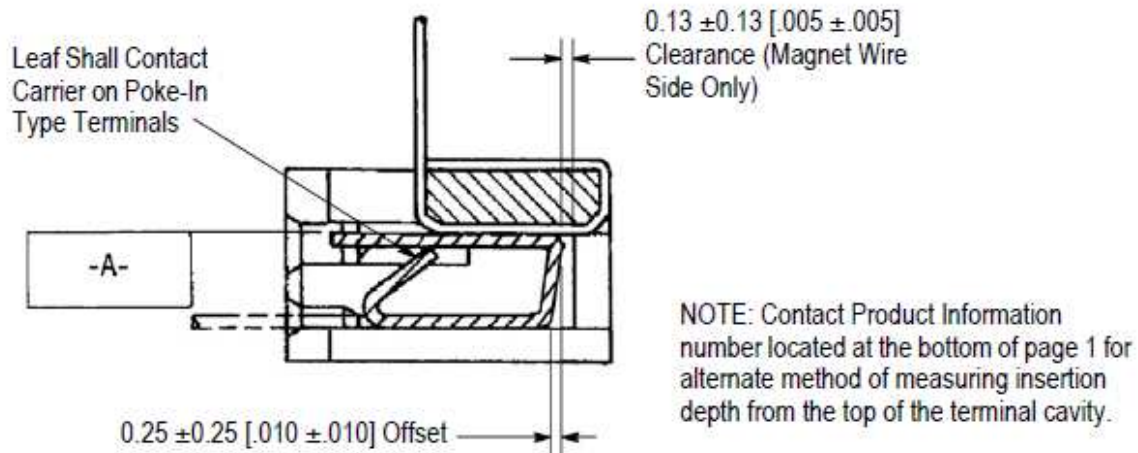

Figure 9

B. Closed Cavity

The terminal shall be inserted in the closed cavity housings as shown in Figure 10.

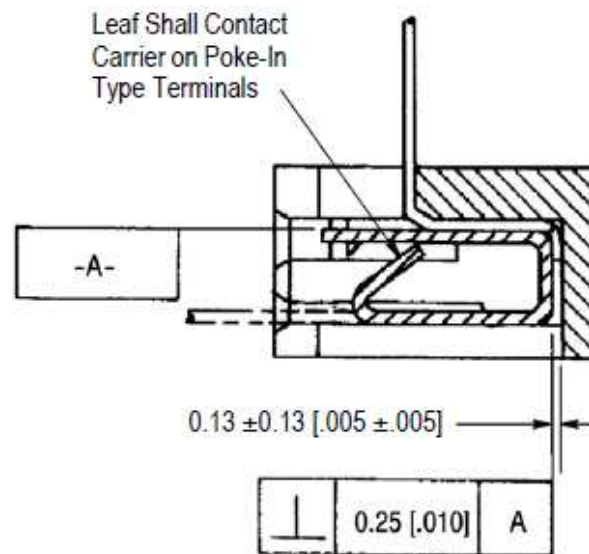

Figure 10

3.7. Magnet Wire Location

The magnet wire shall be located within the center half of the terminal serrations after inserting the terminals into the housing cavity.

3.8. Terminal Cutoff Tab and Burr

A. Cutoff Tab

The terminal cutoff tab shall be within the limits as specified in Figure 11.

B. Burr

The burrs on the cutoff tabs shall not exceed 0.08 mm [.003 in.].

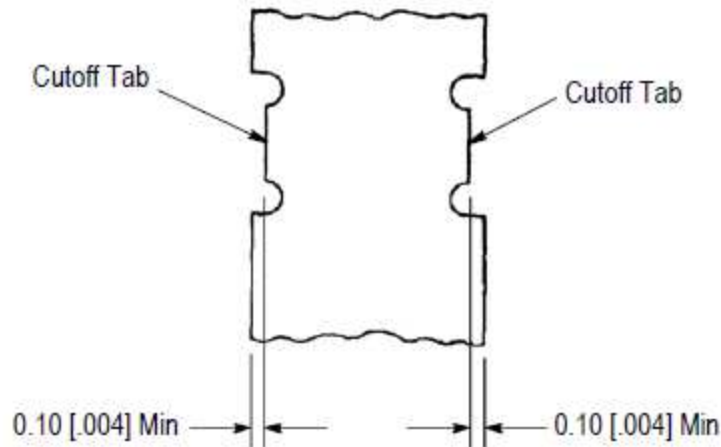

INTERFACE TYPE	MAGNET WIRE SIZE	NUMBER OF WIRE WRAPS‡
POKE-IN LEAD WIRE	30-32	1
	33-36	2
	36	2
	37-38	3
	37-44	3
4.75 x 0.51 mm [.187 x .020 in.]	30-32	1
	33-36	2
	37-38	3
1.78 x 0.51 mm [.070 x .020 in.]	30-32	1
	33-36	2
	37-38	3

‡ Recommended number of wraps on open cavity design only.

Figure 11

4. QUALIFICATION

4.1. Underwriters Laboratories Inc. (UL)

MAG-MATE Mini Series Terminals are Recognized under the Component Recognition Program of Underwriters Laboratories Inc. (UL) in File Number E13288.

5. TOOLING

A variety of insertion tooling and automatic machines are available for your production needs. Some tooling is shown in Figure 12. Contact the Product Information Center number located at the bottom of page 1 for your specific requirements.

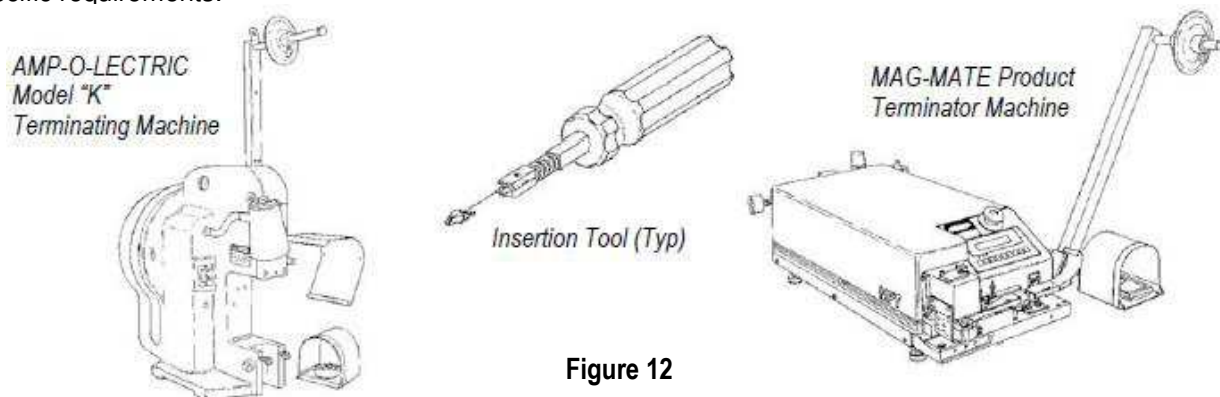

Figure 12

6. VISUAL AID

The illustration below shows a typical application of this product. This illustration should be used by production personnel to ensure a correctly applied product. Applications which do not appear correct should be inspected using the information in the preceding pages of this specification and in the instructional material shipped with the product or tooling.

HOUSING MUST NOT BE SCRAPPED, CRACKED, BROKEN, OR HAVE ANY OTHER SIGNS OF DAMAGE

WIRE SHOULD HAVE SUFFICIENT SLACK TO ALLOW ANY NECESSARY MOVEMENT WITHOUT STRETCHING THE WIRE

WIRE TRIM SUPPORT SHOULD BE REMOVED

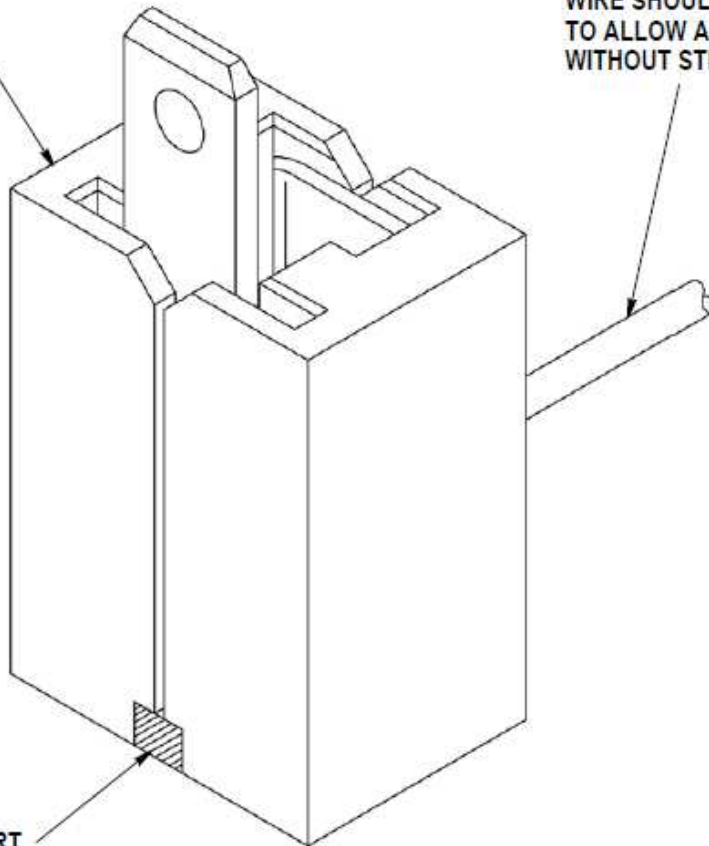

Figure 13: Visual Aid

单击下面可查看定价，库存，交付和生命周期等信息

[>>TE Connectivity\(泰科\)](#)