

LOC		DIST		REVISIONS			
CM	00	REV	DATE	BY	CHK	APP	REV
D		REVISED PER ECO-12-016930	05OCT12	KH	SM		

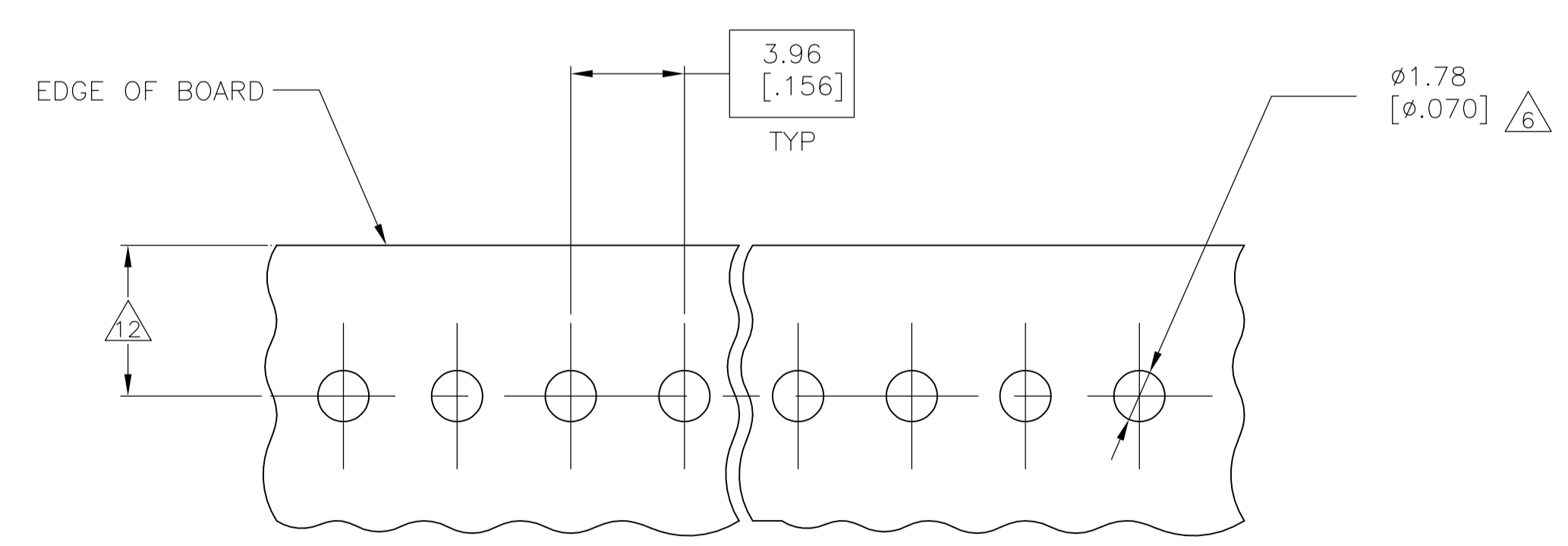
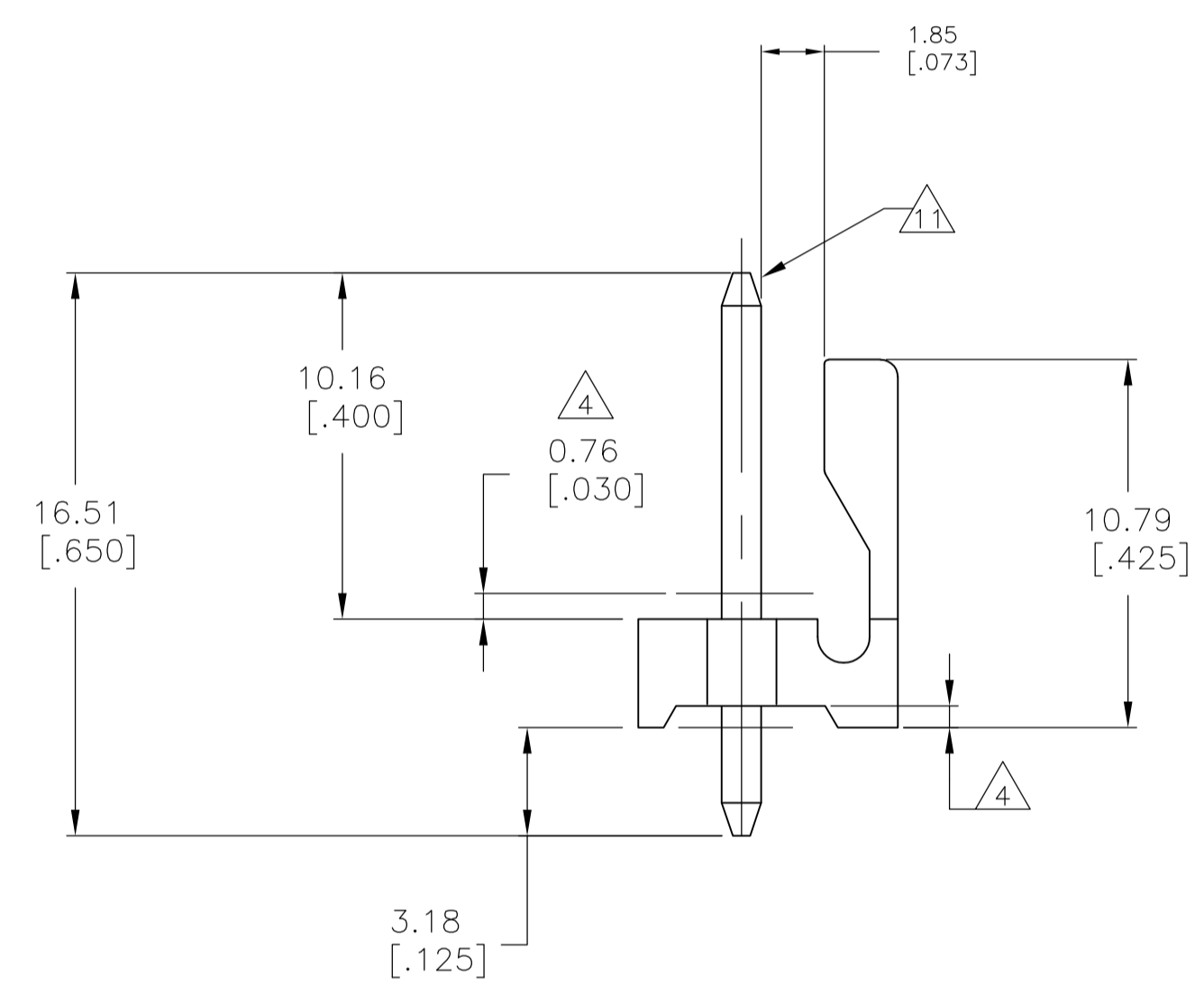
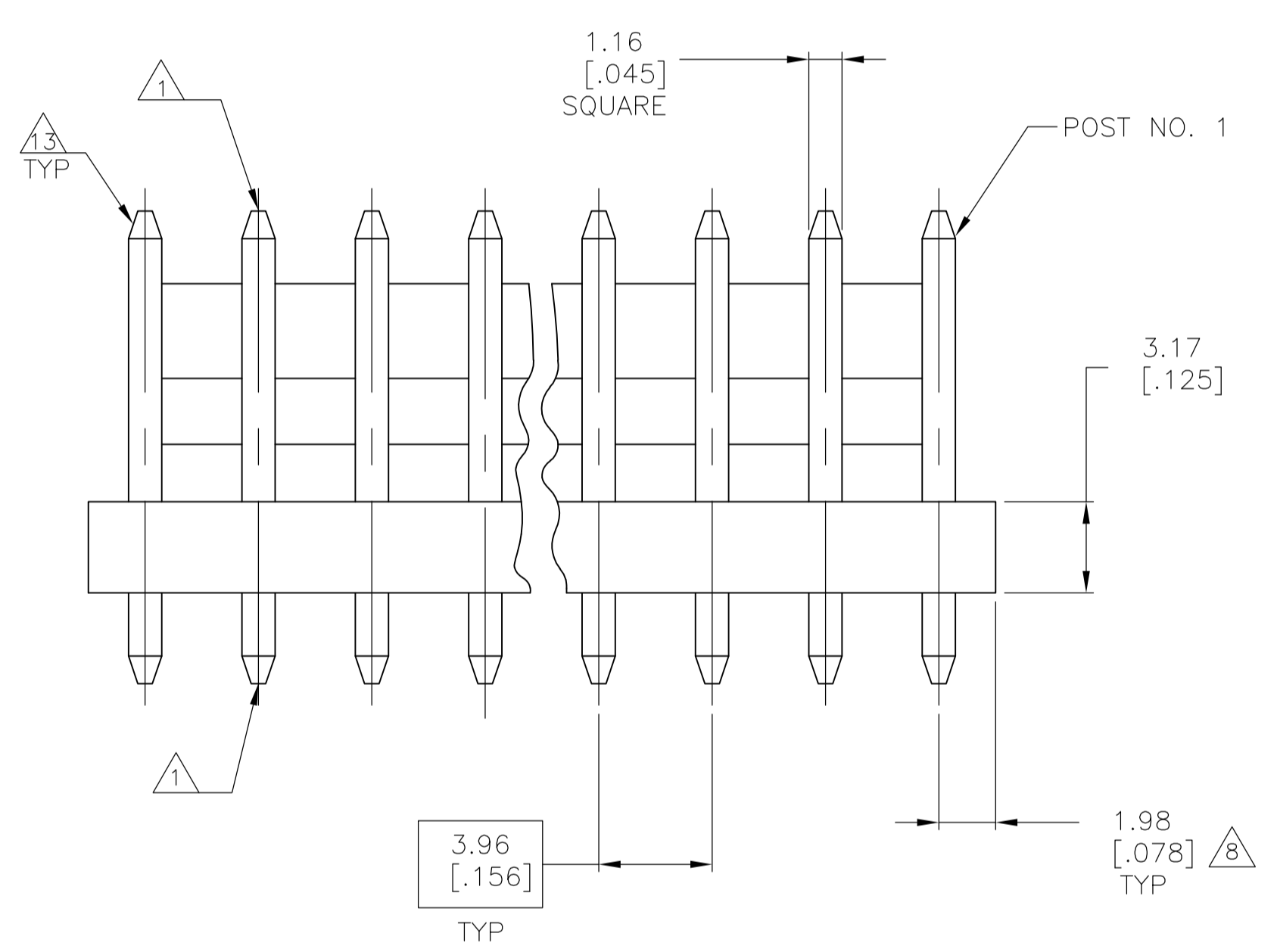
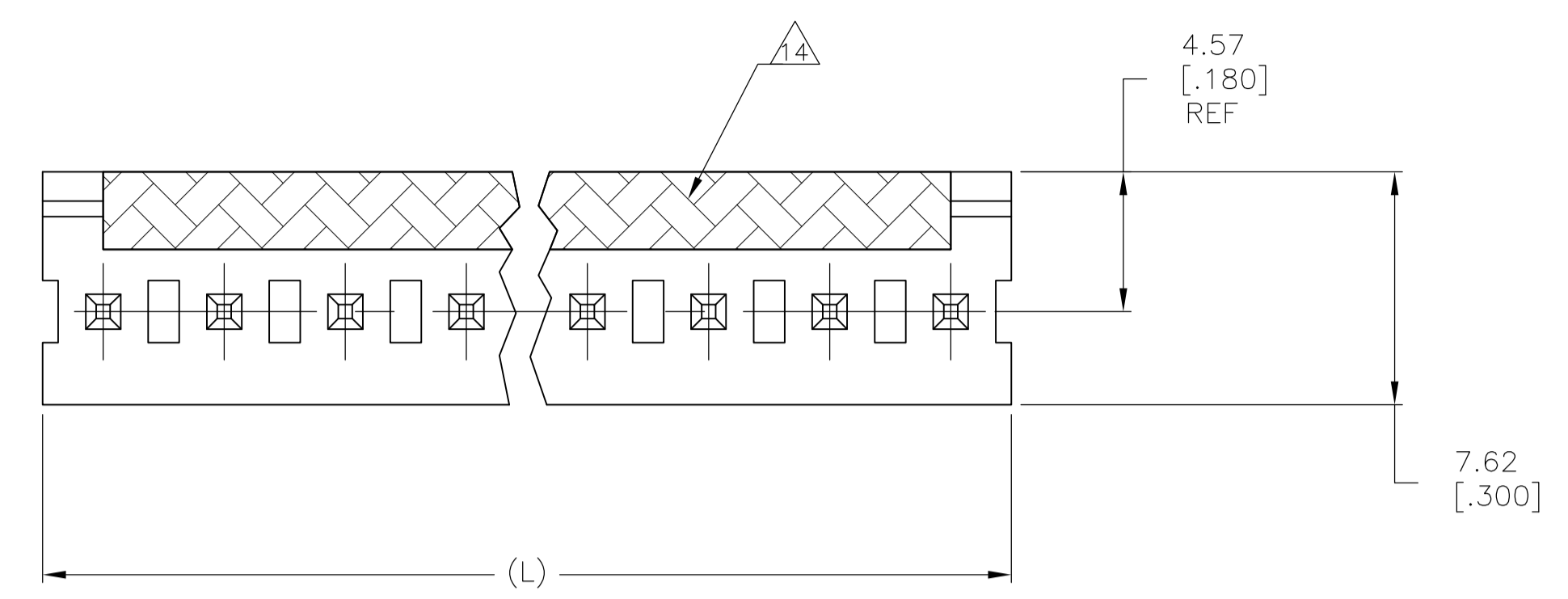

RECOMMENDED MOUNTING HOLE PATTERN FOR 1.60 [.063] THICK P.C. BOARD 2

- 1 POST TO WITHSTAND 13 NEWTONS (3LBS.) MIN. AXIAL FORCE IN BOTH DIRECTIONS SHOWN WITHOUT DISLODGING.
- 2 TOLERANCES APPLY TO SOLDER SIDE OF BOARD.
- 4 PLASTIC FLASH PERMITTED IN THIS AREA.
- 5 PARTS COMPLY WITH AMP SOLDERABILITY SPEC. NO. 109-11-2.
- 6 ONE HOLE MAY BE UNDERSIZED (.065/.060 DIA.) FOR ASSEMBLY RETENTION DURING WAVE SOLDERING.
- 7 MATERIAL: HEADER-THERMOPLASTIC POLYESTER GLASS-FILLED 94V-0 (NATURAL) POST-COPPER ALLOY (TIN PLATED)
- 8 COORDINATE DIMENSION APPLIES FROM CENTER OF ACTUAL FEATURE.
- 9 PLASTIC BURRS CAUSED BY CUT-OFF TOOLING ARE PERMITTED WITHIN THE MAXIMUM TOLERANCE ENVELOPE.
- 11 POST MUST WITHSTAND TWO 90° BENDS AGAINST EXTRUSION WITHOUT BREAKING.
- 12 DIMENSION SHOULD BE 4.45 [.175] MIN WHEN MATING WITH A MTA-156 CONNECTOR ASSEMBLY OR A SL-156 CONNECTOR ASSEMBLY.
- 13 PIN BURR OF 0.127 [.005] MAX. VERTICAL AND 0.076 [.003] MAX. HORIZONTAL PERMITTED AT POST TIPS ON BOTH ENDS.
- 14 COLOR STRIPE BLACK IN APPROXIMATE LOCATION SHOWN

7.92	.312	2	1744000-2
MM	[IN]	NUMBER OF POSITIONS	PART NUMBER
L			

THIS DRAWING IS A CONTROLLED DOCUMENT.

DIMENSIONS: mm [INCHES]	TOLERANCES UNLESS OTHERWISE SPECIFIED:	DIN S. HOOVER 07OCT03	REV. 07OCT03
0 PLC ± -	1 PLC ± -	2 PLC ± 0.38[.015]	3 PLC ± -
4 PLC ± -	ANGLES ± -	APPROD D. ROSSI 07OCT03	NAME
MATERIAL 7	FINISH 7	APPLICATION SPEC	MTA-.156 HEADER ASSEMBLY, FRICTION LOCK, STRAIGHT .045 SQUARE POST, TIN PLATED, SPECIAL
WEIGHT	SIZE	CAGE CODE	DRAWING NO
CUSTOMER DRAWING	A1	00779	1744000
SCALE	SHEET	OF	REV
5:1	1	1	

STE TE Connectivity

单击下面可查看定价，库存，交付和生命周期等信息

[>>TE Connectivity\(泰科\)](#)