

LOC		DIST		REVISIONS			
P	LTR	DESCRIPTION	DATE	DN	APVD		
L		REV PER ECO 13-013418	9-19-13	CT	CD		

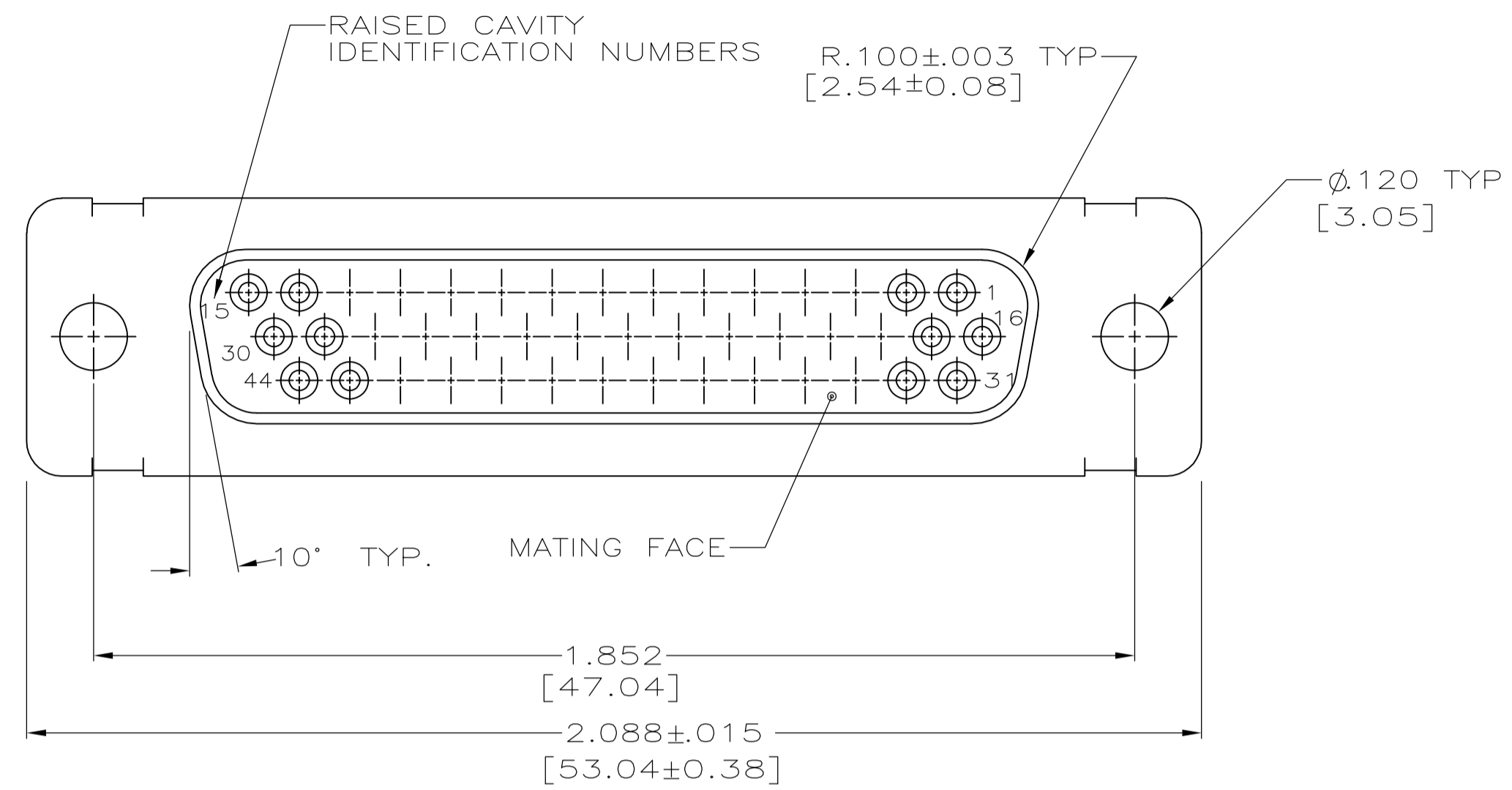

- THIS RECEPTACLE WILL MATE WITH ANY 44 POSN, SIZE 3 PLUG IN AMPLIMITE SERIES.
- BE-CU RETENTION CLIPS (44) ARE INCLUDED IN INSERT AND INSTALLED WITH TINES.
- POINTING TOWARDS MATING FACE
- CONNECTOR SUPPLIED WITHOUT CONTACTS, SHOWN FOR ILLUSTRATION ONLY
- OVERALL DIMENSIONS DO NOT INCLUDE RAISED CAVITY ID
- MARKING: FAR SIDE REFERS TO WIDE SIDE OF KEYSTONE. NEAR SIDE REFERS TO NARROW SIDE OF KEYSTONE
- 100% INSPECTION REQUIRED PER BOEING 1B01:
 - VISUAL
 - DWV
 - IR
- CUSTOMER REQUIRES SINGLE LOT DATE CODE.
- SPECIAL REQUIREMENTS:
 - TEST TWO CONNECTORS PER LOT FOR COMPLIANCE TO GROMMET PEEL STRENGTH REQUIREMENTS.
 - TEST ALL CIRCUIT CAVITIES FOR MISALIGNMENT OR EXCESSIVE ADHESIVE.

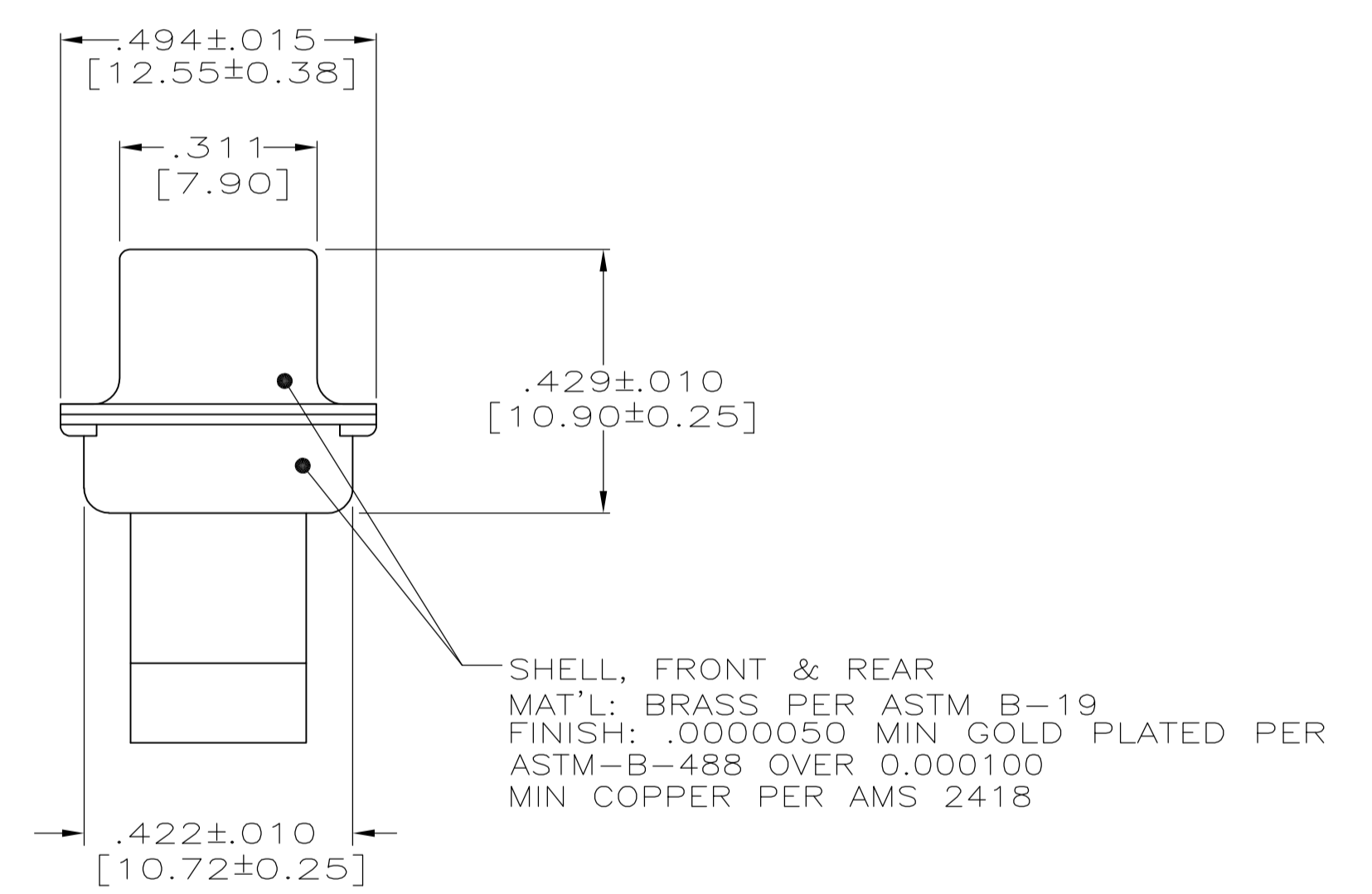
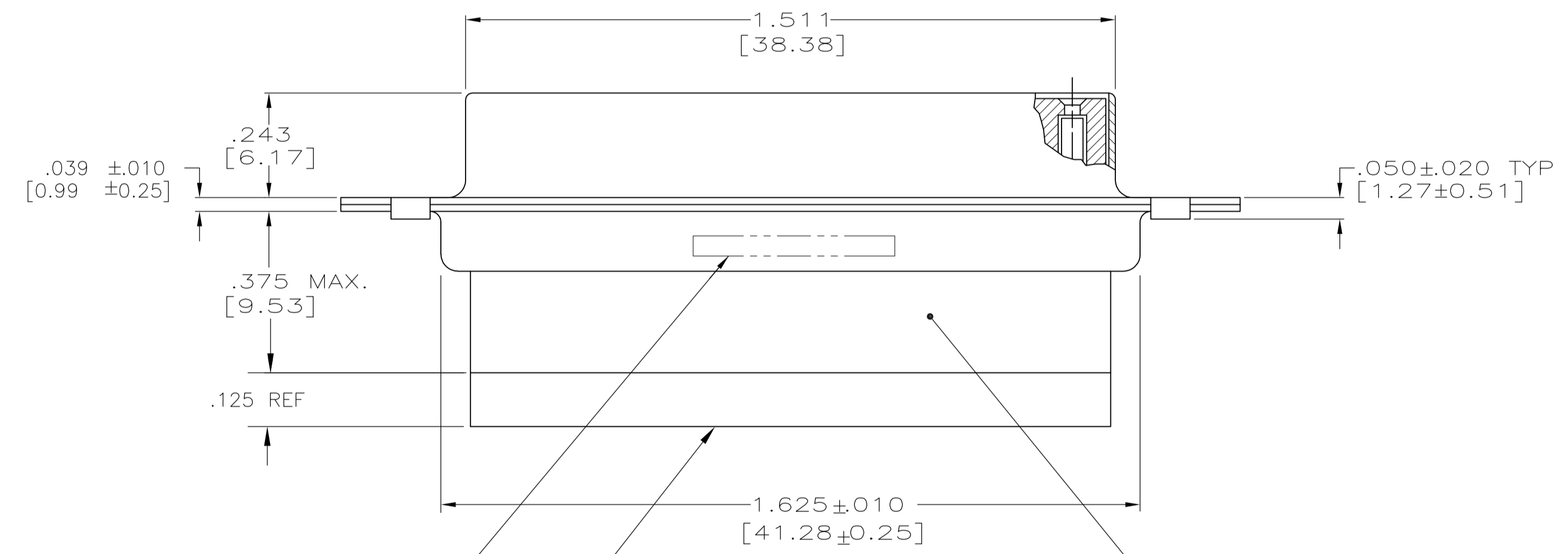

△ CUSTOMER P/N (IF APPLICABLE) MARKED ON FAR SIDE. MANUFACTURER'S NAME, BRAND NAME OR LOGO AND MANUFACTURER'S PART NO AND DATE CODE MARKED ON NEAR SIDE

INSERT ASSEMBLY
POLYPHENYLENE SULFIDE (PPS) GST-40-F PER MIL-M-24519 OR GLASS FILLED POLYESTER TPES013G30 PER ASTM-D-5927

GROMMET MATERIAL: SILICONE RUBBER

1B01-027RHW	1-211669-1
--	211669-4
2A065-021V-001	211669-2
1B01-027	211669-1
CUSTOMER MARKING	PART NO

THIS DRAWING IS A CONTROLLED DOCUMENT.

DIMENSIONS: INCHES	TOLERANCES UNLESS OTHERWISE SPECIFIED:	0 PLC ± -	1 PLC ± -	2 PLC ± -	3 PLC ± .005 [0.13]	4 PLC ± -	ANGLES ± -
--------------------	--	-----------	-----------	-----------	---------------------	-----------	------------

MATERIAL: SEE CALLOUTS FINISH: SEE CALLOUTS WEIGHT: --

APPROVED: P. YEAGER 26JUN06, D. MILLER 30JUN06, D. MILLER 30JUN06

NAME: RECEPTACLE ASSEMBLY, AMPLIMITE 44 POSITION, SIZE 3, SERIES 90, NON-MAGNETIC, SPECIAL WITH GROMMET

SIZE: A1 CAGE CODE: 00779 DRAWING NO: 211669 RESTRICTED TO: --

CUSTOMER DRAWING SCALE: 4:1 SHEET: 1 OF 1 REV: L

单击下面可查看定价，库存，交付和生命周期等信息

[>>TE Connectivity\(泰科\)](#)