

REVISIONS					
P	LTR	DESCRIPTION	DATE	DWN	APVD
	M	REV PER 0G3A-0668-04	24AUG04	JR	TM
	N	REVISED PER ECO-17-014338	09MAY2018	RS	DR

<b>AMP</b> WIRE RANGE	Listed FILE E13288	LR7189 Certified
12-10 AWG SOLID OR STRANDED	12-10 AWG SOLID OR STRANDED	12-10 AWG SOLID OR STRANDED

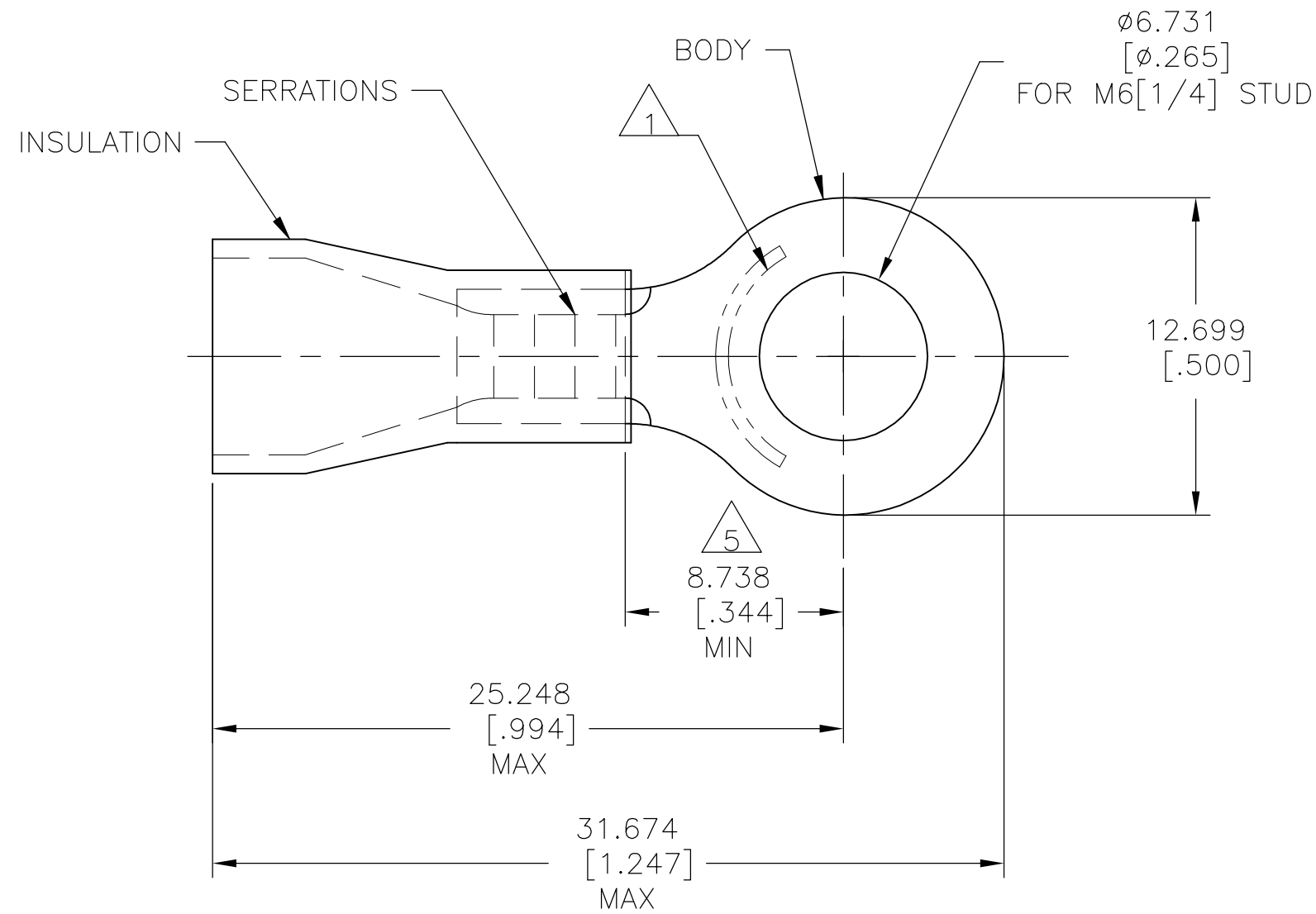

- 1 STAMP AMP 12-10\* APPROX AS SHOWN
- 2 WIRE INSULATION DIA:  $\phi 7.620[\phi.300]$  MAX
- 3 BODY MATERIAL THK:  $0.991 \pm 0.051[.039 \pm .002]$
- 4 MATERIAL: BODY - CU PER ASTM B152  
SLEEVE - PVC
- 5 APPLIES FROM CENTER OF STUD HOLE  
TO EDGE OF METAL WIRE BARREL

500	LOOSE PIECE	35492
QTY	PACKAGE TYPE	PART NO.

<b>AMP INCORPORATED CUSTOMER SERVICE SYSTEMS</b>		MAX RECOMMENDED OPERATING TEMPERATURE: 105°C [221°F]	THIS DRAWING IS A CONTROLLED DOCUMENT.		DWN DK SCHRUM 08/06/92	TE Connectivity Ltd.			
FOR ADDITIONAL PRODUCT INFORMATION OR COPIES OF DRAWINGS AND TECHNICAL DOCUMENTS	PRODUCT INFORMATION CENTER 1-800-522-6752	VOLTAGE RATING: 600V MAX (1000V FIXTURE OR SIGN)	DIMENSIONS: mm [INCHES]	TOLERANCES UNLESS OTHERWISE SPECIFIED:	CHK RE HERSEY 11/10/92				NAME TERMINAL, RING TONGUE, PLASTI-GRIP WIRE SIZE : 12-10 AWG
FOR APPLICATION TOOLING INFORMATION	TOOLING ASSISTANCE CENTER 1-800-722-1111	CIRCULAR MIL AREA: 2.62-6.64mm <sup>2</sup> [5,180-13,100] SOLID OR STRANDED		0 PLC ± - 1 PLC ± - 2 PLC ± - 3 PLC ± 0.127[.005] 4 PLC ± - ANGLES ± -	APVD M BARNABA 11/10/92	PRODUCT SPEC UL486A-B			
FOR ORDER ENTRY	1-800-526-5142	THIS DRAWING IS A CONTROLLED DOCUMENT FOR AMP INCORPORATED. IT IS SUBJECT TO CHANGE AND THE CONTROLLING ENGINEERING ORGANIZATION SHOULD BE CONTACTED FOR THE LATEST REVISION.	MATERIAL 	FINISH BODY: TIN PER ASTM B545 INSULATION: COLOR - BLACK	APPLICATION SPEC 114-2161	SIZE A3	CAGE CODE 00779	DRAWING NO C-35492	RESTRICTED TO -
			CUSTOMER DRAWING	SCALE 4:1	SHEET 1 OF 1	REV N			

单击下面可查看定价，库存，交付和生命周期等信息

[>>TE Connectivity\(泰科\)](#)