

LOC	DIST	REVISIONS					
		P	LTN	DESCRIPTION	DATE	DMN	APVD
GP	00	I		PRELIMINARY	23FEB2012	KS	AC
		A		REVISED PER ECR-12-006970	17APR2012	KS	AC
		B		REVISED PER ECO-15-005721	4AUG2015	RG	SH

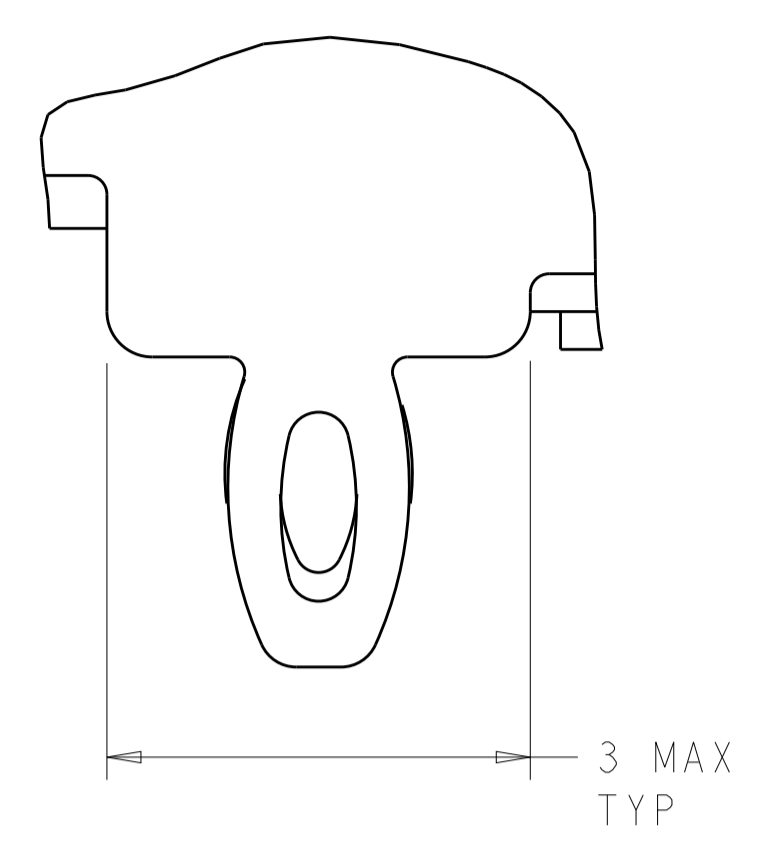

DETAIL S $\Delta 12$
 SCALE 20:1

- $\Delta 1$ MATERIALS:
 CAGE ASSEMBLY: NICKEL SILVER, 0.25 THICK
 EMI SPRINGS: COPPER ALLOY
 EMI GASKET: BURRER FOAM
 FRONT FLANGE: ZINC ALLOY
 HEAT SINK: ALUMINUM
 HEAT SINK CLIP: STAINLESS STEEL
- $\Delta 2$ PITCH BETWEEN PORTS OF ONE 1X3 CAGE ASSEMBLY.
- $\Delta 3$ SPACING BETWEEN CAGES ON THE SAME PC BOARD, TO BE SPECIFIED BY CUSTOMER, MUST COMPLY WITH MINIMUM DIMENSIONS SHOWN.
- $\Delta 4$ REFERENCE APPLICATION SPEC 114-13218 FOR RECOMMENDED DRILL HOLE DIAMETER AND PLATING THICKNESS.
- $\Delta 5$ DATUMS AND BASIC DIMENSIONS ESTABLISHED BY CUSTOMER.
- $\Delta 6$ DIMENSION C IS THE NOMINAL THICKNESS OF CUSTOMER SUPPLIED PC BOARD.
 MINIMUM SINGLE SIDED PC BOARD THICKNESS: 1.45mm
 MINIMUM DOUBLE SIDED PC BOARD THICKNESS: 2.2mm PER QSFP
- $\Delta 7$ HEAT SINKS AND CLIPS SHIPPED ASSEMBLED TO CAGE ASSEMBLY. CAGE ASSEMBLY MAY BE PRESSED INTO THE PCB AS SHIPPED.
- $\Delta 8$ DATUM -A- IS TOP SURFACE OF PC BOARD.
- $\Delta 9$ DIMENSION APPLIES WITH MODULE INSERTED IN CAGE.
- $\Delta 10$ UNPLATED THRU HOLE.
- 11. MATES WITH QSFP MSA COMPATIBLE TRANSCEIVER.
- $\Delta 12$ SURFACE TRACES PERMITTED WITHIN THIS AREA EXCEPT WHERE CAGE STANDOFFS, SHOWN IN DETAIL S, CONTACT PC BOARD.

- $\Delta 3$ BASELINE FOR THESE DIMENSIONS IS THE CENTER OF COMPLIANT PIN HOLE.
- $\Delta 4$ 2D BARCODE AND DATE CODE (YYWW) MARKED ON SIDE OF CAGE.
- $\Delta 5$ REFERENCE APP SPEC 114-13218 FOR GASKET THICKNESS CALCULATION.
- $\Delta 6$ FINISH:
 EMI SPRINGS: 2 μ m MINIMUM TIN
 FRONT FLANGE: 3 μ m MINIMUM TIN OVER 1.27 μ m MINIMUM NICKEL OVER 5.08 μ m MINIMUM COPPER
 HEAT SINK: NICKEL.

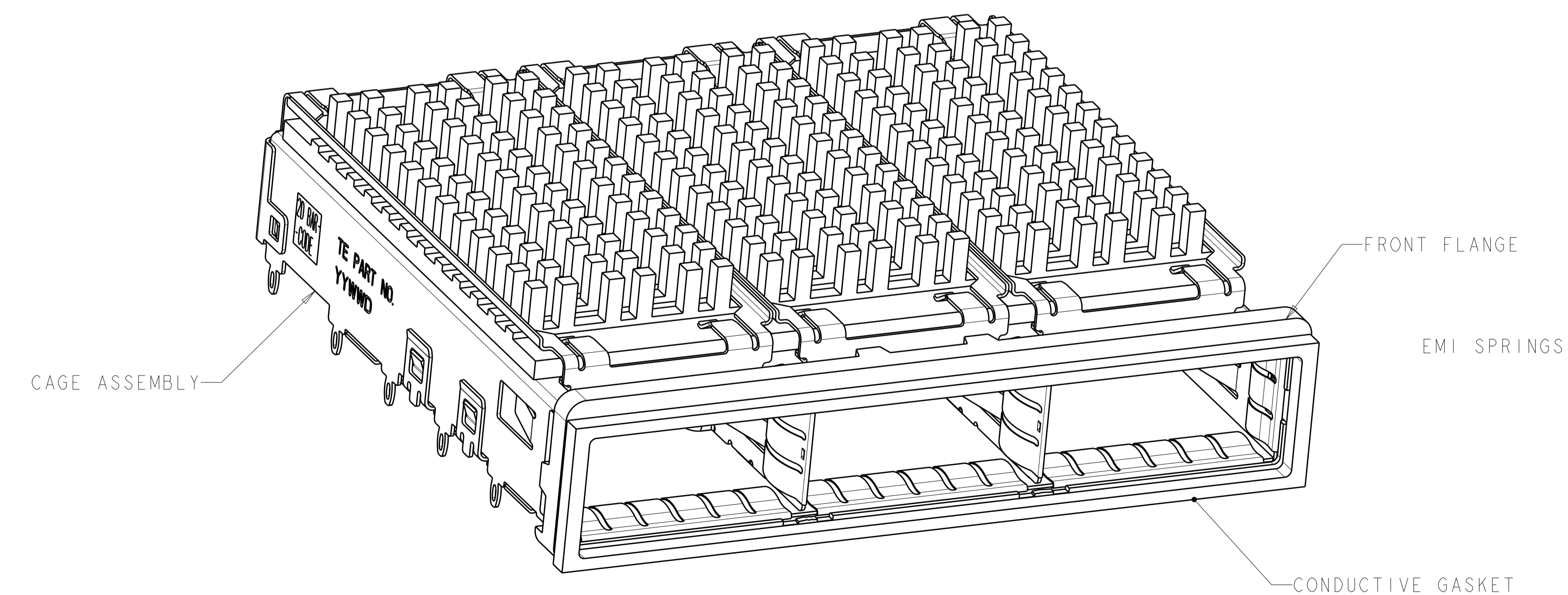
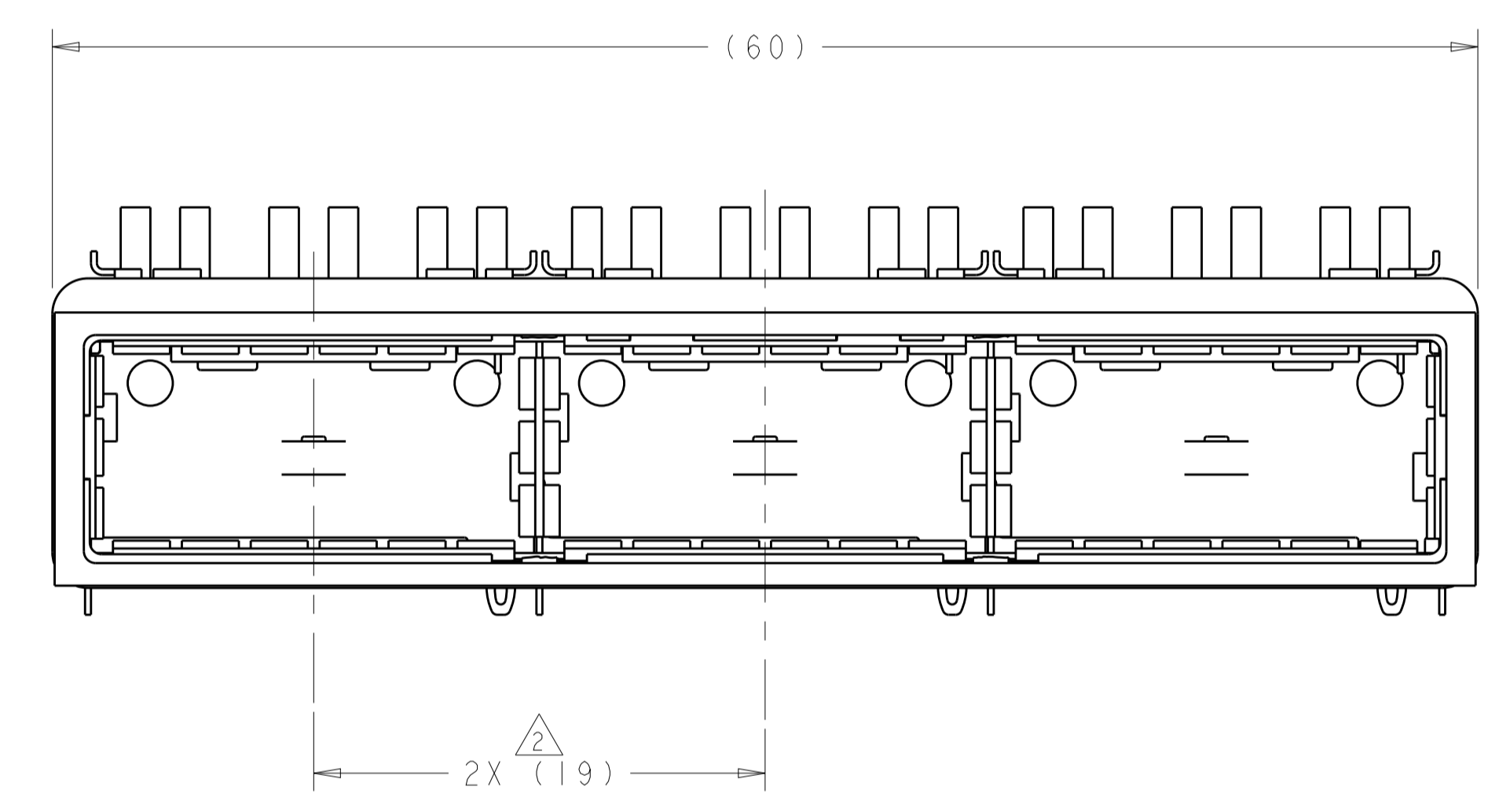
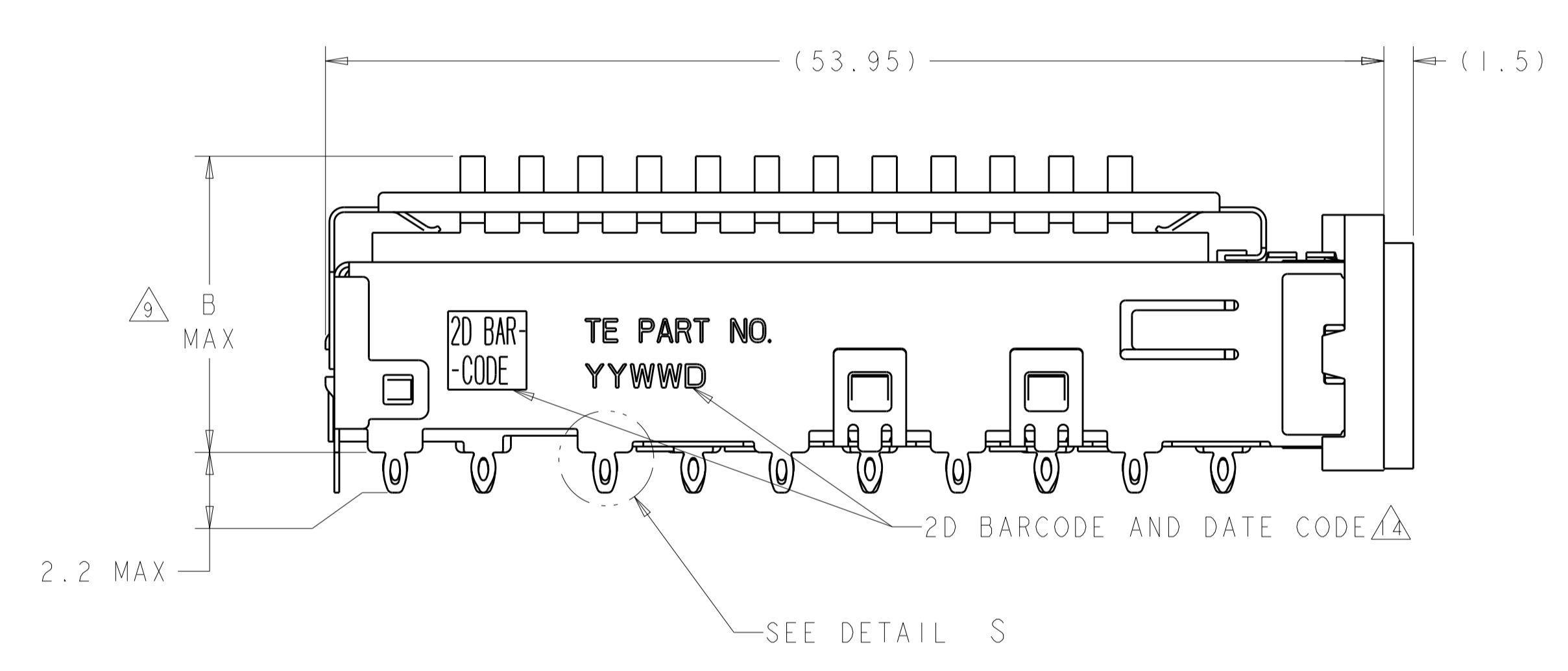

23.0	NETWORKING	2174769-3
16.0	SAN	2174769-2
13.7	PCI	2174769-1
B	HEAT SINK PROFILE	PART NUMBER

THIS DRAWING IS A CONTROLLED DOCUMENT.		DMN: KINSEN SUN 23FEB2012	
DIMENSIONS: mm		CHK: DENNY ZHU 23FEB2012	
TOLERANCES UNLESS OTHERWISE SPECIFIED:		APVD: ALEY CAI 23FEB2012	NAME: 1X3 CAGE ASSEMBLY, BEHIND BEZEL, W/ HEAT SINKS, CONDUCTIVE GASKET, QSFP PRODUCT SPEC: 108-2286 APPLICATION SPEC: 114-13218
0 PLC \pm 1 PLC ± 0.1 2 PLC ± 0.1 3 PLC ± 0.013 4 PLC ± 0.0001 ANGLES \pm		WEIGHT: - CUSTOMER DRAWING	
MATERIAL: $\Delta 1$		FINISH: $\Delta 6$	SIZE: A1 CAGE CODE: 00779 DRAWING NO: C=2174769 RESTRICTED TO: - SCALE: 4:1 SHEET 1 OF 5 REV B

LOC	DIST	REVISIONS			
P	LTN	DESCRIPTION	DATE	OWN	APVD
GP	00	SEE SHEET 1	-	-	-

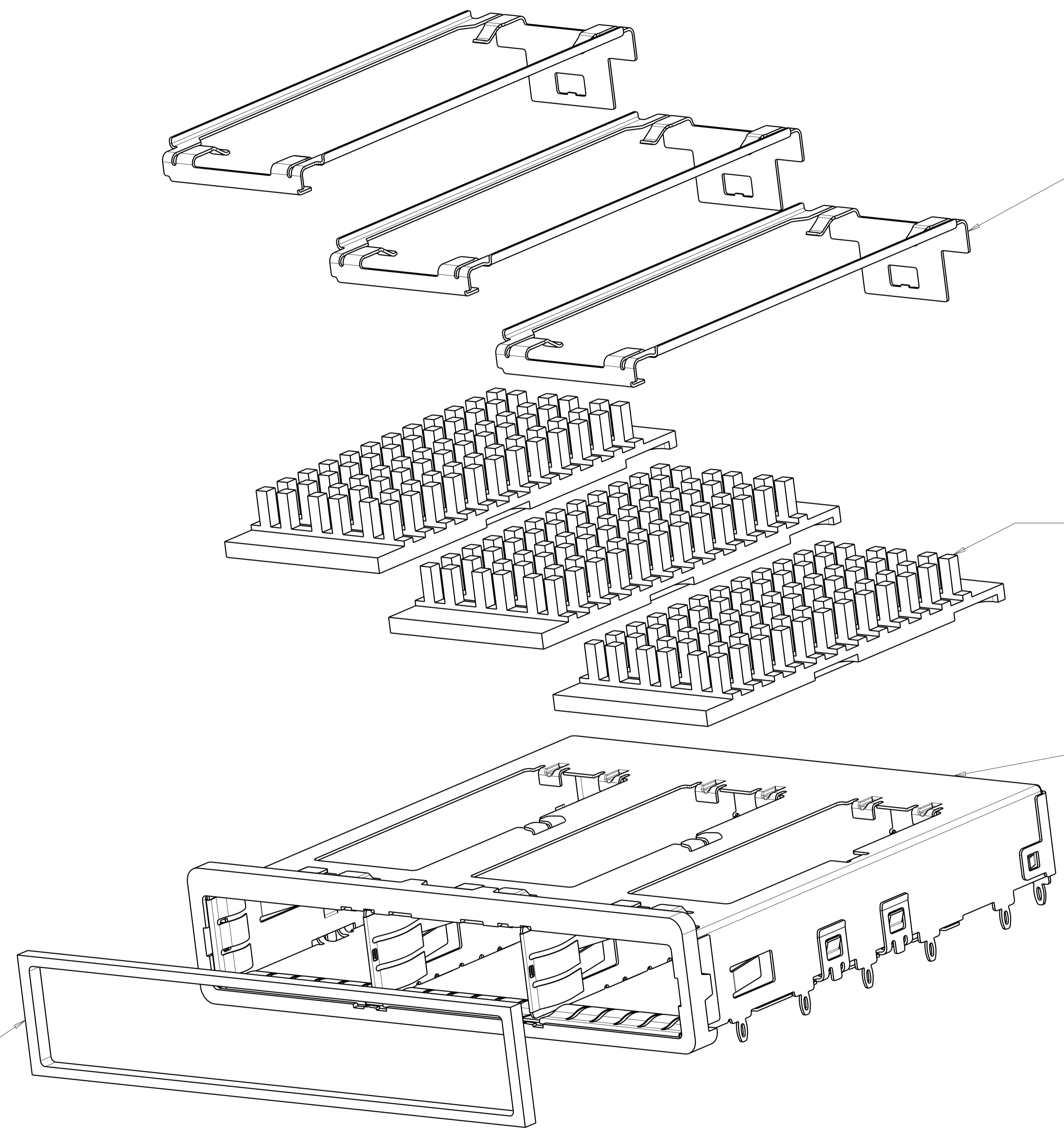

HEAT SINK CLIP
 QUANTITY: 3

72 PIN HEAT SINK
 QUANTITY: 3

IX3 BEHIND BEZEL QSFP
 CAGE ASSEMBLY
 QUANTITY: 1

IX3 CONDUCTIVE GASKET
 QUANTITY: 1

THIS DRAWING IS A CONTROLLED DOCUMENT.		OWN: KINSEN SUN 23FEB2012	
DIMENSIONS: mm		CHK: DENNY ZHU 23FEB2012	
TOLERANCES UNLESS OTHERWISE SPECIFIED:		APVD: AILEY CAI 23FEB2012	NAME: IX3 CAGE ASSEMBLY, BEHIND BEZEL, W/ HEAT SINKS, CONDUCTIVE GASKET, QSFP
0 PLC ±	1 PLC ±0.1	PRODUCT SPEC: 108-2286	SIZE: A1
2 PLC ±0.1	3 PLC ±0.013	APPLICATION SPEC: 114-13218	CAGE CODE: 00779
4 PLC ±0.0001	ANGLES ±	WEIGHT: -	DRAWING NO: C=2174769
MATERIAL: -	FINISH: -	CUSTOMER DRAWING	RESTRICTED TO: -
SCALE: 4:1			SHEET: 2 OF 5
REV: B			

LOC	DIST	REV	DATE	BY	APPV
GP	00				

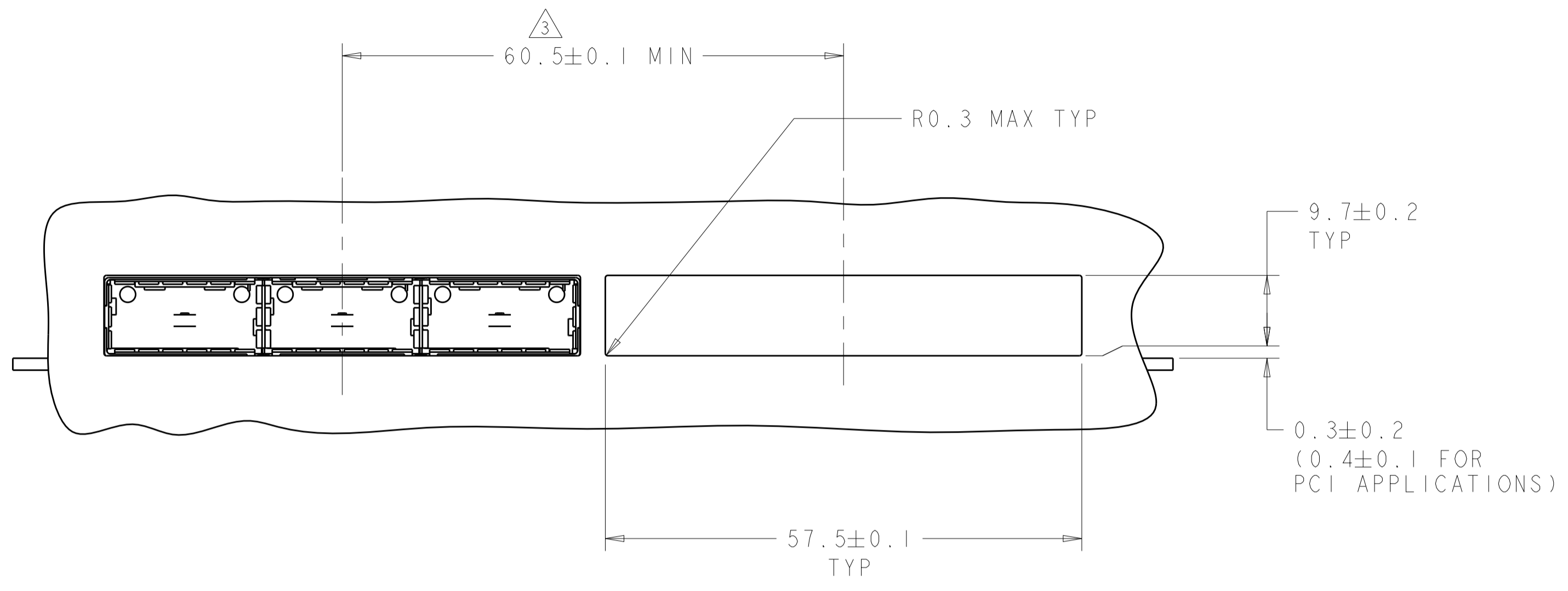

ONE SIDED CONFIGURATION
 SCALE 2:1

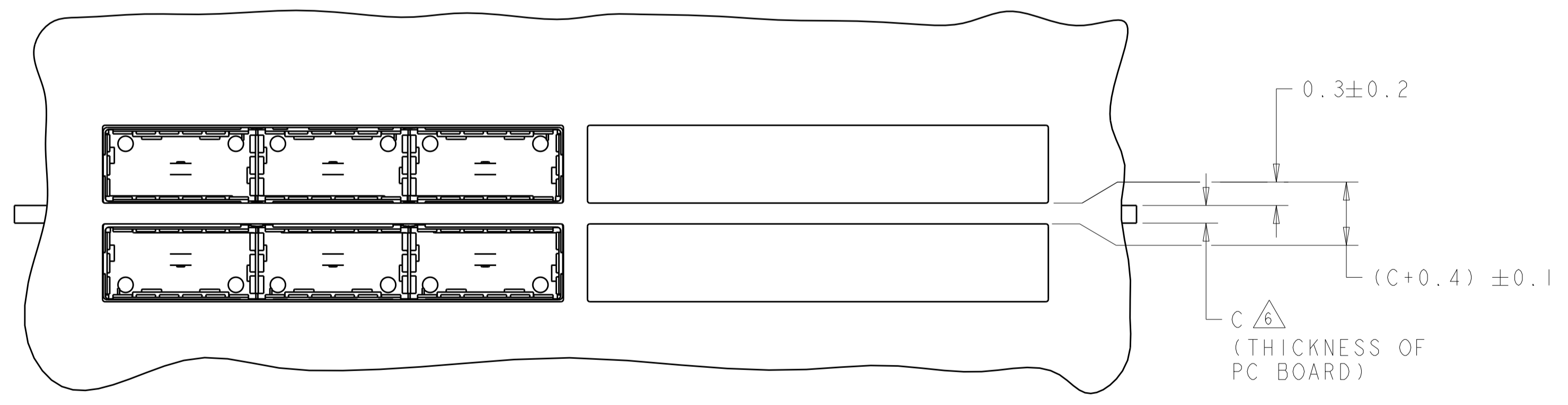
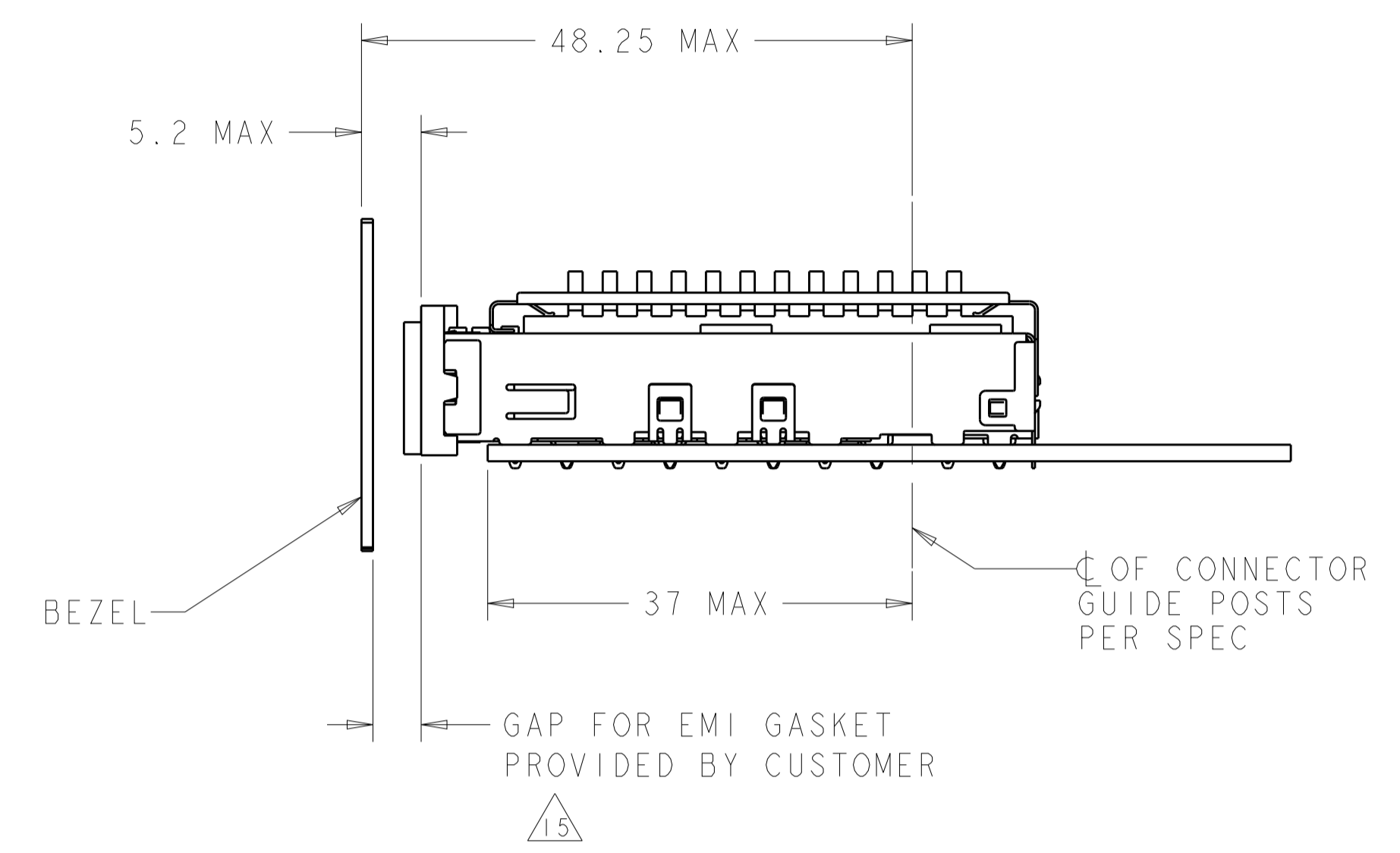

BELLY TO BELLY CONFIGURATION SIMILAR
 TO ONE SIDED EXCEPT WHERE NOTED
 SCALE 2:1

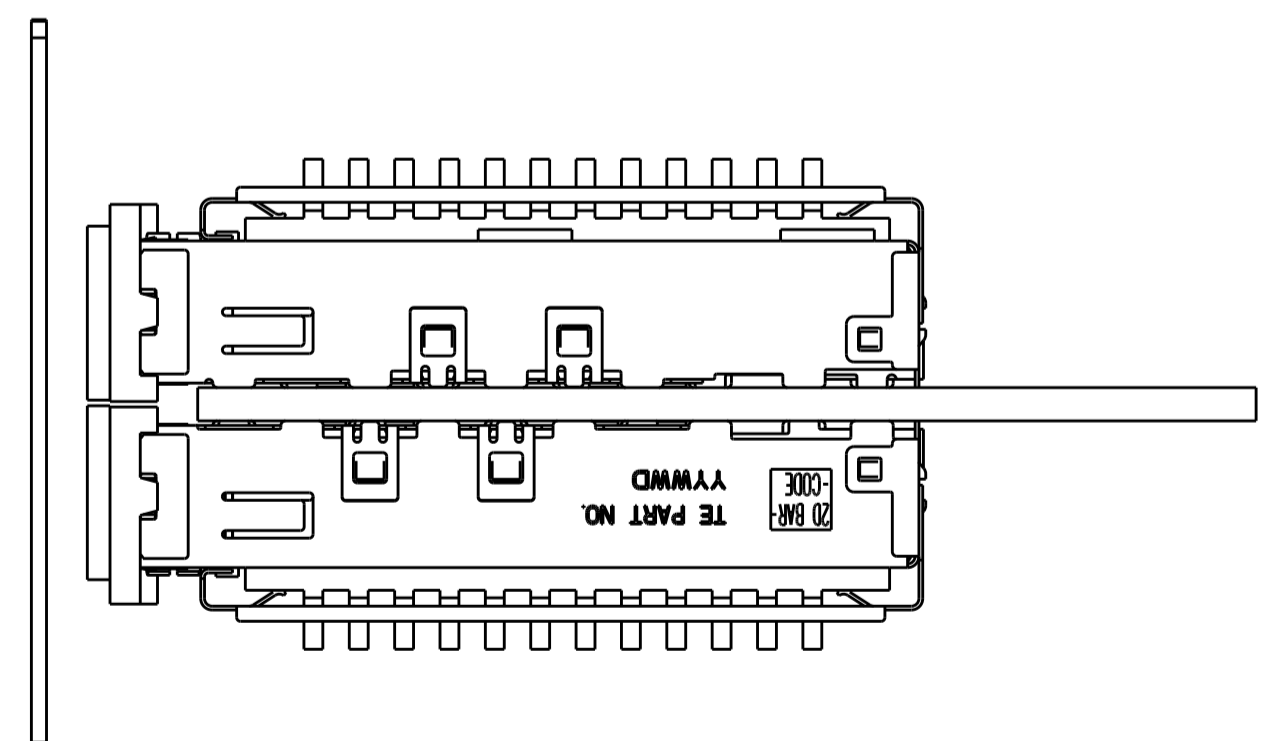

THIS DRAWING IS A CONTROLLED DOCUMENT.		OWN: RINSEN SUN 23FEB2012	
DIMENSIONS: mm		CHK: DENNY ZHU 23FEB2012	
TOLERANCES UNLESS OTHERWISE SPECIFIED:		APVD: AILEY CAI 23FEB2012	NAME: 1X3 CAGE ASSEMBLY, BEHIND BEZEL, W/ HEAT SINKS, CONDUCTIVE GASKET, QSFP
0 PLC ±	1 PLC ±0.1	PRODUCT SPEC	SIZE: CAGE CODE DRAWING NO
2 PLC ±0.1	3 PLC ±0.013	108-2286	RESTRICTED TO
4 PLC ±0.0001	ANGLES ±	APPLICATION SPEC	A100779C=2174769
MATERIAL: -	FINISH: -	114-13218	SCALE: 4:1 SHEET 3 OF 5 REV B
CUSTOMER DRAWING		WEIGHT: -	

LOC	DIST	REV	DATE	BY	APPD
GP	00				

REVISIONS					
REV	DATE	BY	APPD	DESCRIPTION	DATE
-	-	-	-	SEE SHEET 1	-

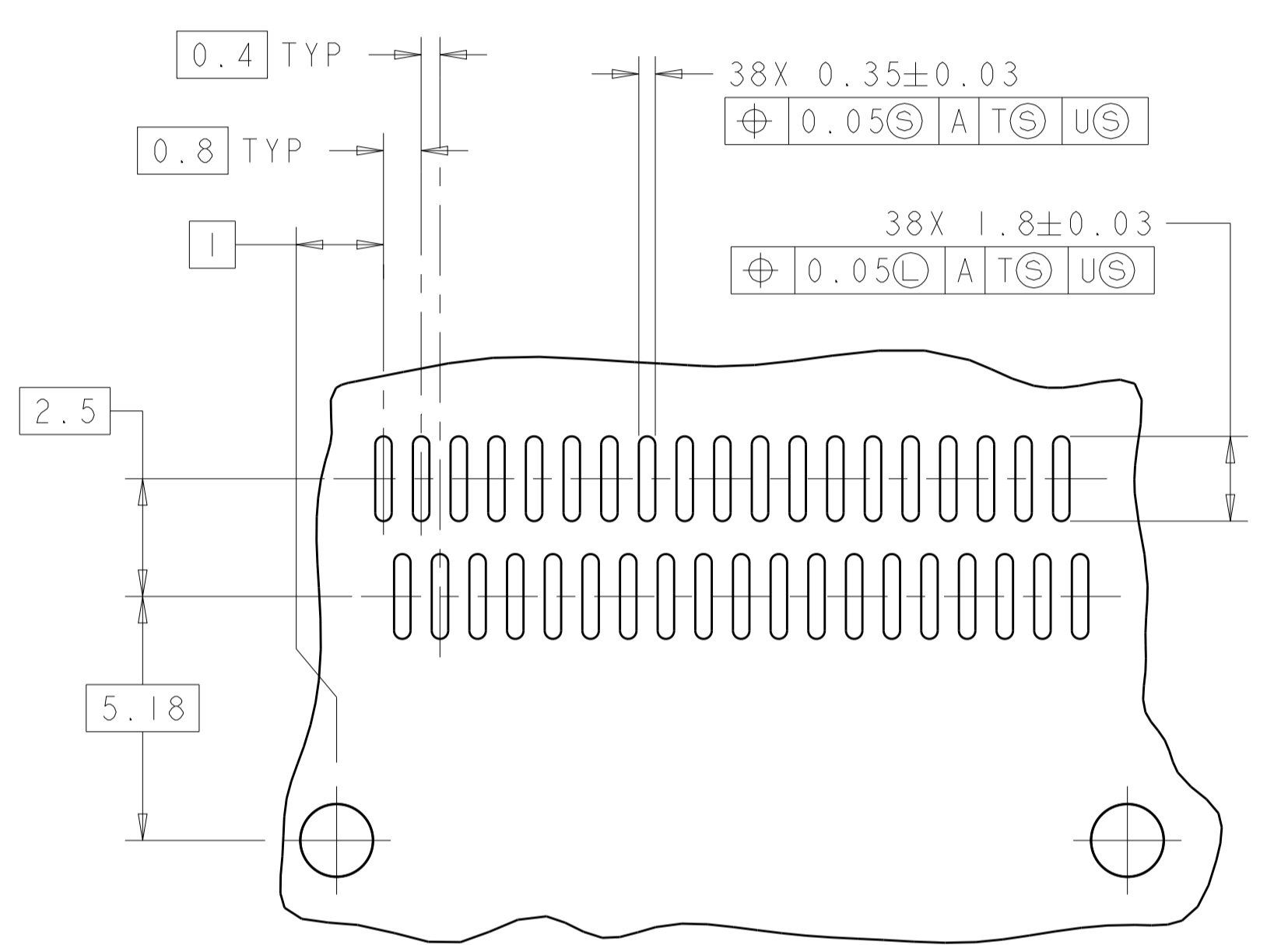
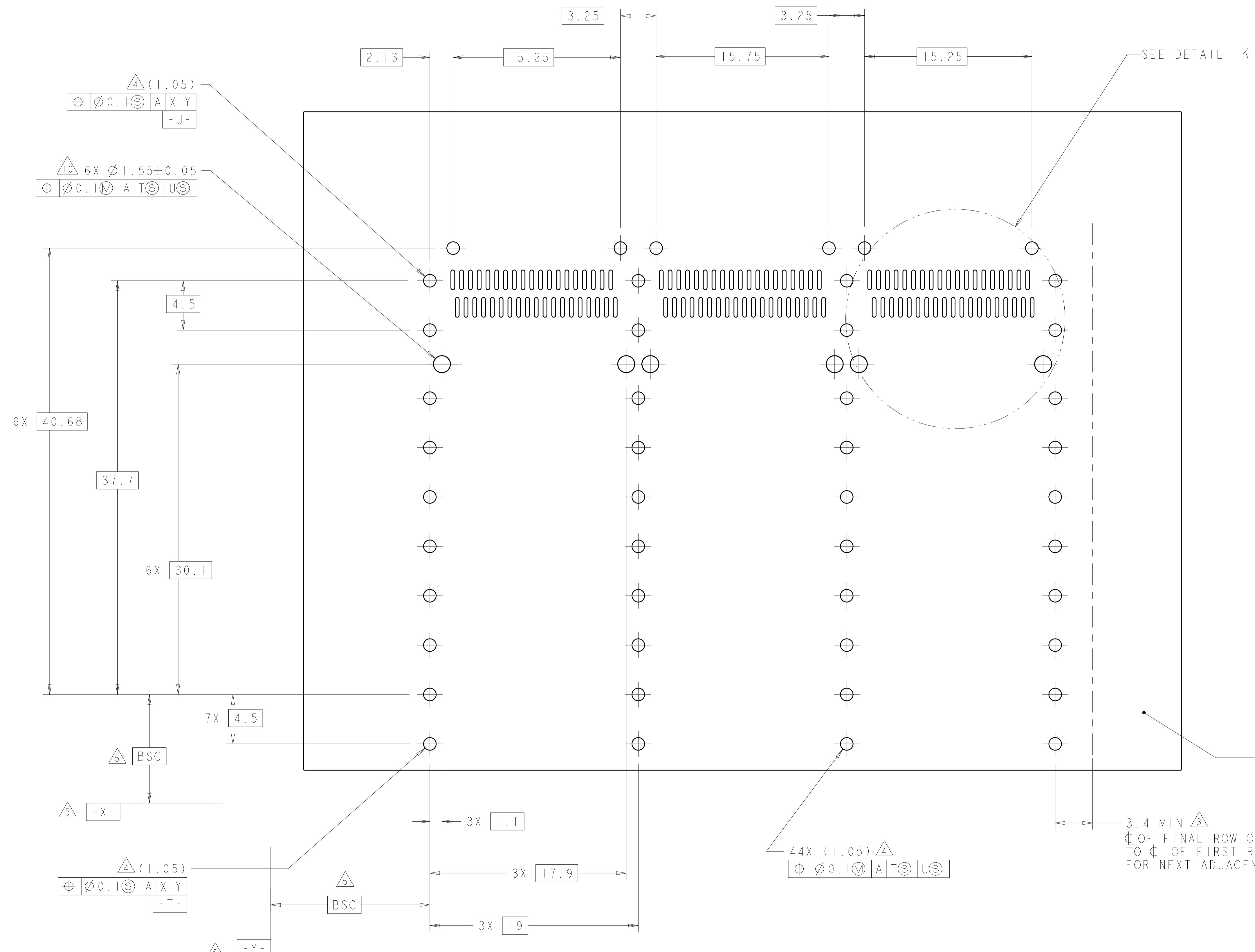

DETAIL K
 3 PLACES
 SCALE 8:1

RECOMMENDED PC BOARD LAYOUT
 BELLY TO BELLY CONFIGURATION
 SEE SHEET 4 FOR COMPONENT
 AND TRACE KEEP-OUTS
 SCALE 5:1

THIS DRAWING IS A CONTROLLED DOCUMENT.		DWN: KINSEN SUN 23FEB2012	TE Connectivity
DIMENSIONS: mm		CHK: DENNY ZHU 23FEB2012	
TOLERANCES UNLESS OTHERWISE SPECIFIED:		APVD: AILEY CAI 23FEB2012	NAME: 1X3 CAGE ASSEMBLY, BEHIND BEZEL, W/ HEAT SINKS, CONDUCTIVE GASKET, QSFP
0 PLC ±0.1	1 PLC ±0.1	PRODUCT SPEC: 108-2286	SIZE: CAGE CODE DRAWING NO: A100779C=2174769
2 PLC ±0.1	3 PLC ±0.013	APPLICATION SPEC: 114-13218	RESTRICTED TO: -
4 PLC ±0.0001	ANGLES ±0.0001	WEIGHT: -	SCALE: 4:1 SHEET 5 OF 5 REV B
MATERIAL: -	FINISH: -	CUSTOMER DRAWING	

单击下面可查看定价，库存，交付和生命周期等信息

[>>TE Connectivity\(泰科\)](#)