

THIS DRAWING IS UNPUBLISHED. RELEASED FOR PUBLICATION
 © COPYRIGHT - By - ALL RIGHTS RESERVED.

LOC	DIST	REVISIONS					
		P	LTR	DESCRIPTION	DATE	DWN	APVD
G	14		E3	REVISED PER ECO-12-007718	04MAY12	KH	DR

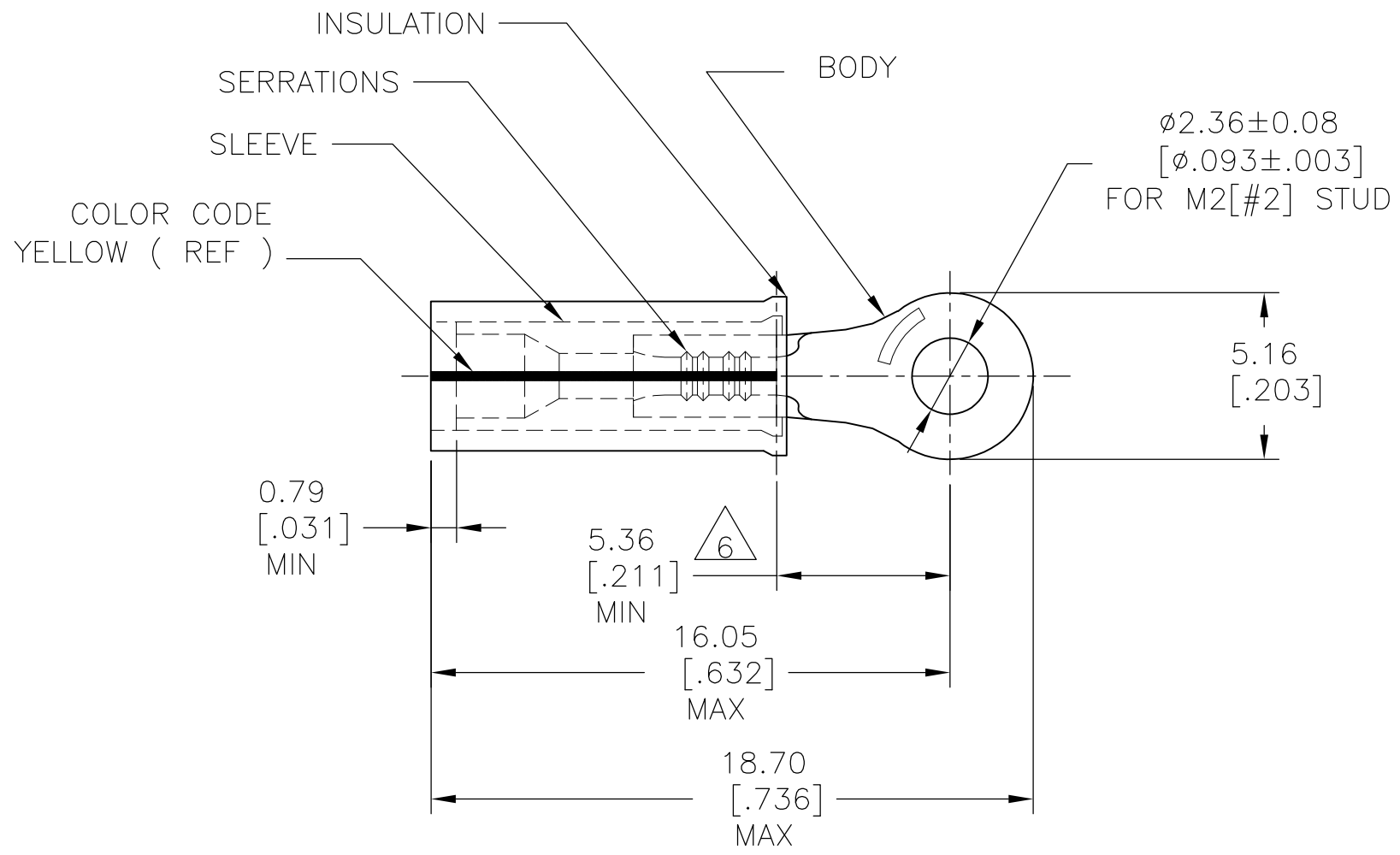

- 1 MUST BE CRIMPED WITH A 22-18 OR 22-16 P.I.D.G. (RED) TOOL.
- 2 WIRE INSULATION DIA: 0.81-2.08 [.032-.082].
- 3 TONGUE MATERIAL THK: 0.69±0.05 [.027±.002].
- △4 BODY & SLEEVE: TIN/LEAD (93-7) PLATE PER ASTM B545. (3% MIN LEAD CONTENT).
- △5 MATERIAL: BODY & SLEEVE- CU PER ASTM B152 INSULATION - PVF2, COLOR - NATURAL.
- △6 DIMENSION APPLIES FROM EDGE OF METAL WIRE BARREL TO CENTER OF STUD HOLE.

M7928/4-143, CLASS 1 & 2 M7928/13-143, CLASS 1 & 2	1000	LOOSE PIECE	53400-1
MILITARY	QTY	PACKAGE TYPE	PART NO.

AMP INCORPORATED CUSTOMER SERVICE SYSTEMS		MAX RECOMMENDED OPERATING TEMPERATURE: 150°C [302°F] MAX
FOR ADDITIONAL PRODUCT INFORMATION OR COPIES OF DRAWINGS AND TECHNICAL DOCUMENTS	PRODUCT INFORMATION CENTER 1-800-522-6752	VOLTAGE RATING: N/A
FOR APPLICATION TOOLING INFORMATION	TOOLING ASSISTANCE CENTER 1-800-722-1111	CIRCULAR MIL AREA: 0.10-0.26mm² [202-509] STRANDED
FOR ORDER ENTRY	1-800-526-5142	THIS DRAWING IS A CONTROLLED DOCUMENT FOR AMP INCORPORATED. IT IS SUBJECT TO CHANGE AND THE CONTROLLING ENGINEERING ORGANIZATION SHOULD BE CONTACTED FOR THE LATEST REVISION.

THIS DRAWING IS A CONTROLLED DOCUMENT.	
DIMENSIONS: mm [INCHES]	TOLERANCES UNLESS OTHERWISE SPECIFIED:
	0 PLC ± -
	1 PLC ± -
	2 PLC ± 0.20[.008]
	3 PLC ± -
	4 PLC ± -
	ANGLES ± -
MATERIAL	FINISH
- △4	- △5

DWN JR RUTH 23MAY05	STE TE Connectivity		
CHK T MICHIELUTTI 23MAY05			
APVD T MICHIELUTTI 23MAY05	NAME TERMINAL, RING TONGUE, PVF2, PIDG WIRE SIZE: 26-24 AWG		
PRODUCT SPEC -	SIZE	CAGE CODE	DRAWING NO
APPLICATION SPEC NOT AVAILABLE	A3	00779	G-53400
WEIGHT -	CUSTOMER DRAWING		RESTRICTED TO -
SCALE 5:1	SHEET 1 OF 1	REV E3	

单击下面可查看定价，库存，交付和生命周期等信息

[>>TE Connectivity\(泰科\)](#)