

REVISIONS					
P.	LTN	DESCRIPTION	DATE	DMN	APVD
A		RELEASED	21MAY2014	CJV	EDB

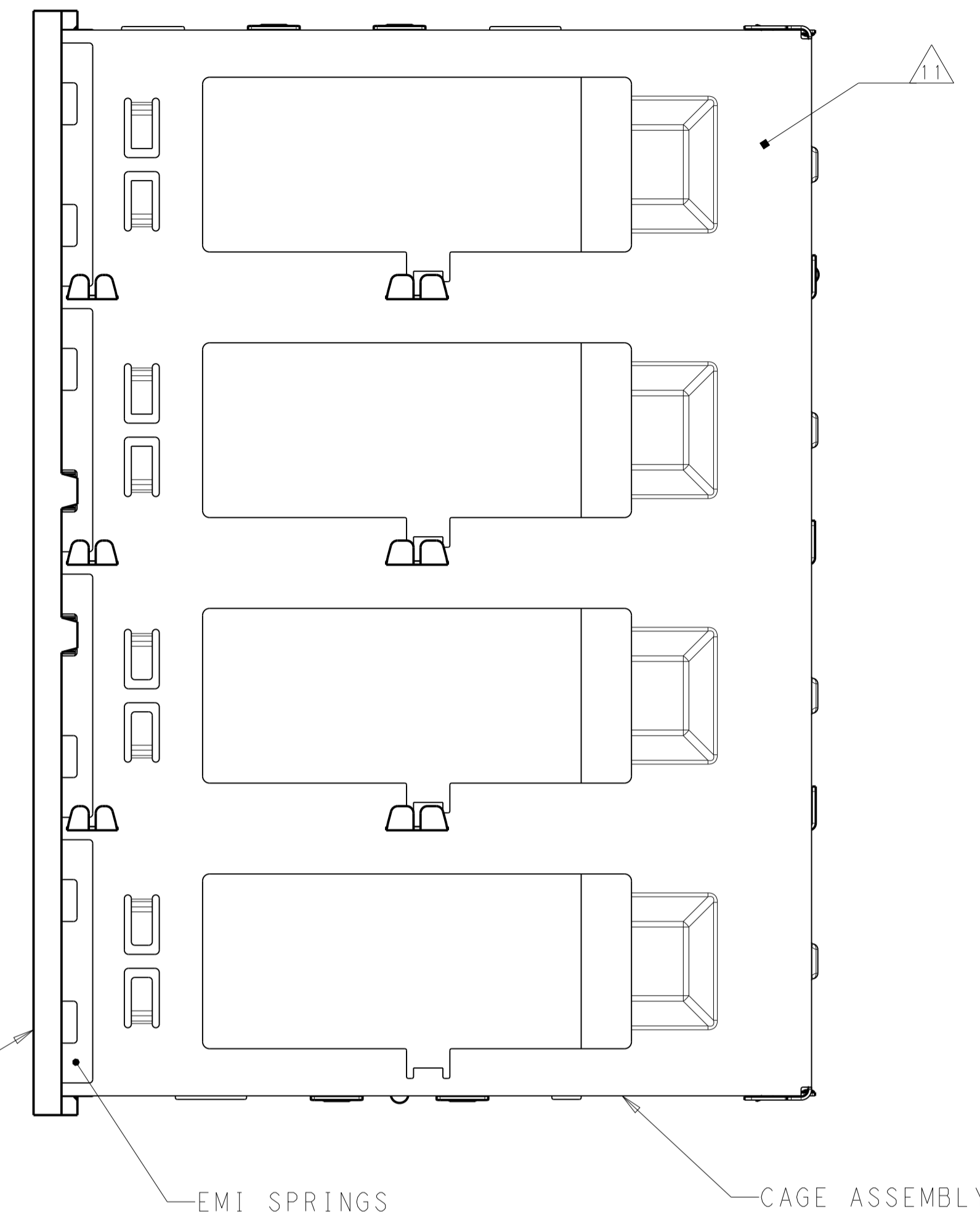

- 1 SURFACE TRACES PERMITTED WITHIN THIS AREA EXCEPT WHERE CAGE STANDOFFS, SHOWN IN DETAIL S, CONTACT PC BOARD.
- 2 PITCH BETWEEN PORTS OF ONE 1X4 CAGE ASSEMBLY.
- 3 SPACING BETWEEN CAGES ON THE SAME PC BOARD, TO BE SPECIFIED BY CUSTOMER, MUST COMPLY WITH MINIMUM DIMENSIONS SHOWN.
- 4 REFERENCE APPLICATION SPEC 114-32023 FOR RECOMMENDED DRILL HOLE DIAMETER AND PLATING THICKNESS.
- 5 UNPLATED THRU HOLE.
- 6 DATUMS AND BASIC DIMENSIONS ESTABLISHED BY CUSTOMER.
- 7 DATUM A IS TOP SURFACE OF PC BOARD.
- 8 DIMENSION C IS THE NOMINAL THICKNESS OF CUSTOMER SUPPLIED PC BOARD.
MINIMUM PC BOARD THICKNESS:
SINGLE SIDED = 1.45mm
DOUBLE SIDED = 2.2mm
- 9 MATES WITH QSFP MSA COMPATIBLE TRANSCEIVER.
- 10 BASELINE FOR THESE DIMENSIONS IS THE CENTER OF COMPLIANT PIN HOLE.
- 11 DATE CODE (YYWWD) MARKED APPROXIMATELY AS SHOWN.
- 12 REFERENCE APP SPEC 114-32023 FOR GASKET THICKNESS CALCULATION.
- 13 MATERIAL:
CAGE ASSEMBLY: NICKEL SILVER, 0.25 THICK
EMI SPRINGS: COPPER ALLOY
FRONT FLANGE: ZINC ALLOY
- 14 FINISH:
EMI SPRINGS: 2µm MINIMUM TIN
FRONT FLANGE: 3µm MINIMUM TIN OVER 1.27µm MINIMUM NICKEL OVER 5.08µm MINIMUM COPPER.

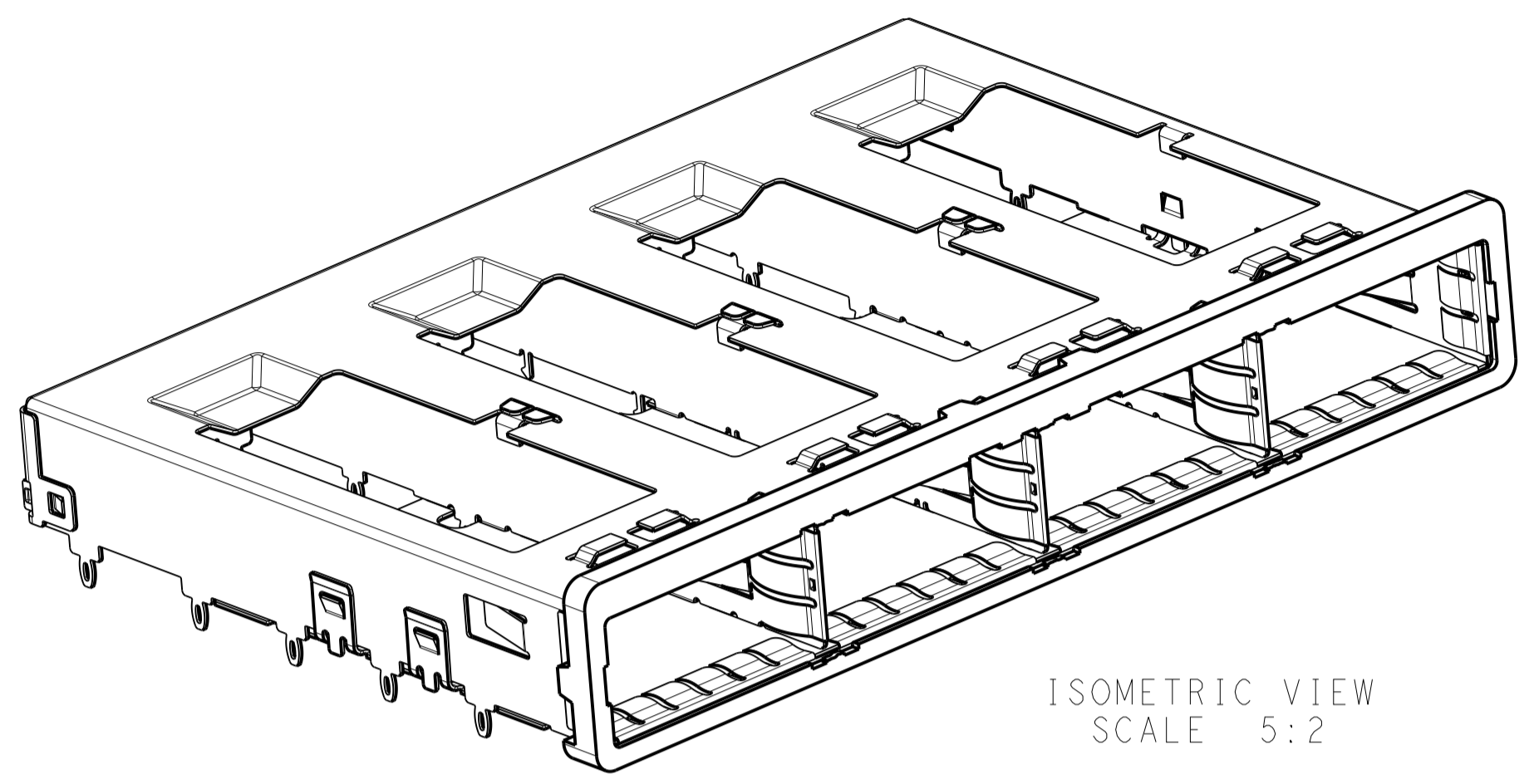
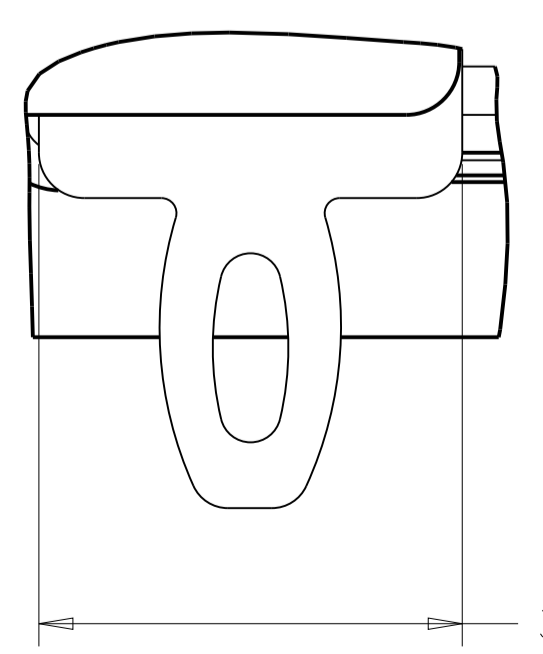
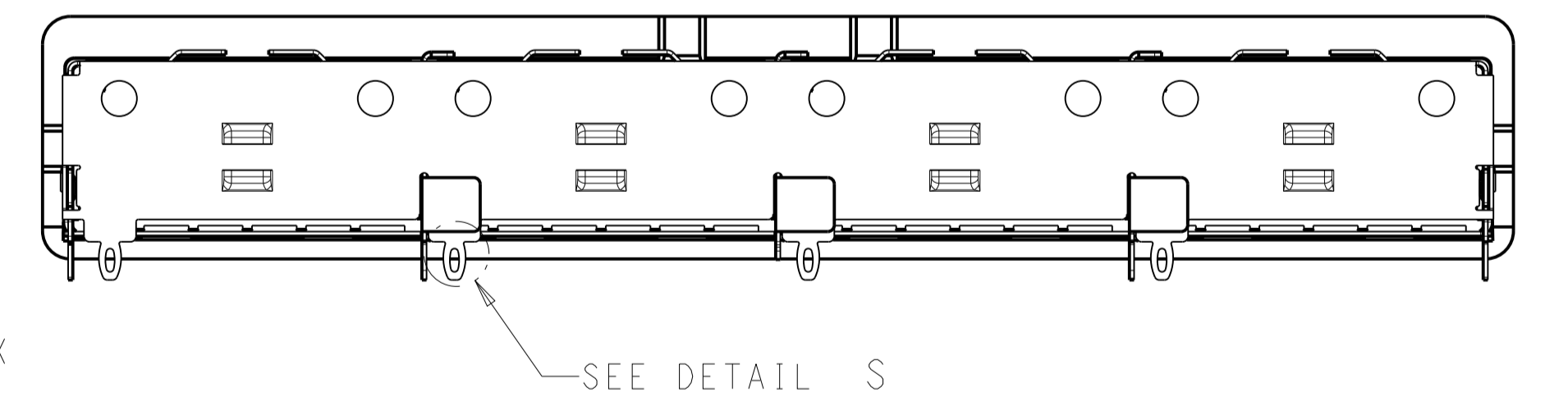
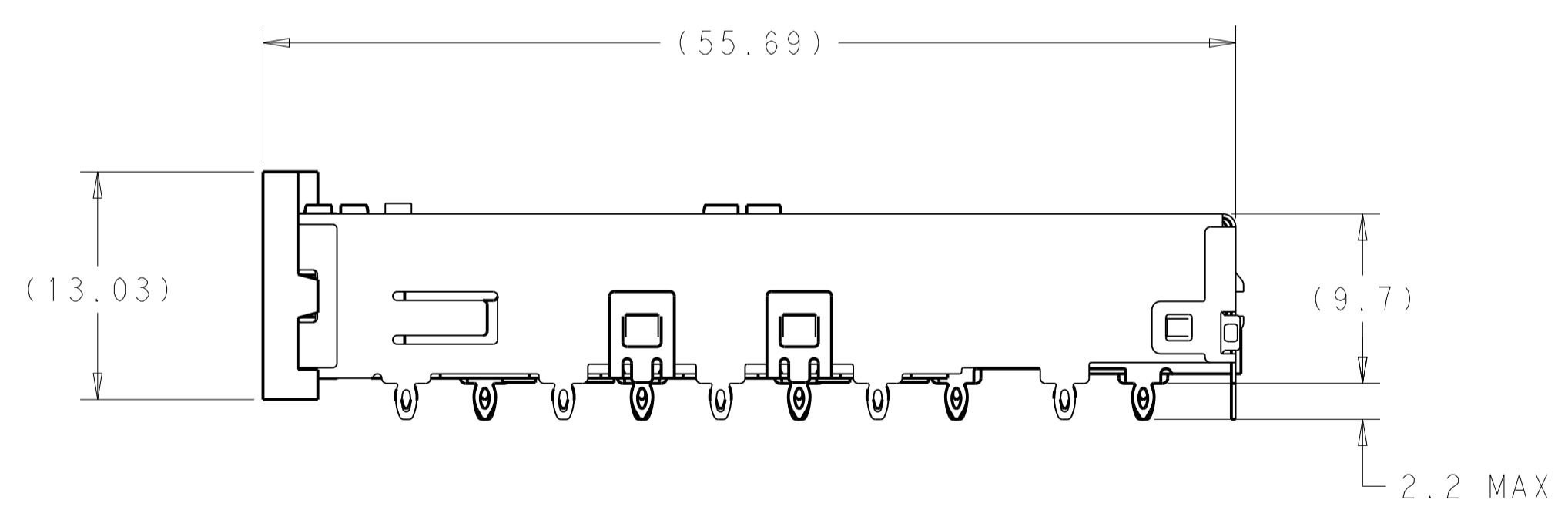
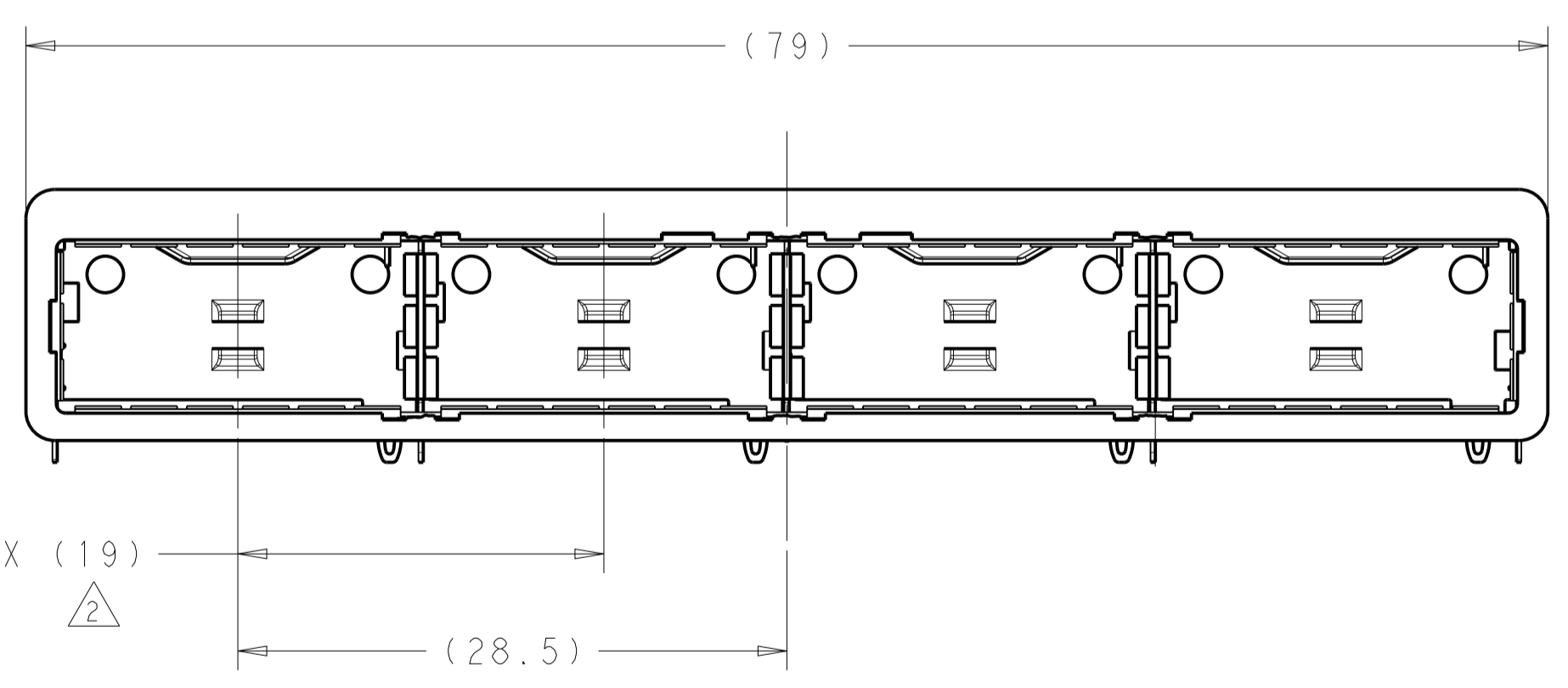

DETAIL S
SCALE 20:1

2227250-1
PART NUMBER

THIS DRAWING IS A CONTROLLED DOCUMENT.		DMN C. VALENTIN 20MAY2014	TE Connectivity	
DIMENSIONS:		CHK E. BRIANT 20MAY2014	NAME CAGE ASSEMBLY, BEHIND BEZEL, 1X4, QSFP28	
TOLERANCES UNLESS OTHERWISE SPECIFIED:		APVD E. BRIANT 20MAY2014	PRODUCT SPEC 108-19428	
mm		0 PLC ±0.1	APPLICATION SPEC 114-32023	
1 PLC ±0.1		1 PLC ±0.1	SIZE A1	
2 PLC ±0.1		2 PLC ±0.1	CAGE CODE C=2227250	
3 PLC ±0.1		3 PLC ±0.1	RESTRICTED TO	
4 PLC ±0.1		4 PLC ±0.1	SCALE 3:1	
ANGLES ±0.1		ANGLES ±0.1	SHEET 1 OF 4	
MATERIAL		FINISH	REV A	
13		14	CUSTOMER DRAWING	

REVISIONS				
P.	LTN	DESCRIPTION	DATE	DWN APVD
-	-	SEE SHEET 1	-	-

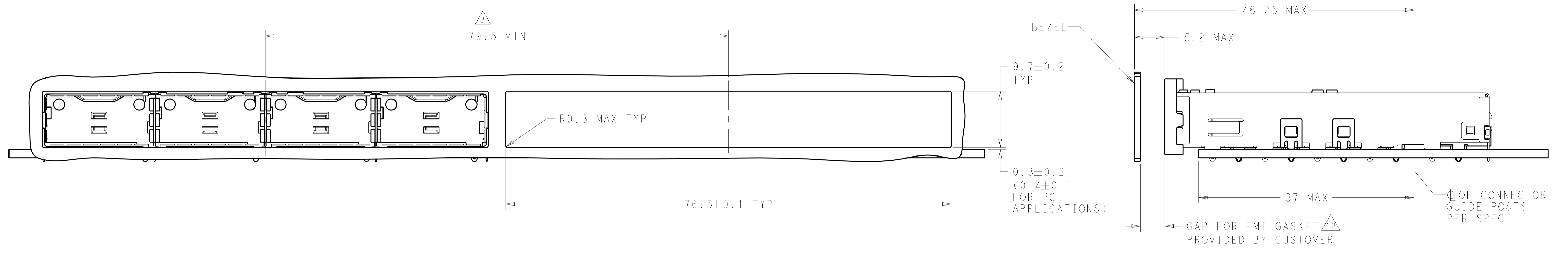

ONE SIDED CONFIGURATION

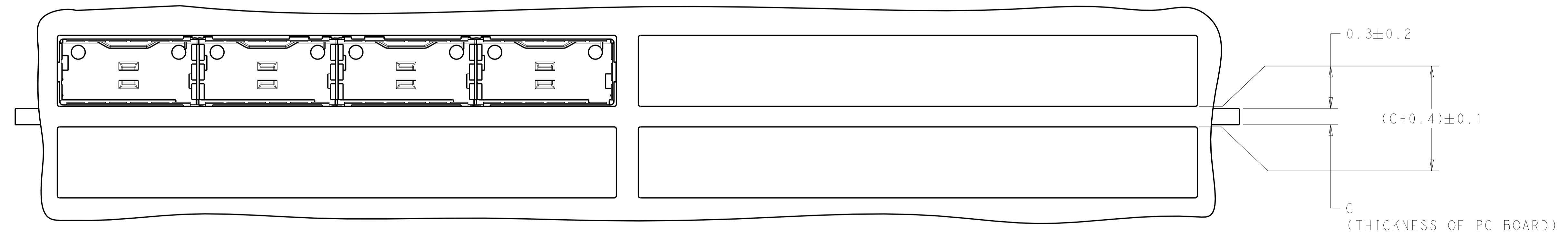

BELLY TO BELLY CONFIGURATION
 SIMILAR TO NOE SIDED
 EXCEPT WHERE NOTED

THIS DRAWING IS A CONTROLLED DOCUMENT.		DWN C. VALENTIN 20MAY2014	TE Connectivity
DIMENSIONS:		CHK E. BRIANT 20MAY2014	
mm	TOLERANCES UNLESS OTHERWISE SPECIFIED:	APVD E. BRIANT 20MAY2014	NAME CAGE ASSEMBLY, BEHIND BEZEL, 1X4, QSFP28
	0 PLC ±0.1 1 PLC ±0.1 2 PLC ±0.1 3 PLC ±0.1 4 PLC ±0.1 ANGLES ±0.1	PRODUCT SPEC 108-19428 APPLICATION SPEC 114-32023	SIZE A1
MATERIAL	FINISH	WEIGHT -	RESTRICTED TO -
CUSTOMER DRAWING		SCALE 3:1	SHEET 2 OF 4
		REV A	

REVISIONS				
REV	DATE	BY	APP'D	DESCRIPTION
-	-	-	-	SEE SHEET 1

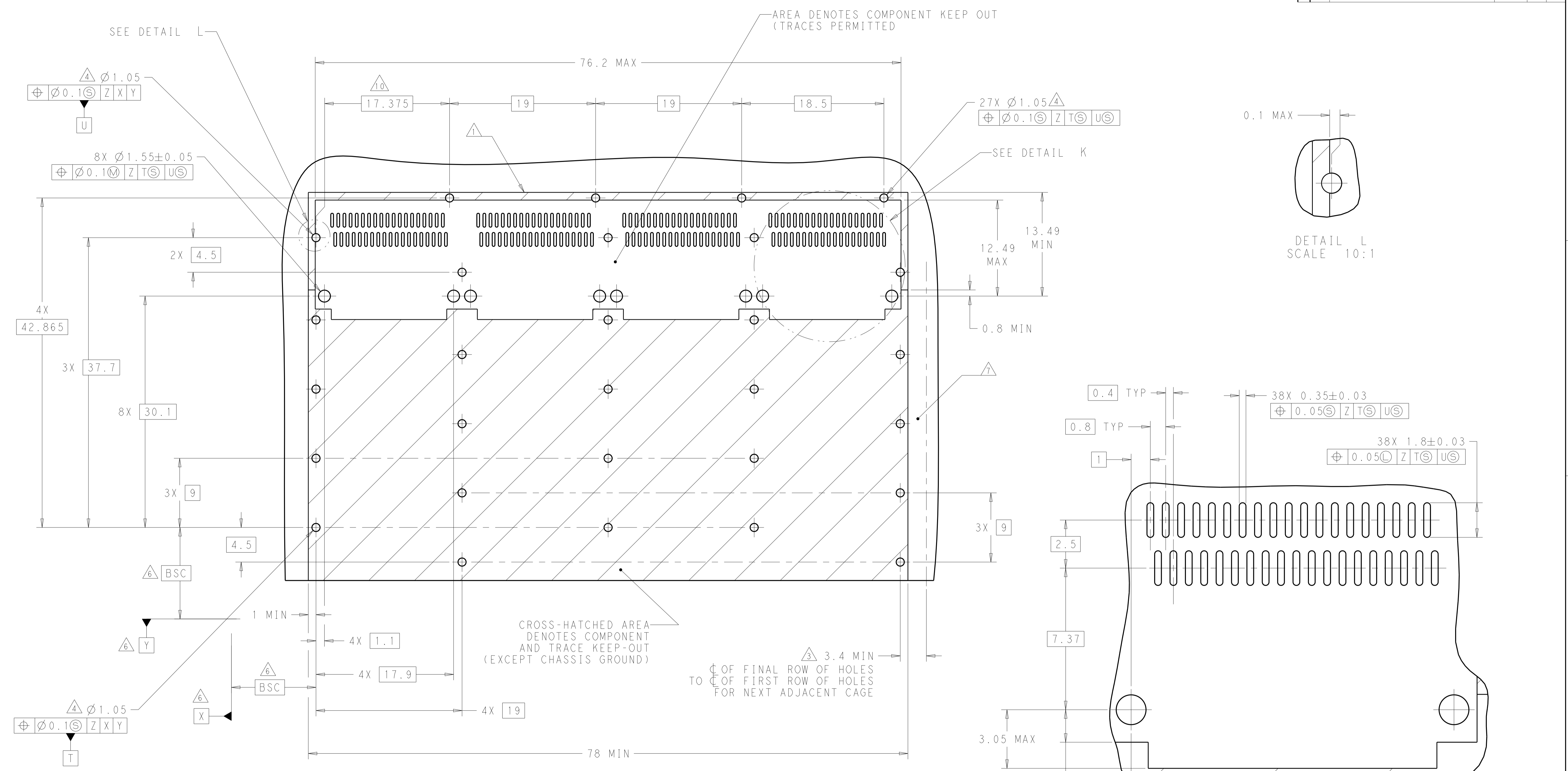

THIS DRAWING IS A CONTROLLED DOCUMENT.		OWN C. VALENTIN 20MAY2014	 TE Connectivity												
DIMENSIONS: mm		CHK E. BRIANT 20MAY2014													
TOLERANCES UNLESS OTHERWISE SPECIFIED:		APVD E. BRIANT 20MAY2014	NAME CAGE ASSEMBLY, BEHIND BEZEL, 1X4, QSFP28												
<table border="1"> <tr> <td>0 PLC</td> <td>± 0.1</td> </tr> <tr> <td>1 PLC</td> <td>± 0.1</td> </tr> <tr> <td>2 PLC</td> <td>± 0.1</td> </tr> <tr> <td>3 PLC</td> <td>± 0.1</td> </tr> <tr> <td>4 PLC</td> <td>± 0.1</td> </tr> <tr> <td>ANGLES</td> <td>± 0.1</td> </tr> </table>		0 PLC	± 0.1	1 PLC	± 0.1	2 PLC	± 0.1	3 PLC	± 0.1	4 PLC	± 0.1	ANGLES	± 0.1	PRODUCT SPEC 108-19428	SIZE A1
0 PLC	± 0.1														
1 PLC	± 0.1														
2 PLC	± 0.1														
3 PLC	± 0.1														
4 PLC	± 0.1														
ANGLES	± 0.1														
MATERIAL		APPLICATION SPEC 114-32023	RESTRICTED TO												
FINISH		WEIGHT	SCALE 3:1 SHEET 3 OF 4 REV A												
CUSTOMER DRAWING		SCALE 3:1													

REVISIONS				
REV	DATE	DESCRIPTION	BY	APPV
-	-	SEE SHEET 1	-	-

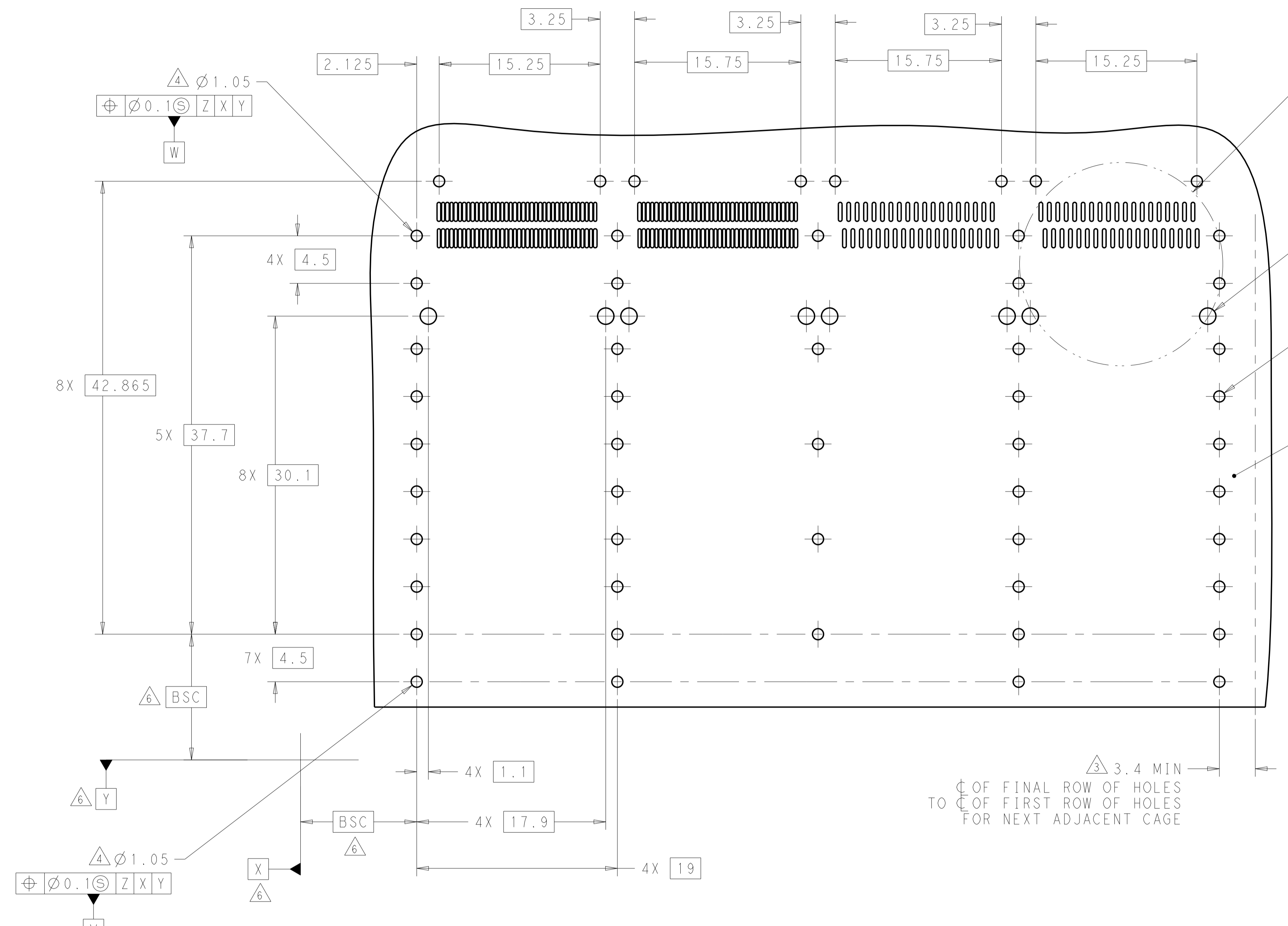

SEE DETAIL M

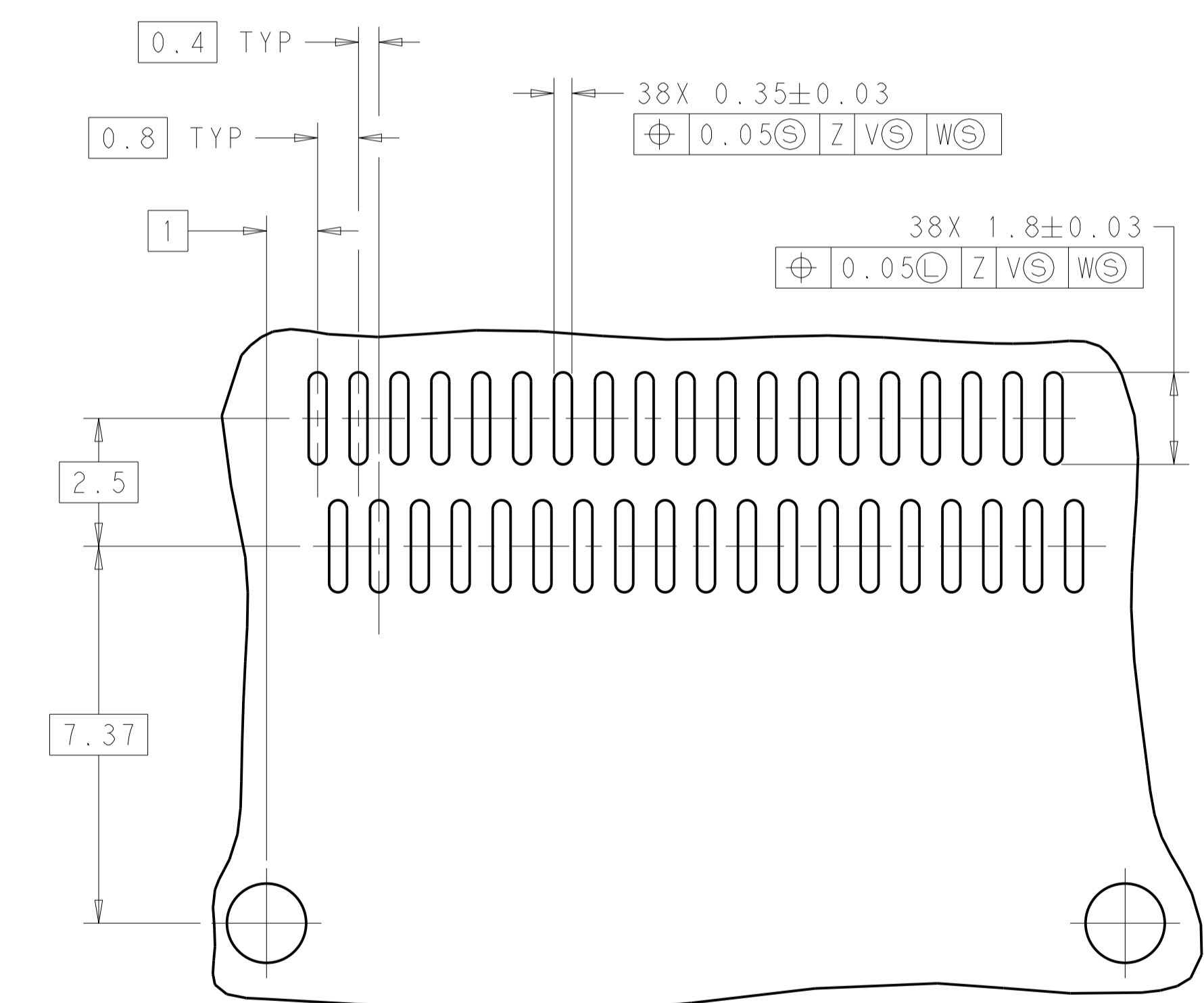

RECOMMENDED PC BOARD LAYOUT
 BELLY TO BELLY CONFIGURATION
 SCALE 4:1

DETAIL M
 4 PLACES
 SCALE 10:1

THIS DRAWING IS A CONTROLLED DOCUMENT.		OWN: C. VALENTIN, ZOMAY2014	TE Connectivity
DIMENSIONS: mm		CHK: E. BRIANT, ZOMAY2014	
TOLERANCES UNLESS OTHERWISE SPECIFIED:		APVD: F. BRIANT, ZOMAY2014	NAME: CAGE ASSEMBLY, BEHIND BEZEL, 1X4, QSFP28
0 PLC ±0.1	1 PLC ±0.1	PRODUCT SPEC: 108-19428	SIZE: A1
2 PLC ±0.1	3 PLC ±0.1	APPLICATION SPEC: 114-32023	SCALE: 3:1
4 PLC ±0.1	ANGLES ±0.1	WEIGHT: -	SHEET 4 OF 4
MATERIAL:	FINISH:	CUSTOMER DRAWING	REV A

单击下面可查看定价，库存，交付和生命周期等信息

[>>TE Connectivity\(泰科\)](#)