

THIS DRAWING IS UNPUBLISHED. RELEASED FOR PUBLICATION
 © COPYRIGHT BY TYCO ELECTRONICS CORPORATION. ALL RIGHTS RESERVED.

LOC	DIST	REVISIONS			
P	LTR	DESCRIPTION	DATE	DWN	APVD
AG	53	01	REVISED PER ECO-08-021128	02SEP08	DH DB

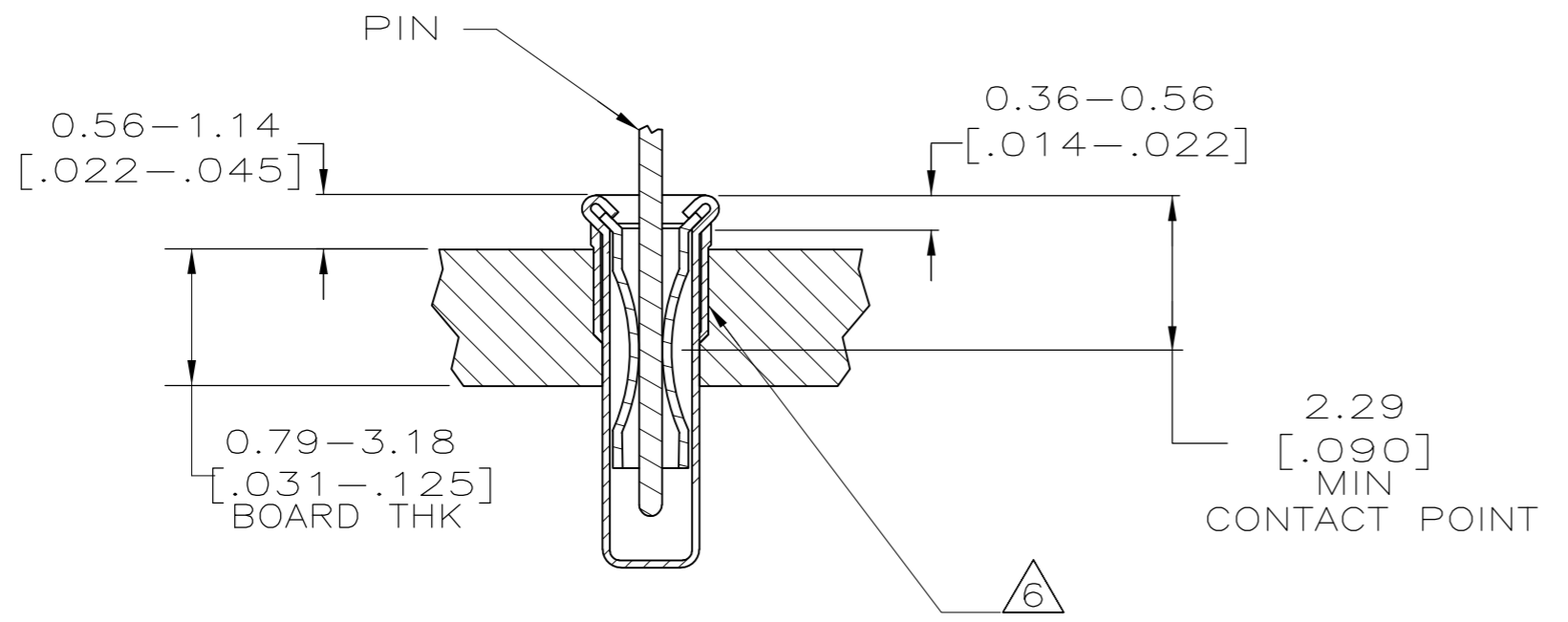
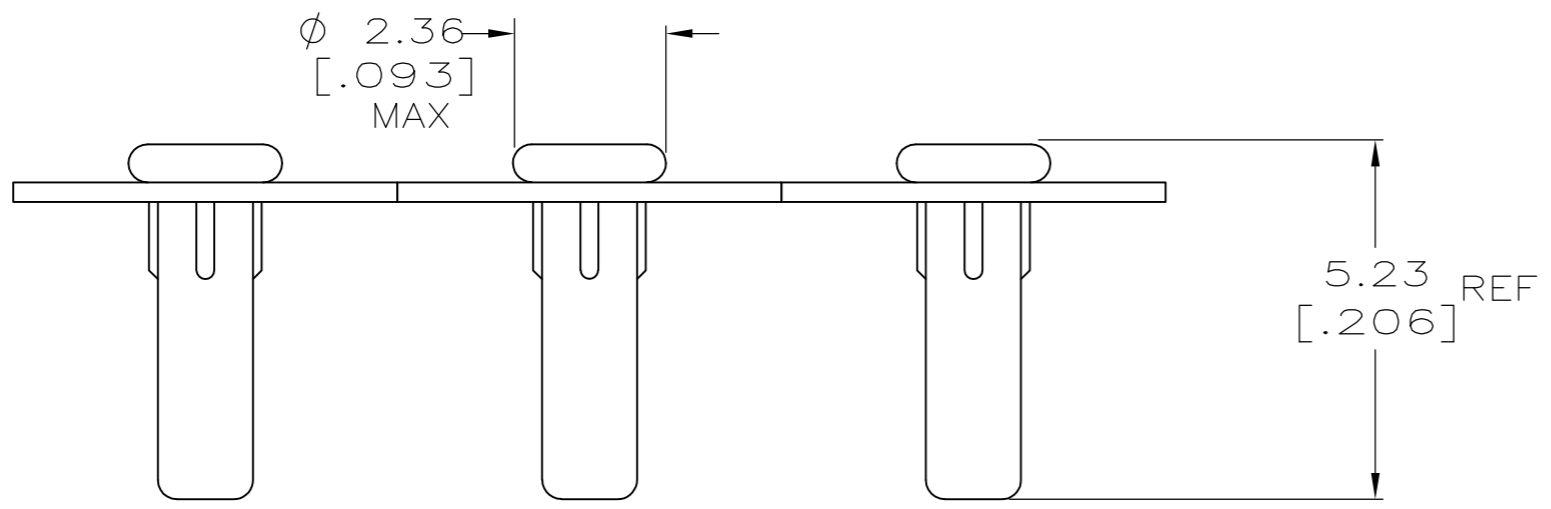
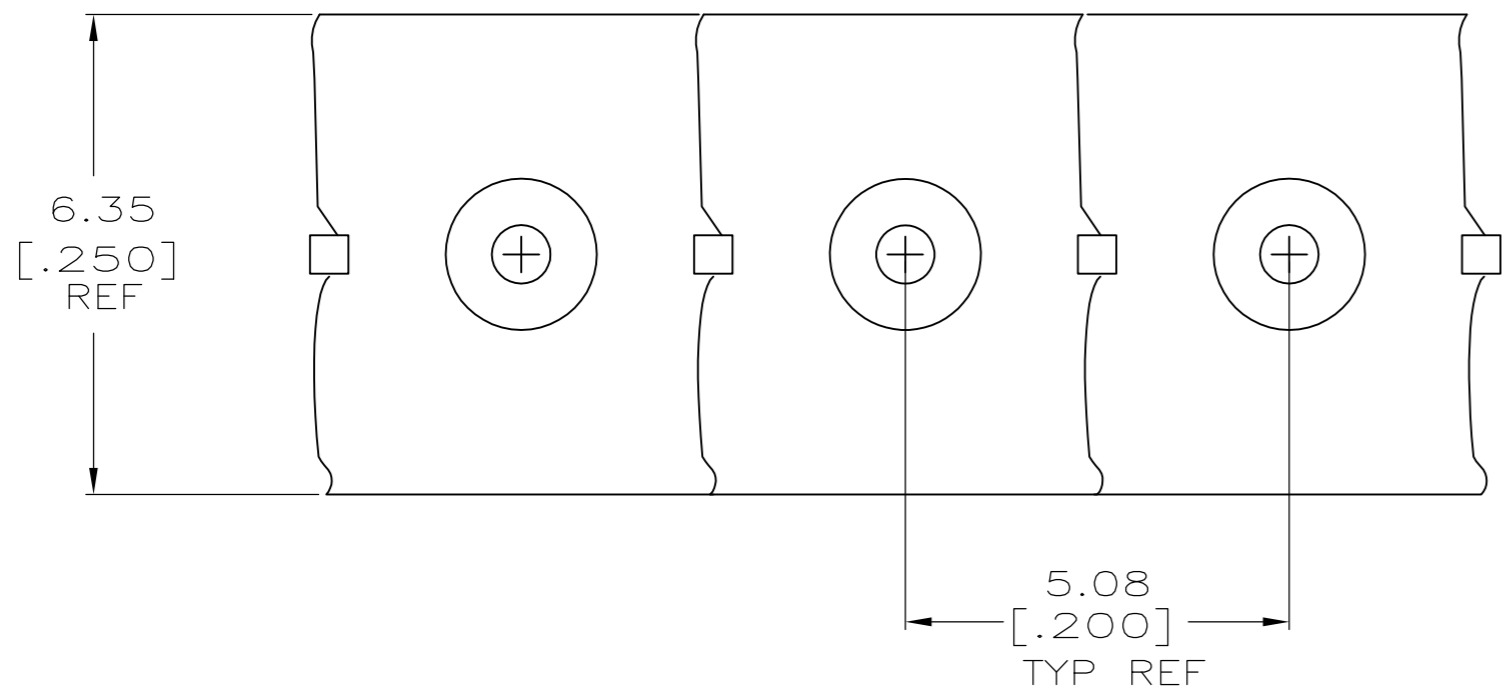

- 1 MATERIAL:
EYELET- COPPER PER ASTM B 152
SPRING- BERYLLIUM-COPPER PER ASTM B 194
- 2 TIN PLATE PER ASTM B 545 0.00254 [.000100] MIN THICK.
- 3 NICKEL UNDERPLATE ALL OVER, MATING SURFACES PLATED TO MEET PERFORMANCE REQUIREMENTS OF TYCO ELECTRONICS PRODUCT SPECIFICATION 108-14008.
- 4. PACKAGE 50,000 PER REEL.
- 5 TO ENSURE 1/2 OZ MIN RETENTION, DO NOT EXCEED 0.05 [.002] DIFFERENCE IN PIN DIA WHEN CHANGING TO A SMALLER DIA PIN.
- 6 SHOULDER ON SOCKET PROVIDES RETENTION IN THE P.C. BOARD. THE RECOMMENDED HOLE DIAMETER IS $\phi 1.91 [\phi .075]$ MINIMUM, + 0.08 [.003] MAXIMUM PRIOR TO SOLDERING.

0.96-1.07 [.038-.042]	3	2	5645518-1
PIN DIA	5	SPRING EYELET FINISH	PART NUMBER

THIS DRAWING IS A CONTROLLED DOCUMENT.		DWN	100CT2005	Tyco Electronics Corporation Harrisburg, PA 17105-3608
DIMENSIONS: mm [INCHES]		CHK	100CT2005	
TOLERANCES UNLESS OTHERWISE SPECIFIED:		APVD	100CT2005	
0 PLC ± - 1 PLC ± - 2 PLC ± - 3 PLC ± 0.20 [.008] 4 PLC ± - ANGLES ± -		NAME	J. HAVENER	
MATERIAL		PRODUCT SPEC	108-14008	MINIATURE SPRING SOCKET ASSY SERIES 4
FINISH		APPLICATION SPEC	114-26004	SIZE
SEE TABLE		WEIGHT	-	CAGE CODE
		CUSTOMER DRAWING		00779
		SCALE	10:1	DRAWING NO
		SHEET	1 of 1	RESTRICTED TO
		REV	01	

5645518

单击下面可查看定价，库存，交付和生命周期等信息

[>>TE Connectivity\(泰科\)](#)