

LOC		DIST		REVISIONS			
DF	DO	P	L/R	DESCRIPTION	DATE	DN	APVD
		P		REV PER ECO-07-002868	20FEB07	PY	ND

1. THIS PLUG WILL MATE WITH ANY 104 POSN., SIZE 6 RECEPTACLE IN AMPLIMITE SERIES.
  2. SST RETENTION CLIPS ARE INCLUDED IN INSERTS.
  3. THIS PLUG IS DESIGNED TO CONFORM TO THE LATEST ISSUE OF MIL-C-24308.
  4. REPLACEMENT CONTACT P/N 1-207683-2
  5. TO INSTALL OR REMOVE CONTACTS USE INSERTION/EXTRACTION TOOL P/N 91067-1 OR MIL NUMBER M81969/1-04.
- 6 AS SHOWN EXCEPT WITH .120 DIAMETER MOUNTING HOLES IN PLACE OF CLINCH NUTS  
 7 SOLDER DIP PER MIL-STD-2000 COMPOSITION Sn63 CONFORMING TO QQ-S-571. COVERAGE SHALL BE COMPLETE TO A DISTANCE OF .030 MAX. FROM REAR INSERT.  
 8 DIMENSION APPLIES PRIOR TO SOLDER DIPPING. ALLOW ADDITIONAL .030 POST PROJECTION AFTER SOLDER DIPPING.  
 9 CLINCH NUT PROVIDED ON 213045-1 ONLY.

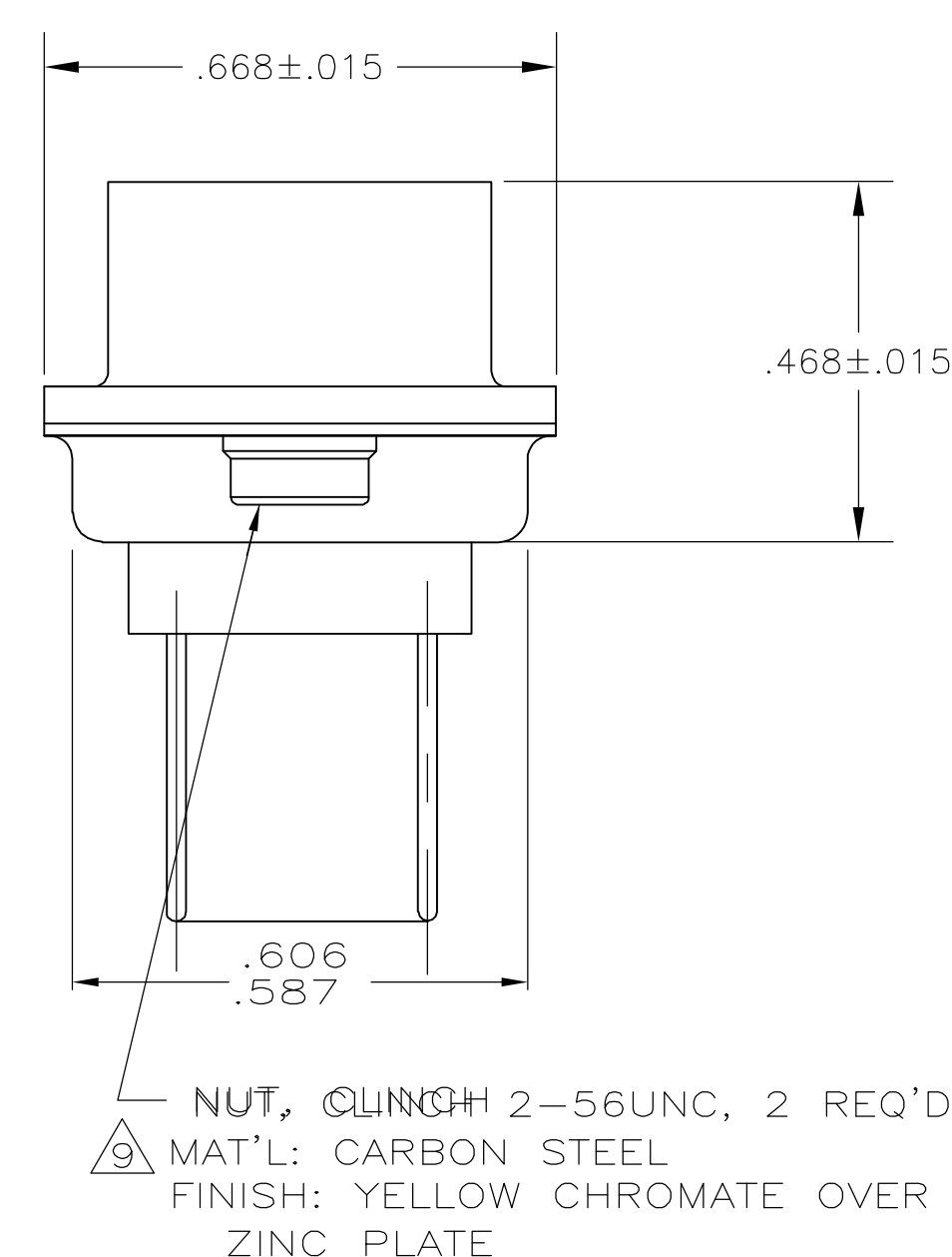
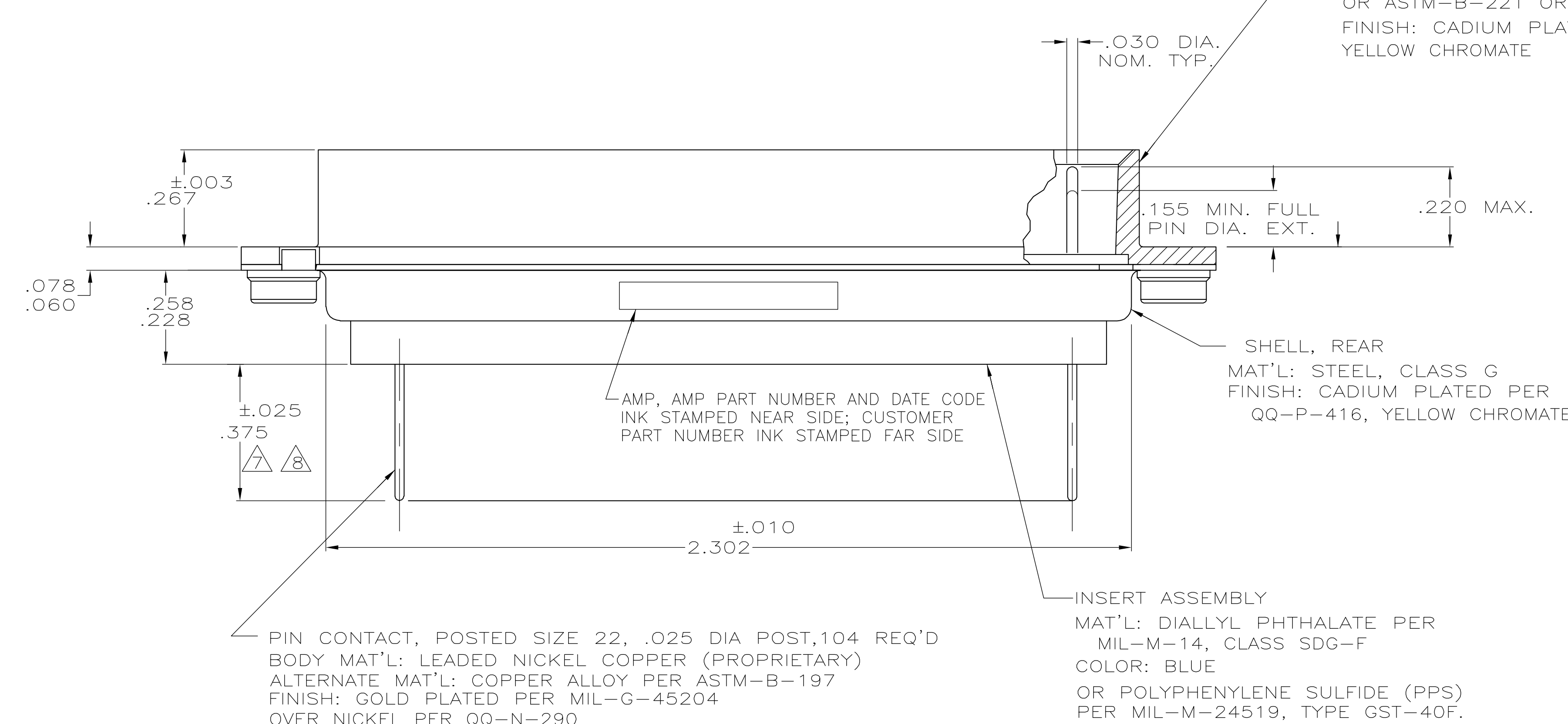
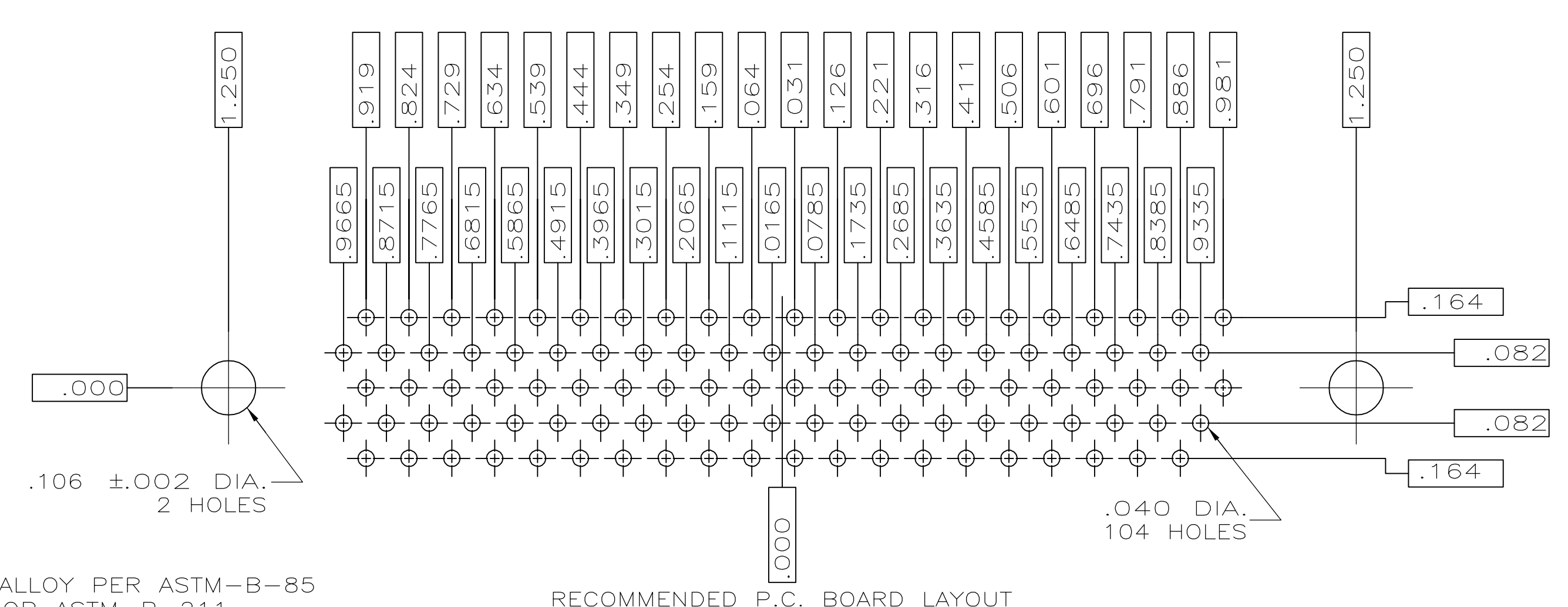
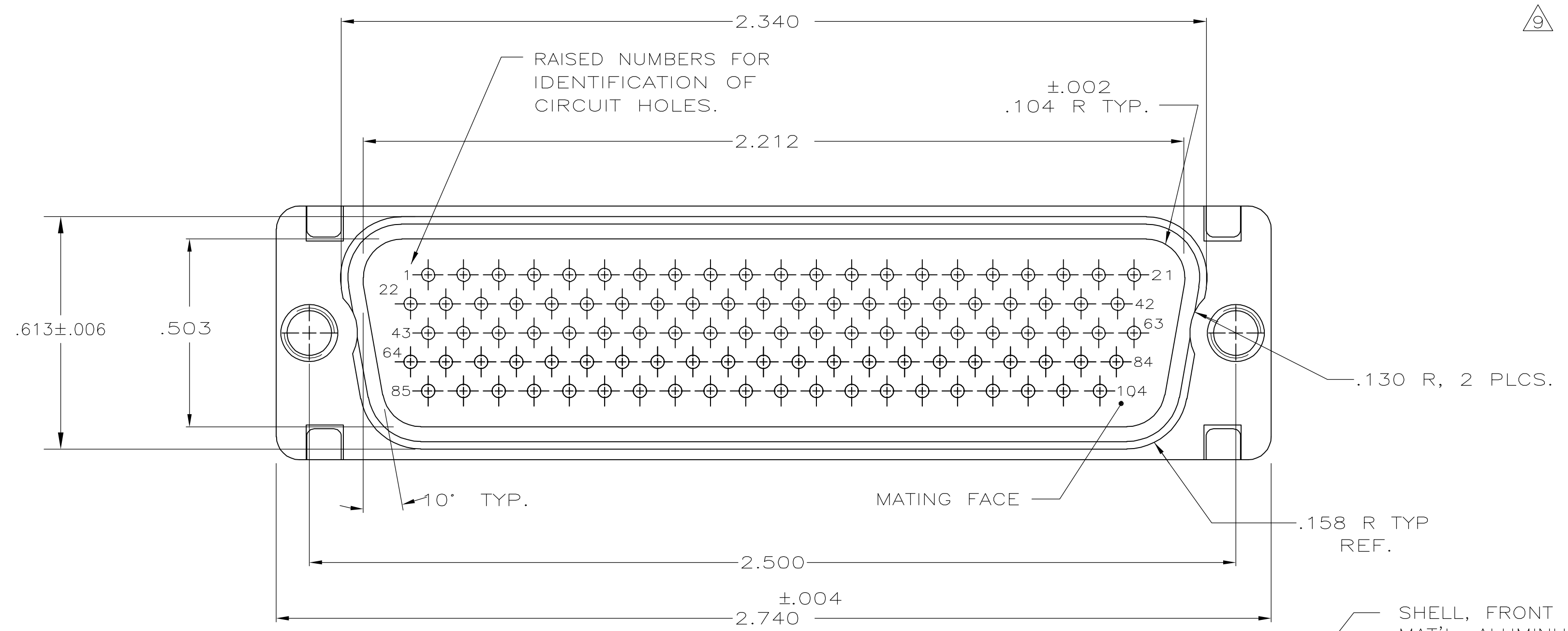

AS SHOWN	213045-2
DESCRIPTION	PART NO

THIS DRAWING IS A CONTROLLED DOCUMENT.		DIN	J.A. Baker	05-08-95		Tyco Electronics Corporation Harrisburg, PA 17105-3608	
DIMENSIONS: INCHES		CHK	F. KINSEY	05-08-95		NAME	PLUG ASS'Y, AMPLIMITE, 104 POSN., SIZE 6, SERIES 90, BLINDMATE, POSTED
TOLERANCES UNLESS OTHERWISE SPECIFIED:		APVD	F. KINSEY	05-08-95	PRODUCT SPEC	SIZE	
0 PLC	± -	APPLICATION SPEC	F. KINSEY		WEIGHT	A1 00779 C=213045	
1 PLC	± -	MATERIAL		FINISH	CUSTOMER DRAWING		
2 PLC	± -	SCALE		1:1	SHEET 1 of 1		
3 PLC	± .005	RESTRICTED TO		REV P			
4 PLC	± -						
ANGLES	± 0° 30'						

单击下面可查看定价，库存，交付和生命周期等信息

[>>TE Connectivity\(泰科\)](#)