

THIS DRAWING IS UNPUBLISHED. RELEASED FOR PUBLICATION
 © COPYRIGHT BY TYCO ELECTRONICS CORPORATION. ALL RIGHTS RESERVED.

LOC	DIST	REVISIONS			
P	LTR	DESCRIPTION	DATE	DWN	APVD
AJ	16	J	REVISED PER EC 0124-0456-04	13DEC05	BL JL

1. USE INSTRUCTION SHEET 9821

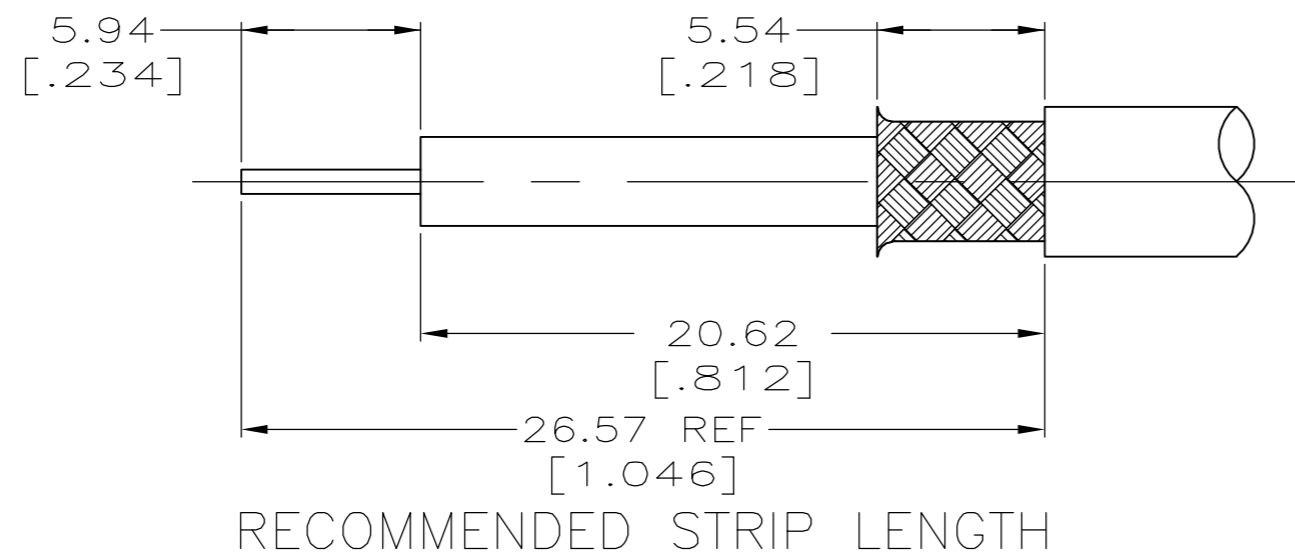
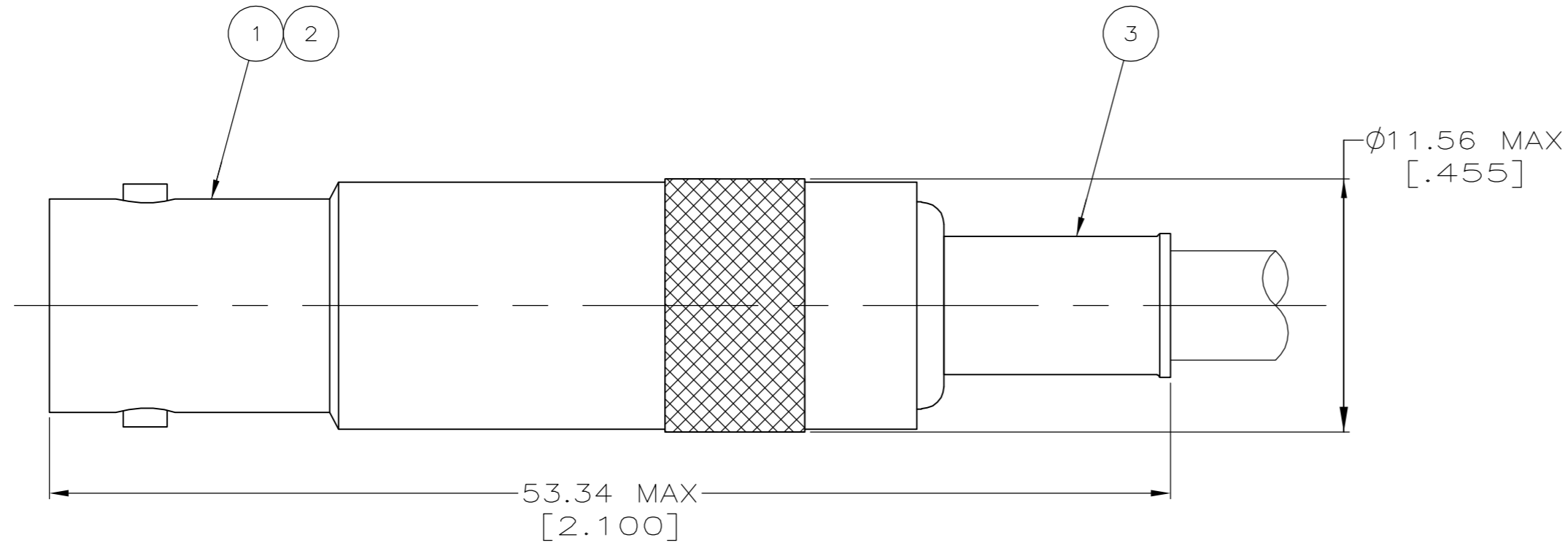

OBSOLETE	CONSOLIDATED RG-59A/U	220022-2	9-50428-1	225057-2	225096-4	225087-7
OBSOLETE	RG-71/U	220022-2	1-329460-1	225057-2	225096-4	225087-6
	RG-59/U, 59A/U, 59B/U, 62/U, 62A/U, 62B/U	220022-2	9-50428-0	225057-2	225096-4	225087-5
OBSOLETE	RG-58A/U, 58C/U	220022-1	9-50427-1	225056-2	225096-3	225087-4
OBSOLETE	RG-71/U	220022-2	329460	225057-2	225096-2	225087-3
SUPERSEDED BY 225087-5	RG-59/U, 59A/U, 59B/U, 62/U, 62A/U, 62B/U	220022-2	50428-1	225057-2	225096-2	225087-2
SUPERSEDED BY 225087-4	RG-58A/U, 58C/U	220022-1	50427-1	225056-2	225096-1	225087-1

FOR USE WITH CABLE	HAND TOOL	③ FERRULE QTY=1	② CONTACT QTY=1	① JACK ASSEMBLY QTY=1	PART NUMBER
--------------------	-----------	--------------------	--------------------	--------------------------	-------------

THIS DRAWING IS A CONTROLLED DOCUMENT.

DWN	M. E. COWHER	3-2-93
CHK	M. PHILLIPS	3-3-93
APVD	M. PHILLIPS	3-3-93

tyco Electronics
 Tyco Electronics Corporation
 Harrisburg, PA 17105-3608

NAME: JACK, STANDARD HIGH VOLTAGE

SIZE	CAGE CODE	DRAWING NO	RESTRICTED TO
A2	00779	C=225087	-

SCALE: 1:1 SHEET: 1 of 1 REV: J

CUSTOMER DRAWING

单击下面可查看定价，库存，交付和生命周期等信息

[>>TE Connectivity\(泰科\)](#)