

© 1966 BY AMP INCORPORATED. ALL RIGHTS RESERVED. AMP PRODUCTS COVERED BY PATENTS AND/OR PATENTS PENDING. APPROVED PER GOVT CONTRACT NO.

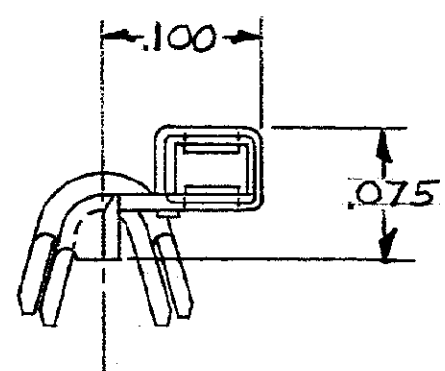
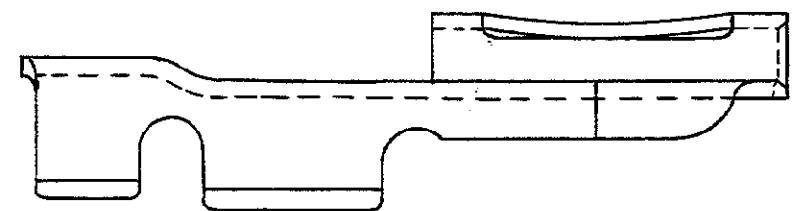
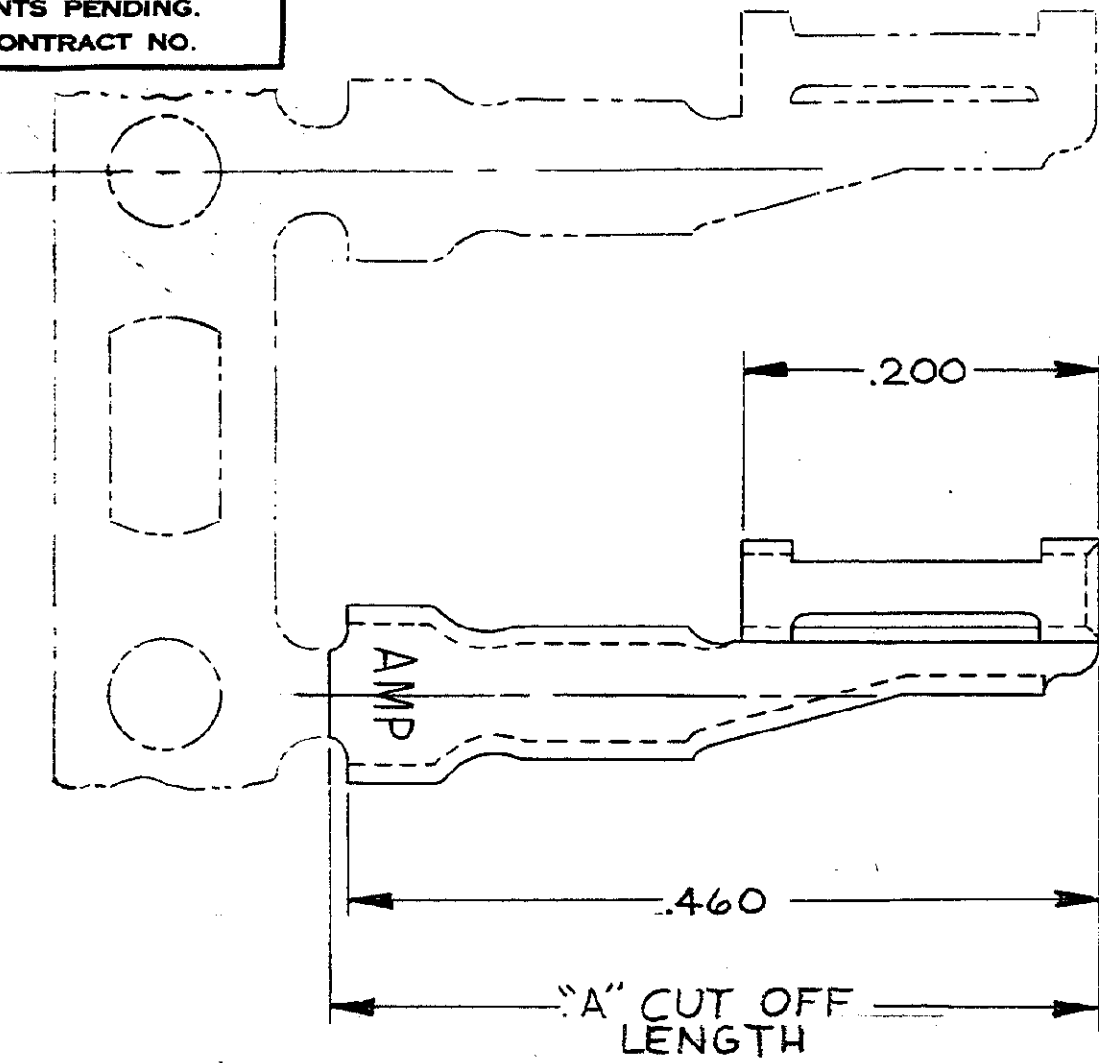

REVISIONS				
ZONE	LTR	DESCRIPTION	DATE	APPROVED
	0	PER N.P.S. 66-1956 Rev 1	FY 11/26/66	RHW
	A	ADDED -1 & -2 PER NPS 7-14089 & ECN TPC 0336	2/7/67	RHW
	B	TP-0544 (WIRE SIZE, R CHANGED) TPC-0532		
	C	ADDED 67263-3, NPS 8-14001	1-30-68	GS
	D	PER T.P. 1489 (WIRE SIZE CHANGED)	1-8-70	FNN
	E	REV. PER WP2782	11-26-74	PY
	F	REV PER ADO053	12-27-83	GS
	F	OBSOLETE -3 PER AD1126	2/19/86	GS

**OBSOLETE**

REEL STYLE	QTY	NOMENCLATURE OR DESCRIPTION	PART OR IDENTIFYING NO.	FINISH
"A"	1	CRIMP ON RECP'E	67263-2	GOLD # .000010 MIN (MIL-G-45204) TYPE II (.000030 MIN ON RECEPTACLE END), ALL OVER NICKEL # .000030 MIN (QQ-N-290).
	1		67263-1	

OPTIONAL POST APPLIED INSULATION  
HEAT SHRINKABLE TUBING P/N 67279-1  
(COVERS WIRE & INSULATION BARRELS ONLY)

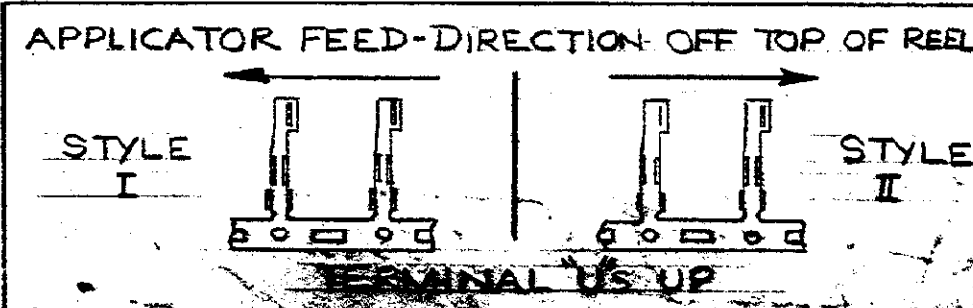

UNLESS OTHERWISE SPECIFIED DIMENSIONS ARE IN INCHES TOLERANCES ON		CONTRACT NO. #		AMP INCORPORATED HARRISBURG, PENNSYLVANIA	
FRACTIONS ± 1/64	DECIMALS ± .008	ANGLES ± 5°	DR. <i>R. J. Hoffman</i>	DATE 10-27-66	NAME
MATERIAL PHOSPHOR BRONZE (QQ-P-750) .010 THK			CHK. <i>R. J. Hoffman</i>	DATE 11/26/66	CRIMP ON RECEPTACLE WIRE SIZE 26-20 .022 X .040 POST .100 X .150 GRID
HEAT TREAT			APPRO. <i>Swabel</i>	DATE 11-23-66	SIZE CODE & PART NO. 00779
FINISH			DSGN APPD	NUMBER 67263	
			OTHER APPD		

NUMBER 67263

CUSTOMER DRAWING

单击下面可查看定价，库存，交付和生命周期等信息

[>>TE Connectivity\(泰科\)](#)