

THIS DRAWING IS UNPUBLISHED. RELEASED FOR PUBLICATION
 © COPYRIGHT BY TYCO ELECTRONICS CORPORATION. ALL INTERNATIONAL RIGHTS RESERVED.

| LOC | DIST | REVISIONS | | | |
|-----|------|-----------------------|---------|-----|------|
| P | LTR | DESCRIPTION | DATE | DWN | APVD |
| G | 14 | REV PER ECR 10-000722 | 22JAN10 | JR | TM |

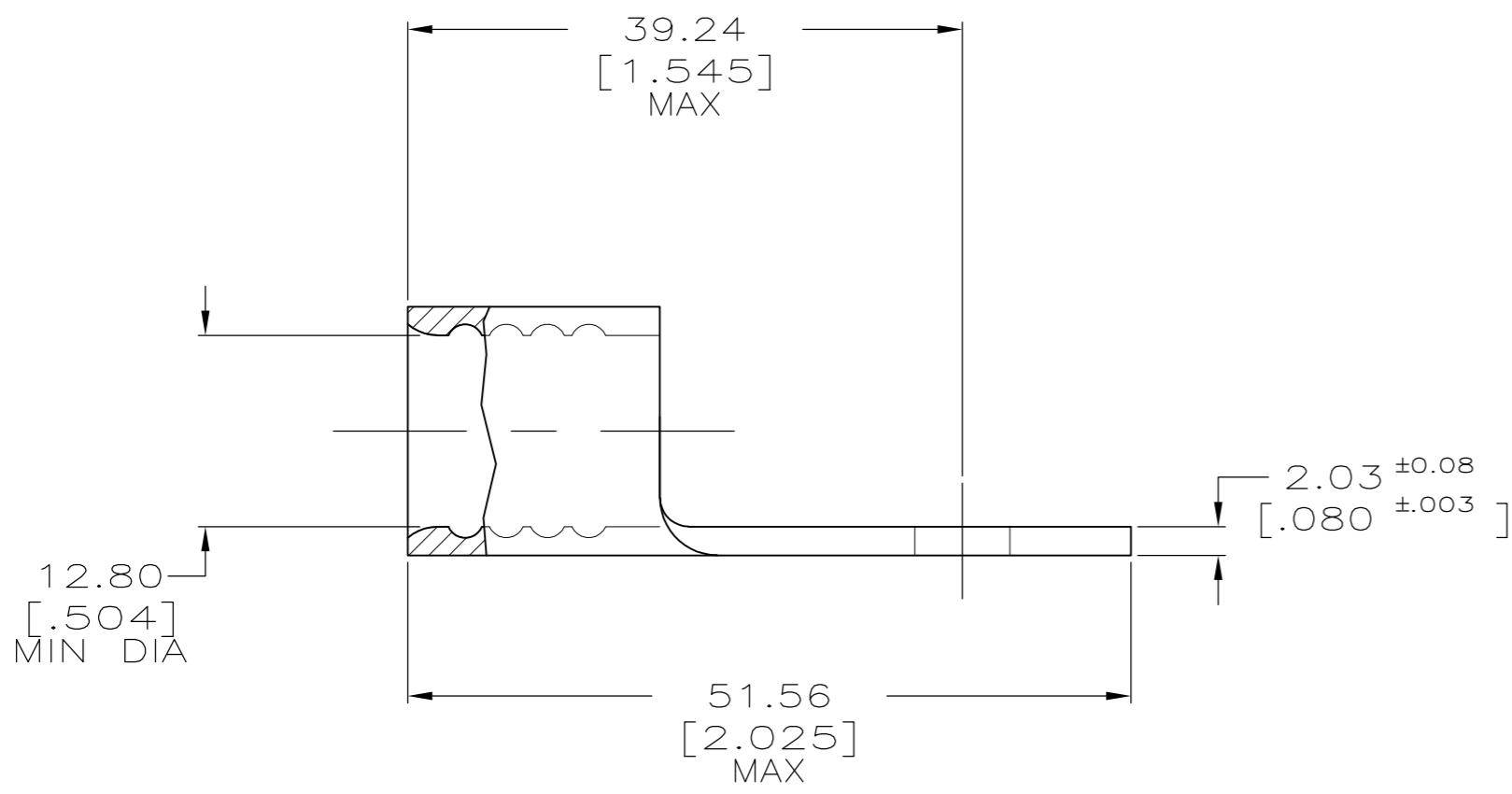
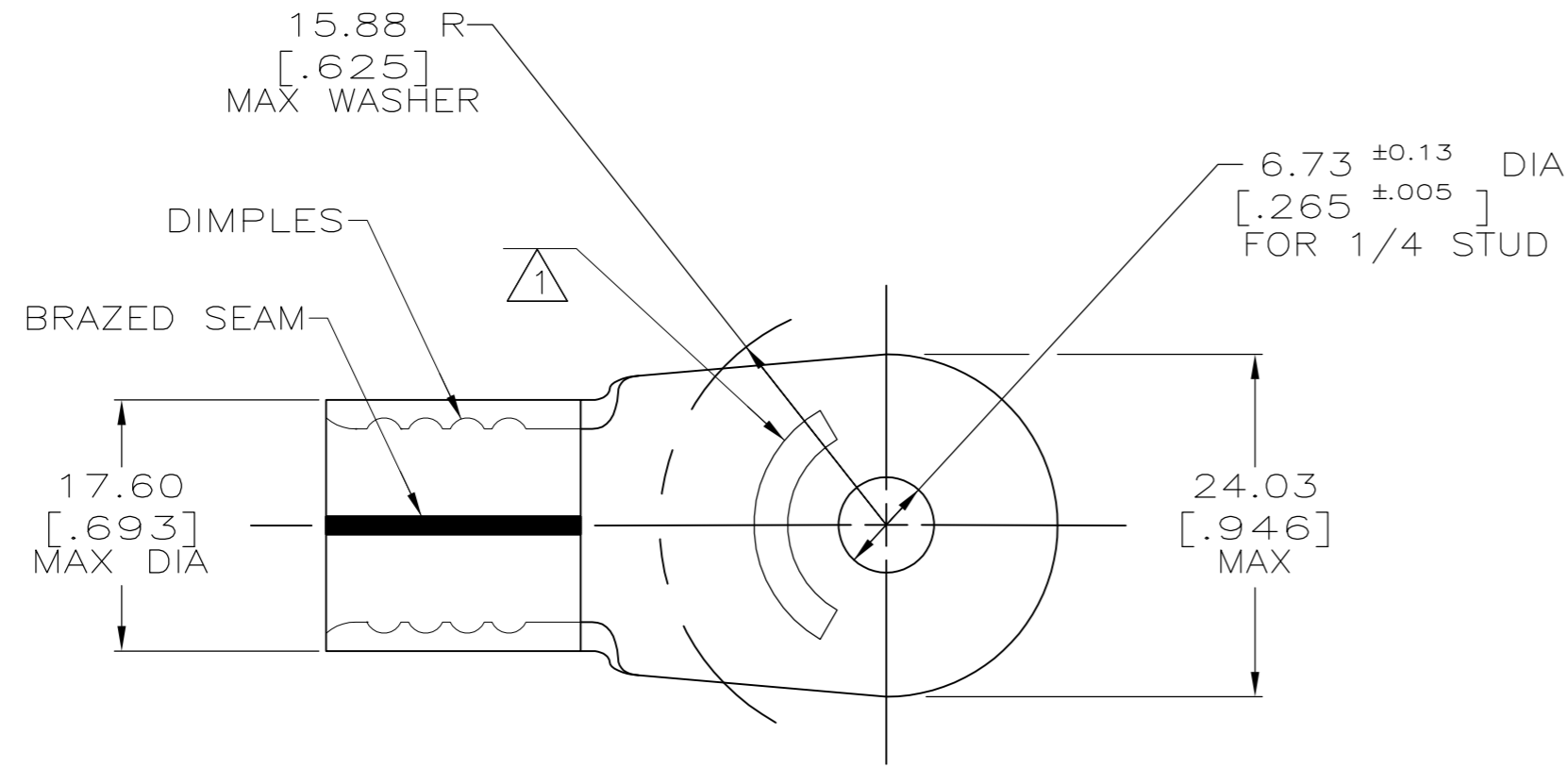

| | | |
|------------------------------|---------------------|------------------------------|
| AMP WIRE RANGE | E13288 Listed | LR7189 Certified |
| 2/0 AWG SOLID OR STRANDED | 2/0 AWG STRANDED | 2/0 AWG SOLID OR STRANDED |

- 1 STAMP AMP 2/0W* APPROX AS SHOWN
- 2 COPPER PER ASTM B-152, ANNEALED
- 3 TIN PLATE 0.00254 [.000100] MIN THK EXT. PER ASTM B-545
- 4 MAX RECOMMENDED OPERATING TEMP IS 170°C.
- 5 WIRE CROSS SECTIONAL AREA RANGE: 60.6-76.3mm [119,500-150,500] CMA SOLID OR STRANDED.

| | | |
|-----|----------------|----------|
| 50 | LOOSE PIECE | 36921 |
| QTY | PACKAGING TYPE | PART NO. |

| | | | | |
|--|--|-------------------------|---|-----------------|
| THIS DRAWING IS A CONTROLLED DOCUMENT. | | DWN DK SCHRUM 1/13/94 | Tyco Electronics Corporation Harrisburg, PA 17105-3608 | |
| DIMENSIONS: INCHES | | CHK AJ KAUFMAN 1/19/94 | | |
| TOLERANCES UNLESS OTHERWISE SPECIFIED: | | APVD JL MECKLEY 1/19/94 | NAME | |
| 0 PLC ± - 1 PLC ± - 2 PLC ± 0.20[.008] 3 PLC ± - 4 PLC ± - ANGLES ± - | | PRODUCT SPEC | TERMINAL, RING TONGUE, SOLISTRAND | |
| MATERIAL | | APPLICATION SPEC | SIZE A2 | CAGE CODE 00779 |
| FINISH | | WEIGHT - | DRAWING NO C=36921 | RESTRICTED TO - |
| CUSTOMER DRAWING | | SCALE 2:1 | SHEET 1 of 1 | REV G |

单击下面可查看定价，库存，交付和生命周期等信息

[>>TE Connectivity\(泰科\)](#)