

REVISIONS			
REV	DESCRIPTION	DATE	APPROVED
01	RELEASED	NC 7/21/95	<i>PCW</i> 7/28/95

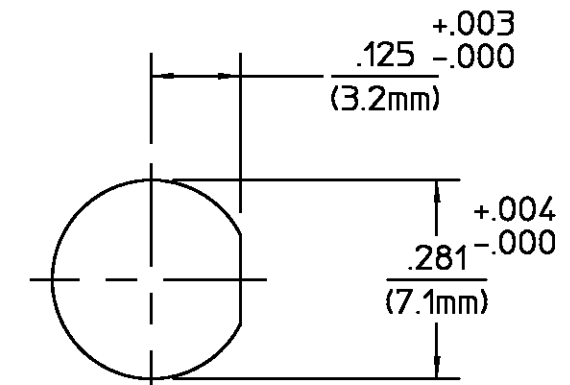
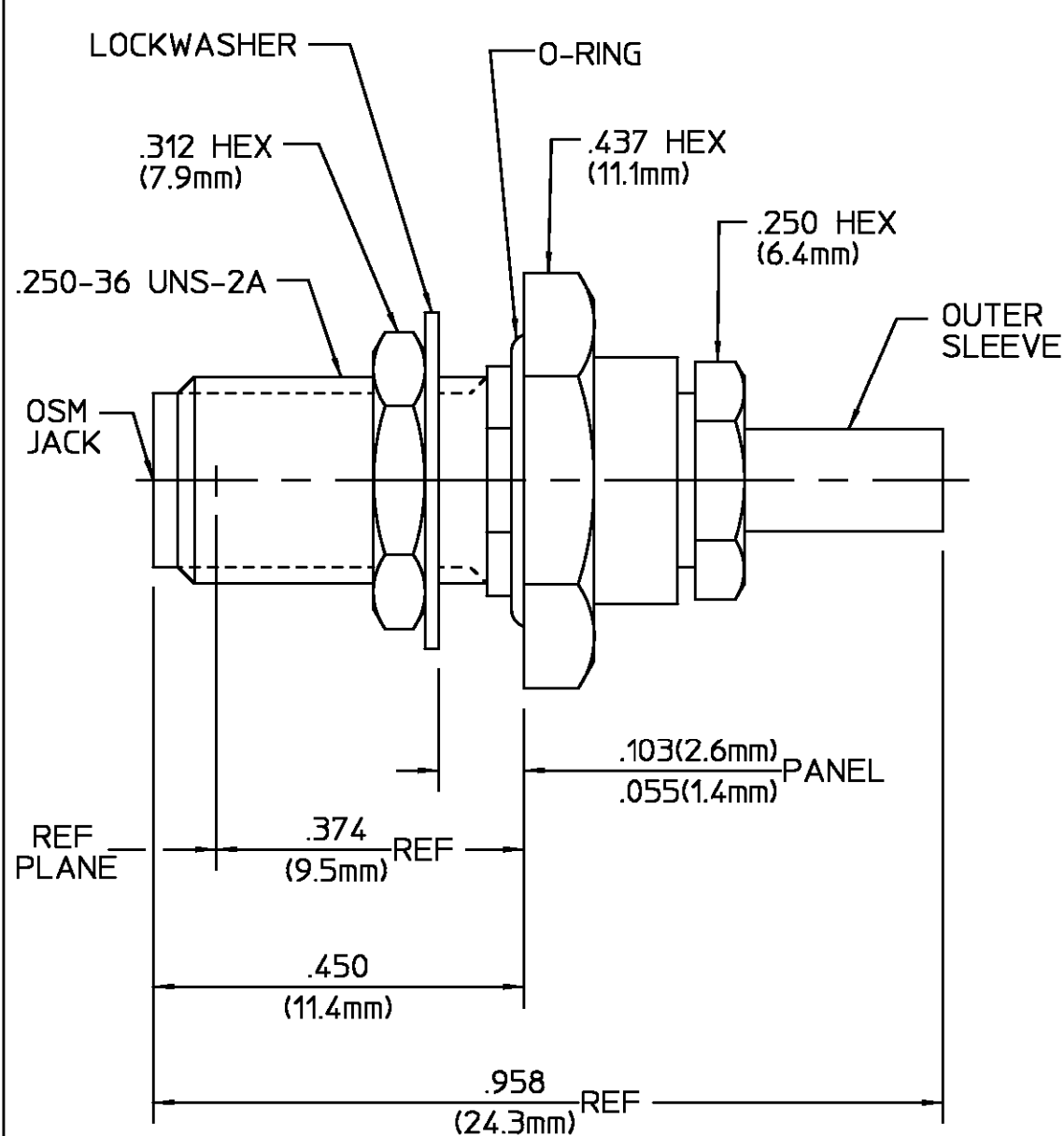

RECOMMENDED MOUNTING HOLE

COMPONENT	MATERIAL	FINISH
HOUSING CLAMP NUT MOUNTING NUT LOCKWASHER	STAINLESS STEEL PER ASTM-A484 AND ASTM- A582, TYPE 303	PASSIVATE PER ASTM A380
SLEEVE	STAINLESS STEEL PER ASTM-A484 AND ASTM- A582, TYPE 303	GOLD PLATE PER MIL-G-45204
DIELECTRIC	TFE FLUOROCARBON PER MIL-P-19468 AND FED SPEC L-P-403	N/A
DIELECTRIC	NYLON	N/A
CENTER CONTACT	BERYLLIUM COPPER PER QQ-C-530, ALLOY 173	GOLD PLATE PER MIL-G-45204
FERRULE	SOFT COPPER ALLOY	GOLD PLATE PER MIL-G-45204
O-RING	SILICONE RUBBER PER ZZ-R-765	N/A

CABLE ENTRY DIAMETER MINIMUM	
FERRULE	.099
SLEEVE	.036
DIELECTRIC	.021
CONTACT	.021

UNLESS OTHERWISE SPECIFIED
DIMENSIONS ARE IN INCHES
TOLERANCE ON
FRAC. DEC. ANGLES
± 1/64 ± .005 ± °

These drawings and specifications are the property of
M/A COM Incorporated and shall
not be reproduced or copied or
used in whole or in part as the
basis for the manufacture or
sale of item(s) without written
permission.

DRAWN BY <i>N. CARTER</i>	DATE 07/21/95	AMP Incorporated 140 Fourth Avenue Waltham, MA 02451-7599	
CHECKED BY		AMP	
APP'D BY <i>PCW</i>	7/28/95		
USE ASS'Y PROCEDURE		TITLE SMA BULKHEAD FEEDTHRU CABLE JACK CRIMP ATTACH. M39012/59-3025 CAT.C	
408-04924 NO. AP. (20-538)		SIZE B	CODE IDENT NO. 26805
		2034-8025-92	
		SCALE 5:1	REV 01
		SHEET 1 OF 1	

- NOTES:
- DESIGNED FOR USE WITH RG-178/U CABLE
 - CAPTURED CENTER CONTACT

单击下面可查看定价，库存，交付和生命周期等信息

[>>TE Connectivity\(泰科\)](#)