

THIS DRAWING IS UNPUBLISHED. RELEASED FOR PUBLICATION
 © COPYRIGHT - By - ALL RIGHTS RESERVED.

LOC	DIST	REVISIONS			
P	LTR	DESCRIPTION	DATE	DWN	APVD
CM	00	K1	REVISED PER ECO-11-014117	12JUL11	HMR SM

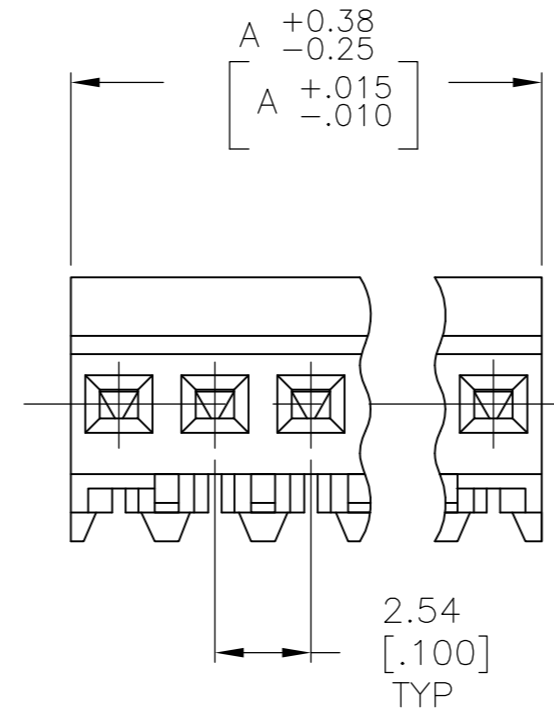
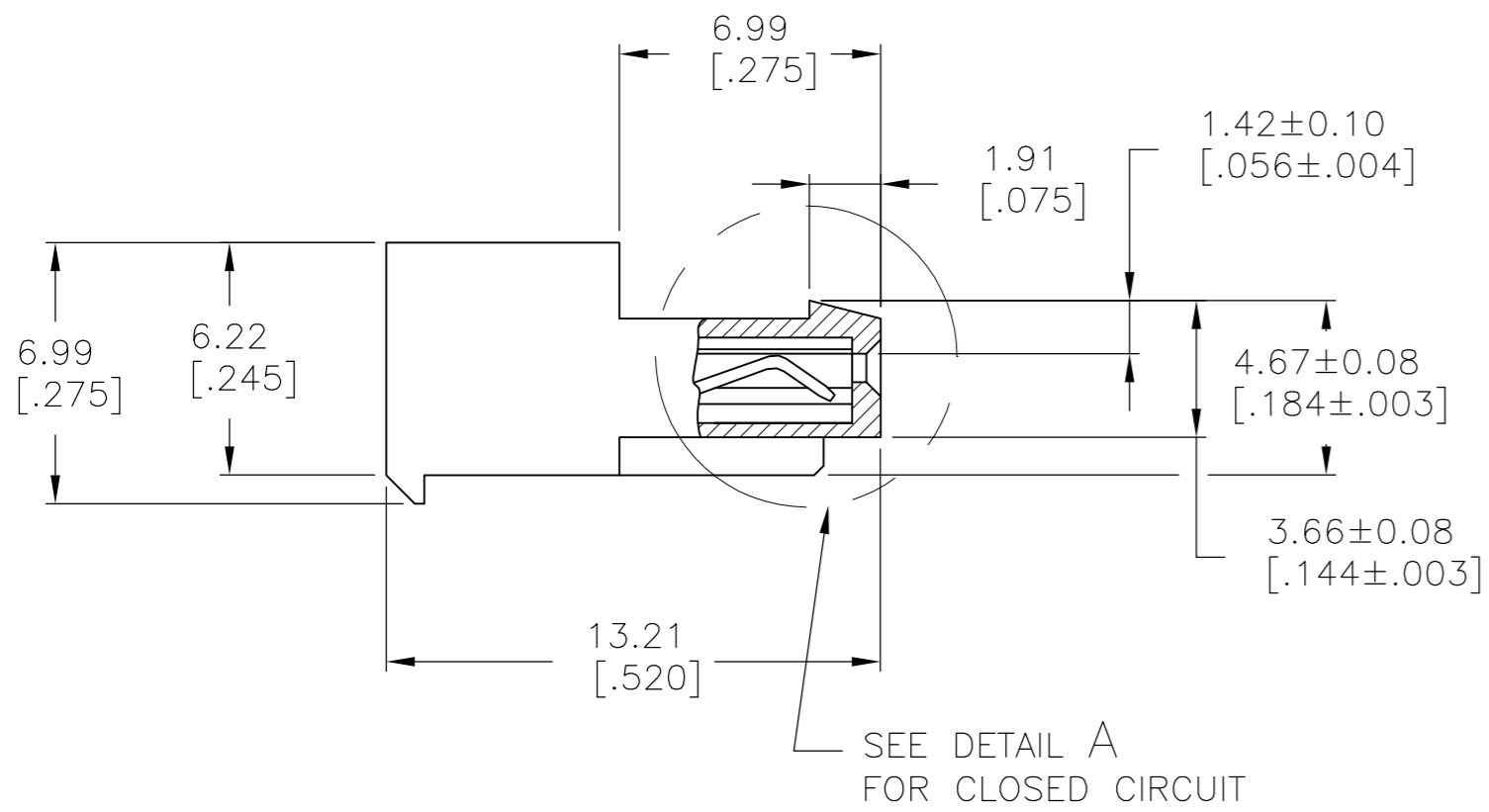
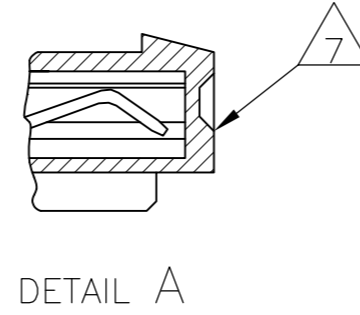
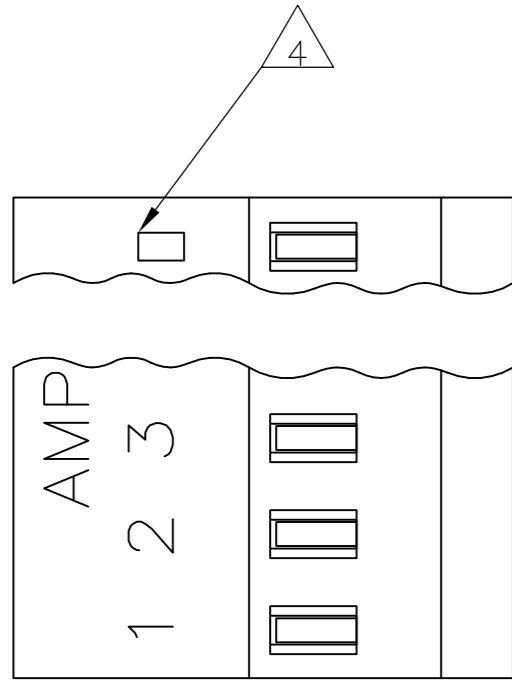

- 1 MATERIAL: CONNECTOR - NYLON UL94V-2 (WHITE).
CONTACTS - 0.30[.012] THICK COPPER ALLOY
MATTE WHISKER MITIGATED TIN
0.00203[.000080] MIN THICKNESS
OVER NICKEL UNDERPLATE OR BRIGHT
TIN-LEAD 93/7 0.00203[.000080] MIN
THICKNESS. SEE FINISH COLUMN FOR
PLATING TYPE.
- 2. CONTACTS ACCEPT 24 AWG WIRE WITH 1.52[.060] MAX
INSULATION DIAMETER.
- 3. CONTACTS MUST ACCEPT 0.64±.03[.025±.001] SQUARE
POST AND REMAIN LOCKED IN POSITION.
- 4 IDENTIFICATION NUMBER FOR LAST CIRCUIT MAY
NOT APPEAR ON ALL ASSEMBLIES.
- 5. DIMENSIONS IN BRACKETS ARE IN INCHES.
- 6. HOUSING FEATURES ARE: CLOSED END WITH LOCKING
RAMP.
- 7 DETAIL A SHOWS CIRCUIT NO.6 MOLDED CLOSED.

FINISH	DIM A	NO OF CIRCUITS	PART NO
TIN	22.86 [.900]	9	3-644031-9
OBSOLETE TIN-LEAD	22.86 [.900]	9	644031-9

METRIC

THIS DRAWING IS A CONTROLLED DOCUMENT.

DWN B. LEWIS 22 APR 91	 TE Connectivity MTA-100 CONNECTOR ASSEMBLY, 24 AWG, NO.6 CIRCUIT CLOSED, SPECIAL
CHK R. SWING 22 APR 91	
APVD G. MILLER 22 APR 91	
PRODUCT SPEC 108-1050	
APPLICATION SPEC 114-1019	SIZE A2
WEIGHT -	CAGE CODE 00779
CUSTOMER DRAWING	DRAWING NO C-644031
	RESTRICTED TO -
	SCALE 5:1
	SHEET 1 OF 1
	REV K1

单击下面可查看定价，库存，交付和生命周期等信息

[>>TE Connectivity\(泰科\)](#)