

THIS DRAWING IS UNPUBLISHED. RELEASED FOR PUBLICATION
 © COPYRIGHT - By - ALL RIGHTS RESERVED.

REVISIONS				
P	LTR	DESCRIPTION	DATE	APVD
E2		REVISED PER ECO-11-005027	11MAR11	RK HMR
E3		REVISED PER ECO-17-008114	30MAY2018	RS DR

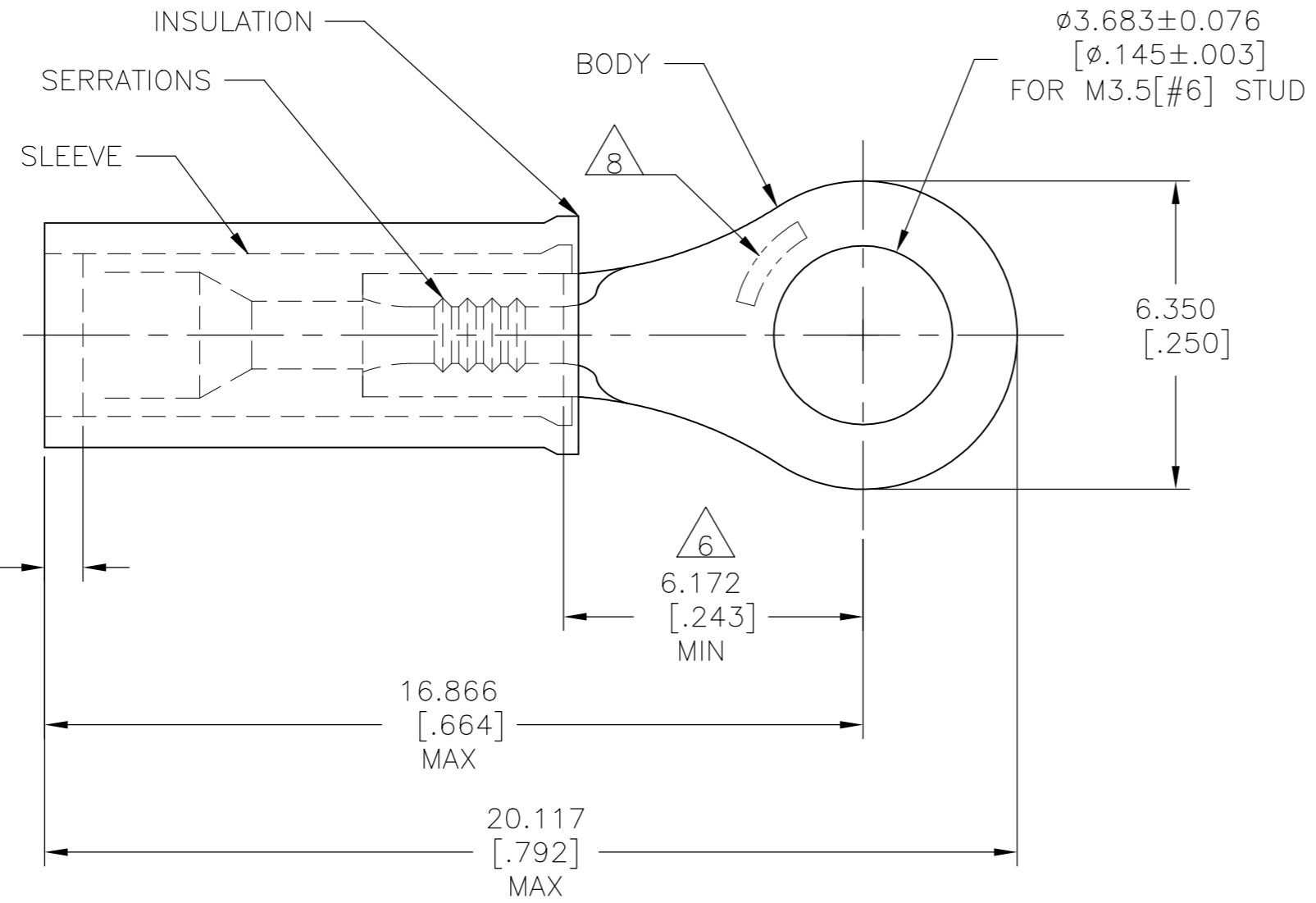
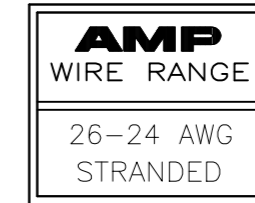

- 1 MUST BE CRIMPED WITH A 22-18 OR 22-16 PIDG (RED) TOOL
- 2 WIRE INSULATION DIA: 0.813-2.083 [.032-.082]
- 3 BODY MATERIAL THK: 0.686±0.051 [.027±.002]
- 4 FINISH:
 BODY & SLEEVE: TIN 0.0025400 [.000100]
 MIN EXT THK PER ASTM B545
 INSULATION: COLOR-YELLOW
- 5 MATERIAL:
 BODY & SLEEVE: CU PER ASTM B152
 INSULATION: NYLON PER ASTM D4066
- 6 APPLIES FROM EDGE OF METAL BBL TO THE CENTER OF STUD HOLE
- 7 MEETS MS25036-145, CLASS 1 & 2
- 8 STAMP AMP APPROX AS SHOWN

1000	LOOSE PIECE	53073
QTY	PACKAGE TYPE	PART NO.

CUSTOMER SERVICE SYSTEMS		MAX RECOMMENDED OPERATING TEMPERATURE: 150°C [221°F] MAX	THIS DRAWING IS A CONTROLLED DOCUMENT.		DWN JR RUTH 14JAN10	STE TE Connectivity Ltd.
FOR ADDITIONAL PRODUCT INFORMATION OR COPIES OF DRAWINGS AND TECHNICAL DOCUMENTS	PRODUCT INFORMATION CENTER 1-800-522-6752	VOLTAGE RATING: 300 V MAX	DIMENSIONS: mm [INCHES]	TOLERANCES UNLESS OTHERWISE SPECIFIED:	CHK T MICHIELUTTI 15JAN10	
FOR APPLICATION TOOLING INFORMATION	TOOLING ASSISTANCE CENTER 1-800-722-1111	CIRCULAR MIL AREA: 0.10-0.26mm² [202-509] STRANDED		0 PLC ± - 1 PLC ± - 2 PLC ± - 3 PLC ± 0.127 [.005] 4 PLC ± -	APVD T MICHIELUTTI 15JAN10	NAME TERMINAL, RING TONGUE, PIDG WIRE SIZE: 26-24 AWG
FOR ORDER ENTRY	1-800-526-5142	THIS DRAWING IS A CONTROLLED DOCUMENT FOR AMP INCORPORATED. IT IS SUBJECT TO CHANGE AND THE CONTROLLING ENGINEERING ORGANIZATION SHOULD BE CONTACTED FOR THE LATEST REVISION.	MATERIAL	FINISH	APPLICATION SPEC 114-2157	SIZE A3 CAGE CODE 00779 DRAWING NO C-53073 RESTRICTED TO -
			5	4	WEIGHT	CUSTOMER DRAWING SCALE 8:1 SHEET 1 OF 1 REV E3

单击下面可查看定价，库存，交付和生命周期等信息

[>>TE Connectivity\(泰科\)](#)