

## 1mm Rectangular Terminal

**NOTE**

All numerical values are in metric units [with U.S. customary units in brackets]. Dimensions are in millimeters. Unless otherwise specified, dimensions have a tolerance of  $\pm 0.13$  and angles have a tolerance of  $\pm 2^\circ$ . Figures and illustrations are for identification only and are not drawn to scale.

### 1. INTRODUCTION

This specification covers the requirements for application of 1mm rectangular terminals used in sealed and unsealed input/output (I/O) automotive connector systems such as powertrain and body control modules.

The terminal consists of a wire barrel, insulation barrel, and hood. The wire barrel contains serrations which help to retain the wire to the terminal after crimping. The insulation barrel helps to stabilize and support the wire. After insertion, the hood retains the terminal to the connector and protects the contacts. The terminals are supplied in reeled form for terminating with manual hand-held tools and automatic machines.

When corresponding with personnel, use the terminology provided in this specification to facilitate your inquiries for information. Basic terms and features of this product are provided in Figure 1.

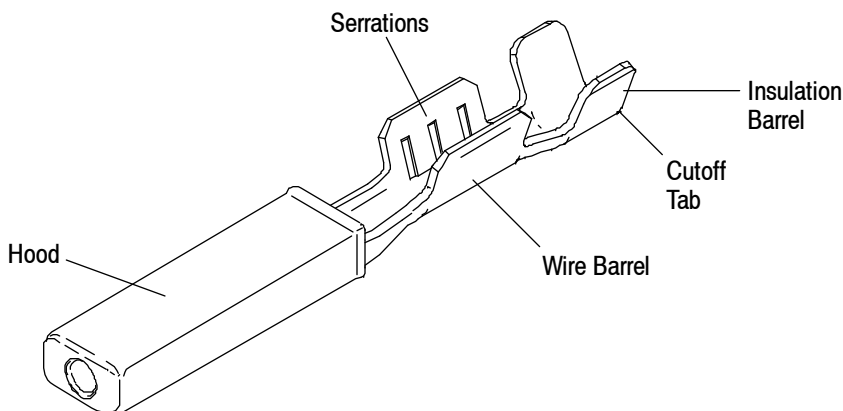

Figure 1

### 2. REFERENCE MATERIAL

#### 2.1. Revision Summary

Revisions to this application specification include:

- Changed company name and logo

#### 2.2. Customer Assistance

Reference Product Base Part Number 1456004 and Product Code H341 are representative of 1mm rectangular terminals. Use of these numbers will identify the product line and expedite your inquiries through a service network established to help you obtain product and tooling information. Such information can be obtained through a local Representative or, after purchase, by calling PRODUCT INFORMATION at the number at the bottom of page 1.

### 2.3. Drawings

Customer Drawings for product part numbers are available from the service network. If there is a conflict between the information contained in the Customer Drawings and this specification or with any other technical documentation supplied, call PRODUCT INFORMATION at the number at the bottom of this page.

### 2.4. Instructional Material

Instruction Sheets (408-series) provide assembly instructions and Customer Manuals (409-series) provide machine setup and operation procedures. Documents available which pertain to this product are:

- 408-8547 CERTI-CRIMP\* II Straight Action Hand Tools
- 408-9816 Handling of Reeled Products
- 409-5852 AMPOMATOR\* CLS III-G Lead-Making Machine
- 409-5878 AMPOMATOR CLS IV+ Lead-Making Machine

## 3. REQUIREMENTS

### 3.1. Safety

Do not stack product shipping containers so high that the containers buckle or deform.

### 3.2. Material

The terminals are available in a gold plated contact with a brass hood or a tin plated contact with a nickel plated hood.

### 3.3. Storage

#### A. Ultraviolet Light

Prolonged exposure to ultraviolet light may deteriorate the chemical composition used in the terminal material.

#### B. Shelf Life

The terminals should remain in the shipping containers until ready for use to prevent deformation. The terminals should be used on a first in, first out basis to avoid storage contamination that could adversely affect signal transmission and shield appearance degradation.

#### C. Chemical Exposure

Do not store terminals near any chemical listed below as they may cause stress corrosion cracking in the terminals.

Alkalies	Ammonia	Citrates	Phosphates	Citrates	Sulfur Compounds
Amines	Carbonates	Nitrites	Sulfur Nitrites		Tartrates

#### D. Reeled Terminals

Store coil wound reels horizontally and traverse wound reels vertically.

### 3.4. Wire Selection and Preparation

The terminals will accept stranded copper wire sizes 20 through 16 AWG with an insulation diameter range of 1.70 through 2.25. Proper strip length is necessary to properly insert the wire into the terminal. The strip length of the wire is shown in Figure 2.

**CAUTION** Reasonable care must be taken not to nick, scrape, or cut any strands during the stripping operation.

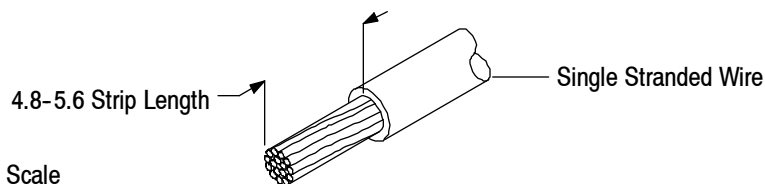

**Note:** Not to Scale

Figure 2

### 3.5. Crimp Requirements



*Wire insulation must not be cut or broken during the crimping operation. Reasonable care should be taken to provide undamaged wire terminations.*

The terminal must be crimped to the wire according to instructions packaged with applicable tooling.

#### A. Hood

The hood must be straight with no damage.

#### B. Cutoff Tab and Burr

Cutoff tabs are the remaining portion of the carrier strip after the terminal is cut from the strip. The following dimensional requirements will ensure proper application for these terminals.

1. The cutoff tab must not exceed the dimension shown in Figure 3.
2. The burr resulting from the cutoff tab shearing must not exceed the dimension shown in Figure 3.

#### C. Wire Barrel Crimp

The crimp applied to the wire barrel portion of the terminal is the most compressed area and is most critical in ensuring optimum electrical and mechanical performance of the crimped terminal. The wire insulation must not enter the wire barrel. The crimp height must be within the dimensions provided in Figure 3.

#### D. Effective Crimp Length

Effective crimp length is defined as that portion of the wire barrel, excluding bellmouths, fully formed by the crimping tool. For optimum crimp effectiveness, the crimp must be within the area shown and must meet the crimp requirements provided in Figure 3.

#### E. Wire Barrel Seam

The seam between the two sides of the wire barrel must be completely closed and there must be no evidence of loose wire strands or wire strands visible in the seam.

#### F. Wire Barrel Flash

Wire barrel flash is the formation that may appear on both sides of the wire barrel as the result of the crimping process. It must not exceed the dimension provided in Figure 3.

#### G. Insulation Barrel Crimp

The insulation barrel of the terminal must grip the wire insulation firmly without cutting into it. Care must be taken to prevent cutting, nicking, or scraping of the insulation.

#### H. Bellmouths

The front bellmouth and rear bellmouth shall be evident and conform to the dimensions given in Figure 3.

#### I. Wire Conductor and Insulation Location

After crimping, all conductors must be held firmly inside the wire barrel. No strands can be folded back over the wire insulation. The conductor ends must be flush with, or extend slightly beyond, the end of the wire barrel. The wire insulation must be inside the insulation barrel of the terminal, but must not enter the wire barrel. The wire conductors and insulation must both be visible in the transition area. See Figure 3.

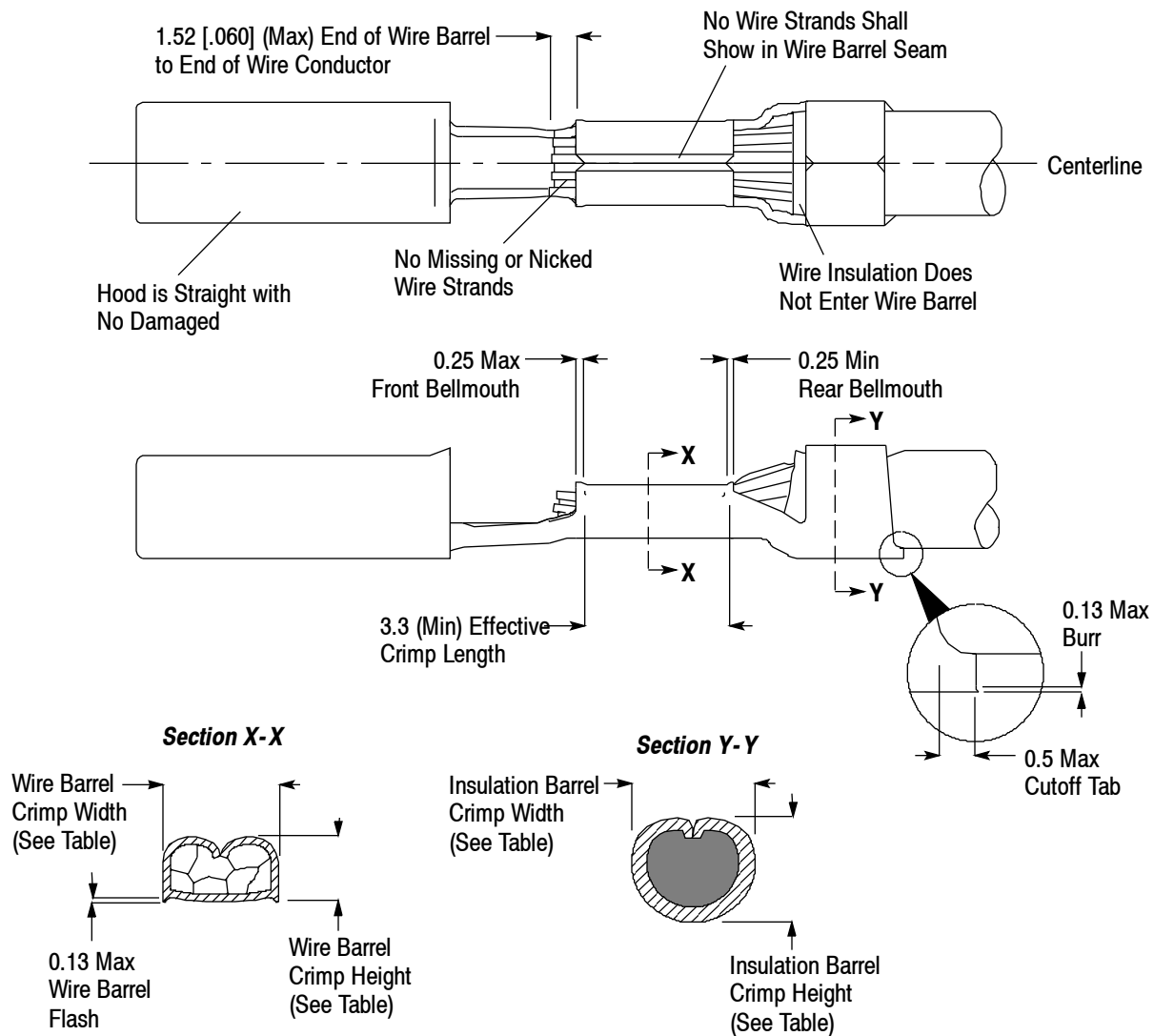

WIRE SIZE (AWG)	WIRE BARREL CRIMP • $\pm 0.05$		INSULATION BARREL CRIMP • $\pm 0.05$	
	HEIGHT	WIDTH	HEIGHT	WIDTH
20	1.05	1.60	1.95	2.00
18	1.15	2.05	2.10	2.75
16	1.32	2.05	2.15	2.75

● The developed crimp configurations result from using the specific tooling described in Section 5, TOOLING.

Figure 3

## J. Bend Allowance

The force applied during crimping may cause some bending between the wire barrel and wire. Such deformation is acceptable within the following limits. See Figure 4.

1. Side-to-Side

The crimped portion must not be bent from one side to the other beyond the limits shown.

2. Up and Down

The crimped portion must not be bent beyond the limits shown.

**Side-to-Side**

**Up and Down**

Figure 4

**K. Twist and Roll**

There should be no twist or roll of the wire barrel or mating portion of the crimped terminal that would cause overstress or impair usage. See Figure 5.

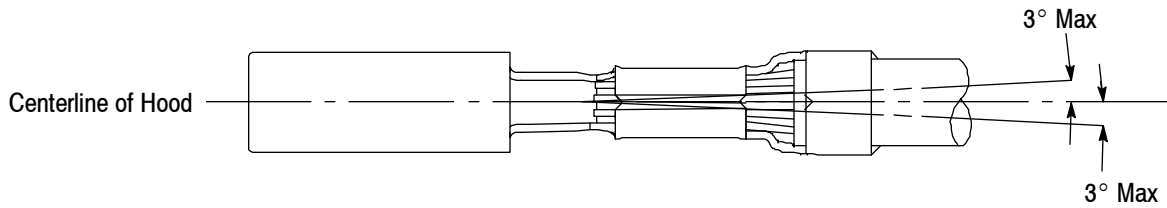
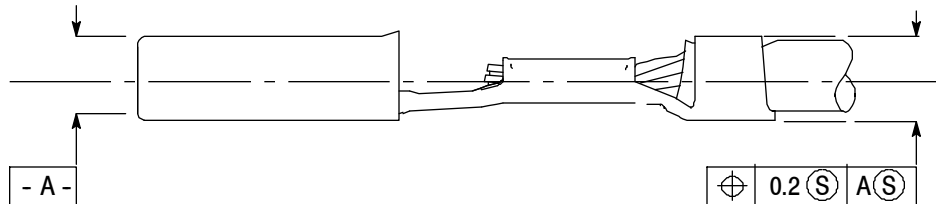
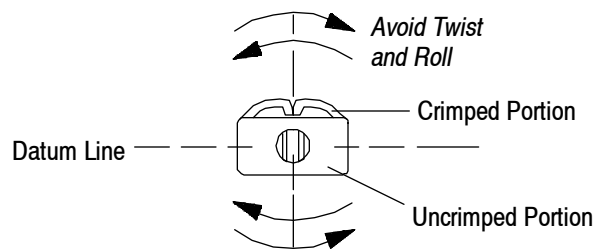

Figure 5

**3.6. Wire Bend Radii**

When inside the connector, the terminal must not be restricted in any way that may adversely affect the wire dress. It is recommended that wires be dressed to a bend radius of *at least* 10 times the outside diameter of the wire. Likewise, wire bundles should be dressed to a bend radius of *at least* 10 times the outside diameter of the bundle.



**CAUTION** DO NOT bend unsupported wire as this may cause strain on the terminals inside the connector.

**3.7. Repair**

Damaged or worn terminals may be replaced provided there is sufficient slack after restripping the wire; otherwise, the terminal must be discarded.

Terminals that do not meet crimp dimension requirements must be removed from wires, discarded, and replaced with new ones. When removing a terminal, cut the wire as close as possible to the end of the wire barrel.

**4. QUALIFICATION**

1mm rectangular terminals are not required to be qualified by Underwriters Laboratories Inc. (UL) or Canadian Standards Association (CSA).

## 5. TOOLING

Hand tools for manual application and automatic machines for power assisted application of reeled terminals are available to cover the full wire size range. Tooling part numbers and instructional material packaged with the tooling are shown in Figure 6.

### 5.1. Manual Tools

These hand tool assemblies consist of a hand tool frame with a die assembly. The tool has a ratchet to ensure full crimping pressure is applied to the terminal. The tool also has an insulation adjustment knob to regulate the crimp height of the terminal insulation barrel.

### 5.2. Automatic Machines

These power units provide the force required to drive the applicator (die assembly is included with this applicator) for crimping reeled terminals. They can be set up to automatically measure, cut, strip, and terminate wire. They provide for high volume, heavy duty production requirements. These machines are designed to be floor standing.

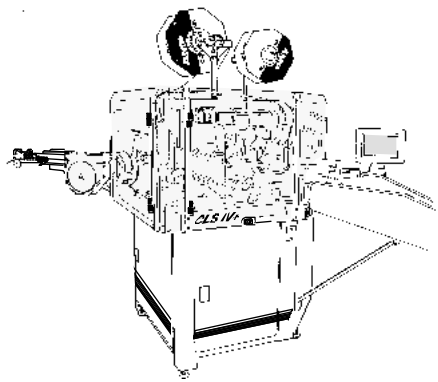

AMPOMATOR CLS IV+  
Lead-Making Machine  
356500-[ ] (409-5878)

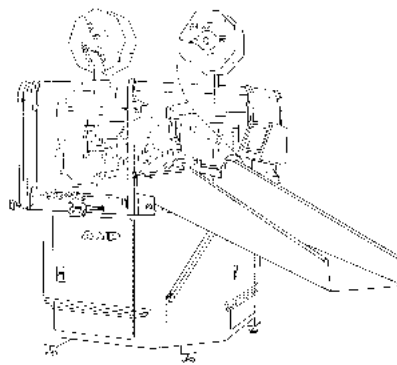

AMPOMATOR CLS III-G  
Lead-Making Machine  
122500-[ ] (409-5852)

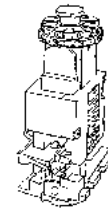

Heavy Duty Miniature  
Applicator 1385253-1  
(No Document)



CERTI-CRIMP II Straight Action  
Hand Tools (See Table) (408-8547)

WIRE SIZE (AWG)	HAND TOOL
20-18	91357-1
16	91356-1

Figure 6

**6. VISUAL AID**

The illustration below shows a typical application of 1mm rectangular terminals. This illustration should be used by production personnel to ensure a correctly applied product. Applications which DO NOT appear correct should be inspected using the information in the preceding pages of this specification and in the instructional material shipped with the product or tooling.

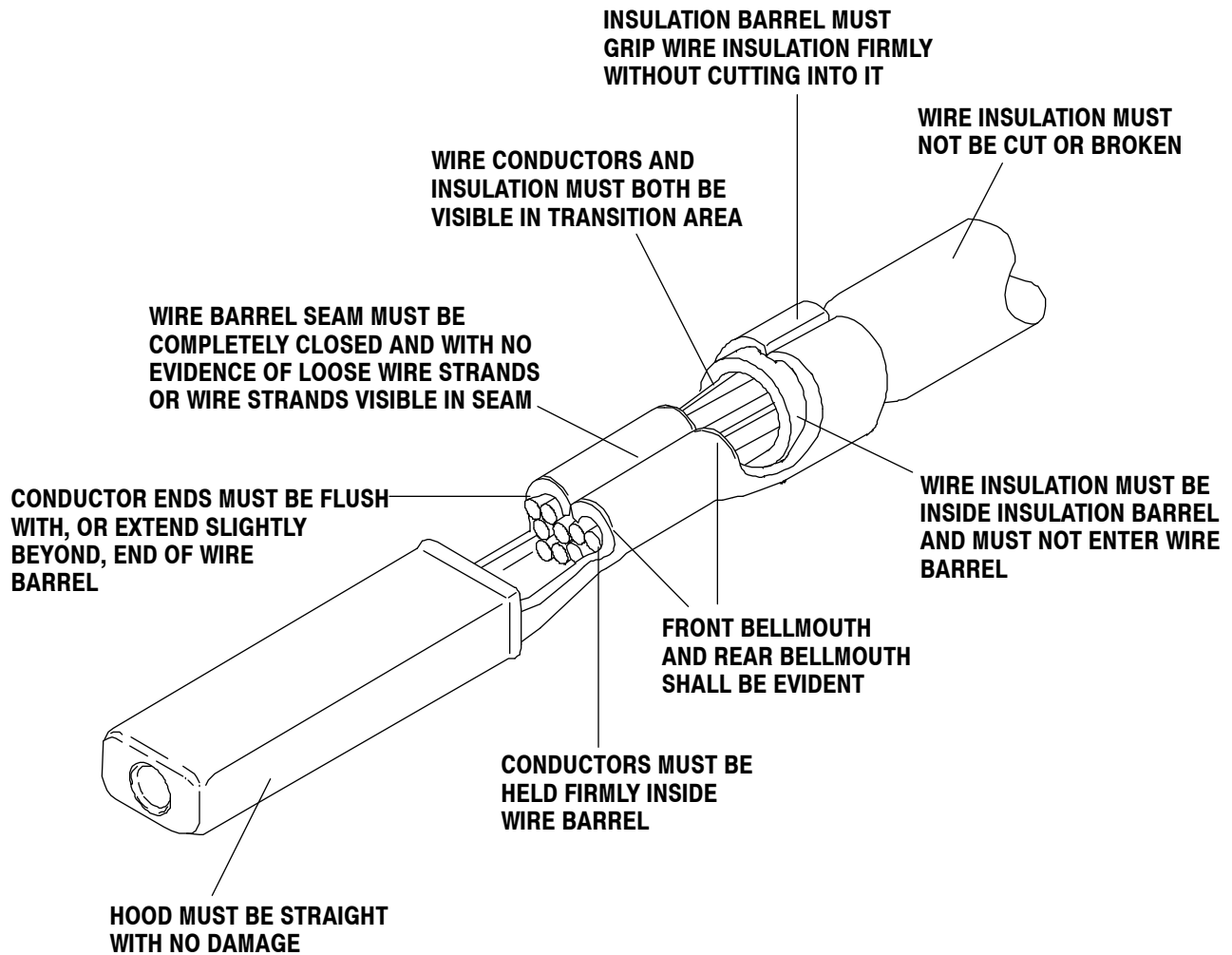

**FIGURE 7. VISUAL AID**

单击下面可查看定价，库存，交付和生命周期等信息

[>>TE Connectivity\(泰科\)](#)