

RECOMMENDED PC BOARD LAYOUT
1.57 [.062] PC BOARD THICKNESS

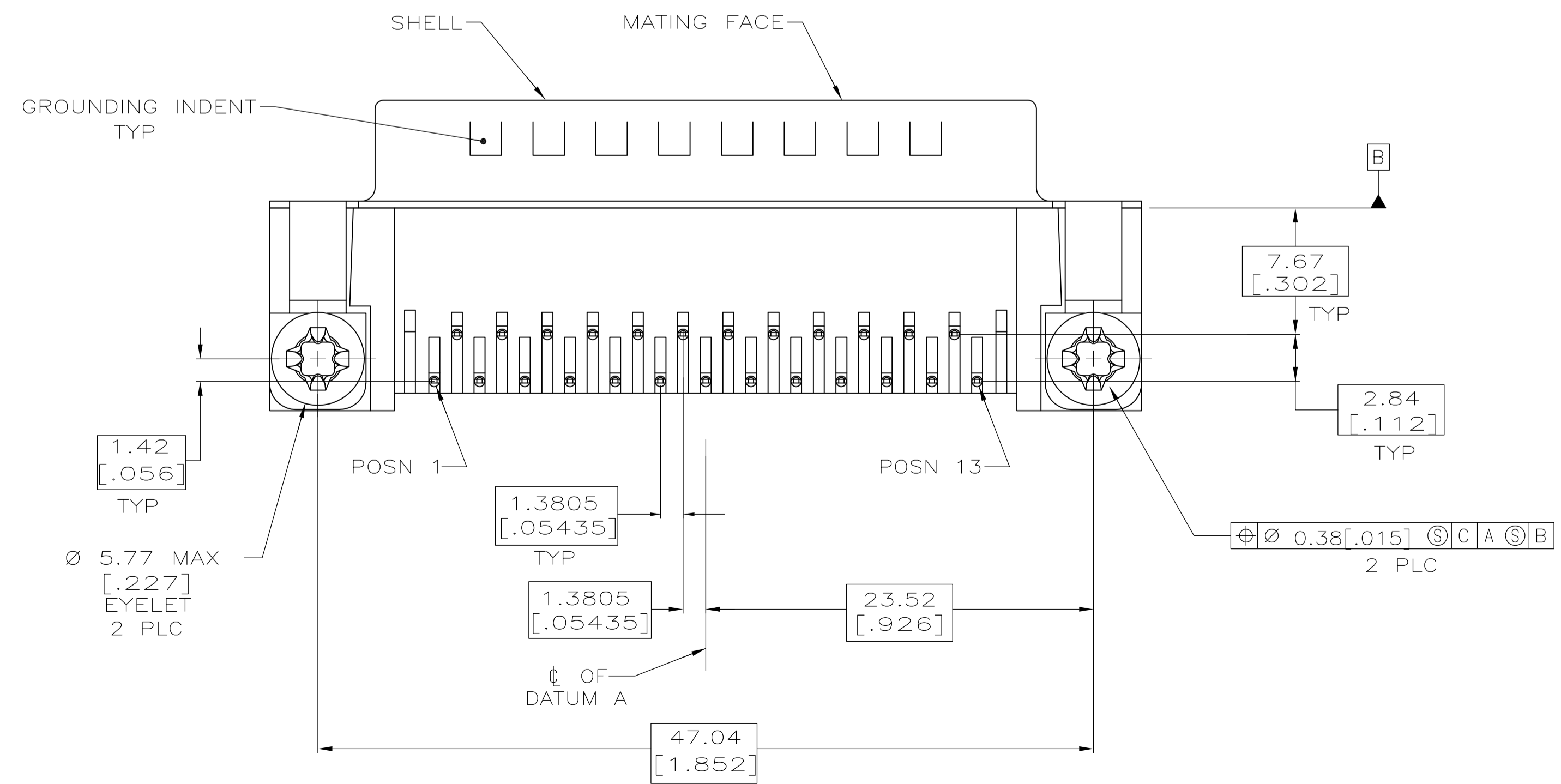

- 1 HOUSING: NYLON, THERMOPLASTIC, UL 94VO RATED, BLACK.
SHELL: CARBON STEEL,
PIN CONTACTS: BRASS.
EYELETS: BRASS.
THREADED INSERTS: ZINC.
BOARDLOCKS: COPPER ALLOY.
- 2 PIN CONTACTS: 0.76µm[.000030] MIN GOLD PLATE ON THE MATING SURFACES, 2.54µm[.000100] MIN TIN PLATE ON THE SOLDER END, 1.27µm[.000050] MIN NICKEL UNDERPLATE ON THE ENTIRE CONTACT
-OR-
GOLD FLASH OVER PALLADIUM-NICKEL PLATE, 0.76µm[.000030] MIN TOTAL ON THE MATING SURFACES, 2.54µm[.000100] MIN TIN PLATE ON THE SOLDER END, 1.27µm[.000050] MIN NICKEL UNDERPLATE ON THE ENTIRE CONTACT.
EYELETS: 2.54µm[.000100] MIN TIN OVER COPPER FLASH.
SHELL: 2.54µm[.000100] MIN TIN OVER 1.27µm[.000050] MIN COPPER.
THREADED INSERTS: CLEAR CHROMATE.
BOARDLOCKS: 3.81µm[.000150] MIN TIN OVER 1.27µm[.000050] MIN NICKEL.
- 3 PIN CONTACTS: GOLD FLASH ON THE MATING SURFACES, 2.54µm[.000100] MIN TIN PLATE ON THE SOLDER END, 1.27µm[.000050] MIN NICKEL UNDERPLATE ON THE ENTIRE CONTACT.
EYELETS: 2.54µm[.000100] MIN TIN OVER COPPER FLASH.
SHELL: 2.54µm[.000100] MIN TIN OVER 1.27µm[.000050] MIN COPPER.
THREADED INSERTS: CLEAR CHROMATE.
BOARDLOCKS: 3.81µm[.000150] MIN TIN OVER 1.27µm[.000050] MIN NICKEL.
- 4 DATUMS AND BASIC DIMENSIONS ESTABLISHED BY CUSTOMER.
- 5 POSITION TOLERANCE APPLIES AT CONTACT TIP.
- 6 BOARDLOCKS WILL ACCEPT .062 MAX PRINTED CIRCUIT BOARD THICKNESS.
7. COMPATIBLE WITH TYPICAL HIGH TEMPERATURE SOLDERING APPLICATIONS TO A MAXIMUM OF 225°C FOR A MAXIMUM DURATION OF 90 SECONDS. TEMPERATURE TO BE MEASURED ON CONNECTOR SURFACE.

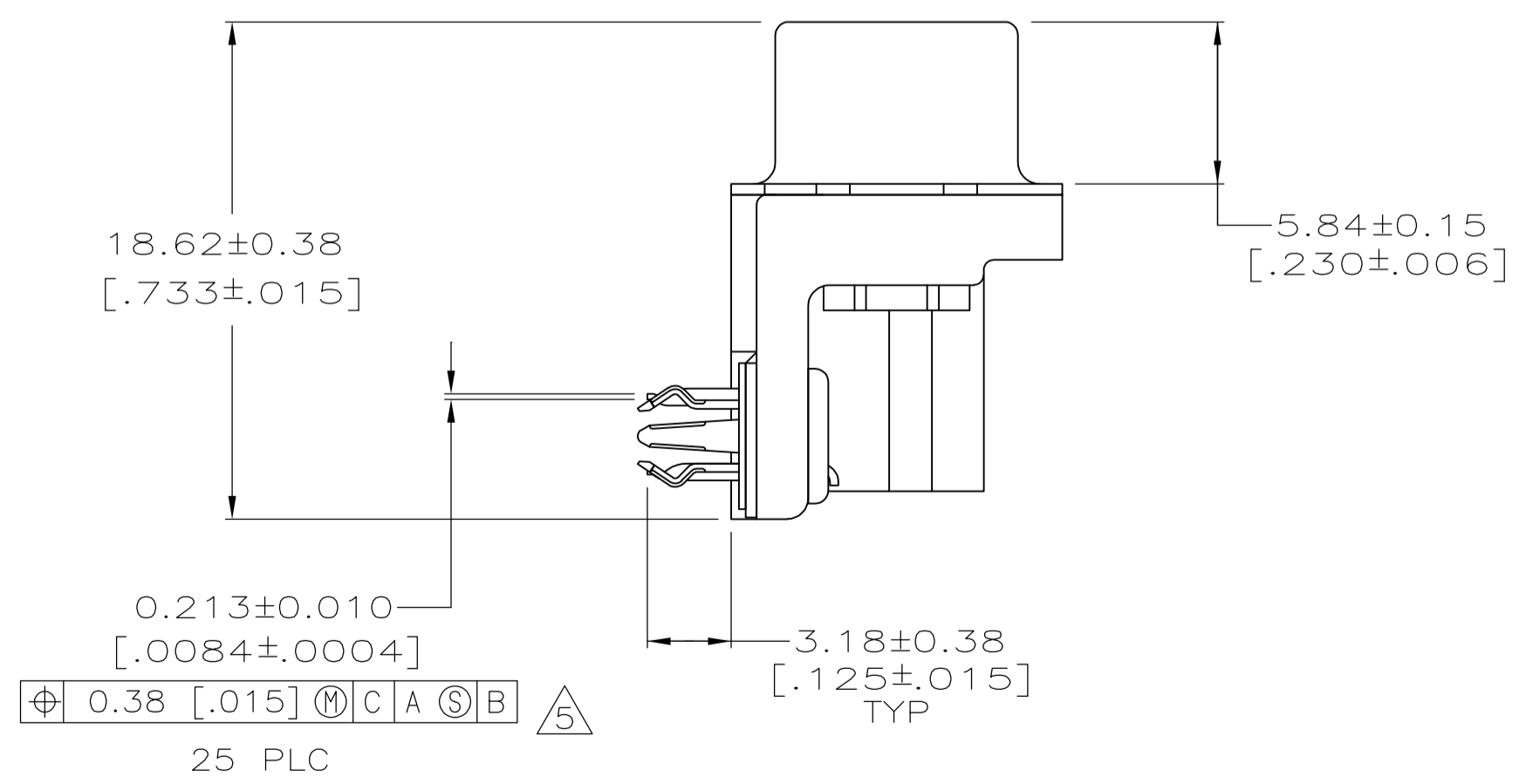

3	5788794-2
2	5788794-1
FINISH	PART NO

**COPYRIGHT 2005
TYCO ELECTRONICS CORP
ALL RIGHTS RESERVED**

THIS DRAWING IS A CONTROLLED DOCUMENT.

DIMENSIONS: mm [INCHES]	TOLERANCES UNLESS OTHERWISE SPECIFIED:	DIN J. ALCORTA - 04-07-05 DOCK5	APVD J. WALMSLEY 04-07-05	NAME
0 PLC ± -	1 PLC ± -	2 PLC ± 0.13 [.005]	3 PLC ± -	4 PLC ± -
MATERIAL		FINISH		SEE TABLE

PRODUCT SPEC	108-40025	APPLICATION SPEC	114-40010	SIZE	A1	CAGE CODE	00779	DRAWING NO	5788794	RESTRICTED TO
CUSTOMER DRAWING										

PLUG ASSEMBLY, SIZE 3, .318 SERIES, WITH FRONT METAL SHELL, HIGH TEMPERATURE, AMPLIMITE HD-20

TE Connectivity

SCALE 4:1 SHEET 1 OF 1 REV C

单击下面可查看定价，库存，交付和生命周期等信息

[>>TE Connectivity\(泰科\)](#)