

THIS DRAWING IS UNPUBLISHED. RELEASED FOR PUBLICATION
 © COPYRIGHT - BY TYCO ELECTRONICS CORPORATION. ALL RIGHTS RESERVED.

LOC	DIST	REVISIONS					
GP	00	P	LTR	DESCRIPTION	DATE	DWN	APVD
			A	RELEASED	31MAR06	RG	SF

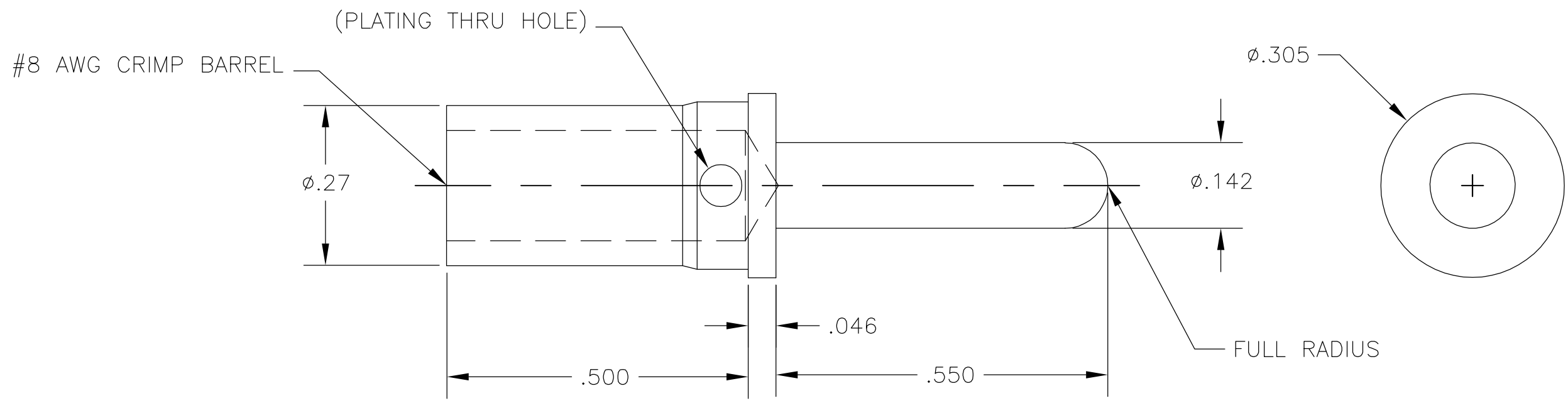

5. REFERENCE ELCON SERIES 701-11-02107
4. FINISH: SILVER PLATED .0002 MIN THK.
OVER NICKEL .00004 MIN THK.
3. MATERIAL: COPPER ALLOY
2. ITEMS PROVIDED TO THIS SPECIFICATION SHALL BE IDENTIFIED ON THE CONTAINER WITH THE FOLLOWING INFORMATION: PART NUMBER & DATE CODE OF MFR.
1. PART NUMBER CHANGES AND/OR DESIGN CHANGES AFFECTING ITEM INTERCHANGEABILITY REQUIRE PRIOR ELCON APPROVAL AND AUTHORIZATION BY REVISION TO THIS DRAWING.

1766192-1
PART NUMBER

THIS DRAWING IS A CONTROLLED DOCUMENT.		DWN R.GRZYBOWSKI	Tyco Electronics Corporation Harrisburg, PA 17105-3608														
DIMENSIONS: INCHES		CHK S.FLICKINGER	NAME														
TOLERANCES UNLESS OTHERWISE SPECIFIED:		APVD S.FLICKINGER	CONTACT, PIN, SIZE #8, CRIMP STANDARD, .43 PIN EXT.														
<table border="0"> <tr><td>0 PLC</td><td>± -</td></tr> <tr><td>1 PLC</td><td>± -</td></tr> <tr><td>2 PLC</td><td>± .02</td></tr> <tr><td>3 PLC</td><td>± .010</td></tr> <tr><td>4 PLC</td><td>± -</td></tr> <tr><td>ANGLES</td><td>± .5</td></tr> </table>		0 PLC	± -	1 PLC	± -	2 PLC	± .02	3 PLC	± .010	4 PLC	± -	ANGLES	± .5	PRODUCT SPEC	SIZE	CAGE CODE	DRAWING NO
0 PLC	± -																
1 PLC	± -																
2 PLC	± .02																
3 PLC	± .010																
4 PLC	± -																
ANGLES	± .5																
MATERIAL SEE NOTE 3		APPLICATION SPEC	A3	00779	C-1766192												
FINISH -		WEIGHT -	RESTRICTED TO -		SCALE 5:1												
CUSTOMER DRAWING			SHEET 1 OF 1	REV A													

单击下面可查看定价，库存，交付和生命周期等信息

[>>TE Connectivity\(泰科\)](#)