

## KILOVAC LEV200 Series Contactor With 1 Form X Contacts Rated 500+ Amps, 12-900Vdc

### Product Facts

- Designed to be the lowest cost sealed contactor in the industry with its current rating (500+A carry, 2000A interrupt at 320Vdc)
- Available with bottom or side mounting — not position sensitive
- Optional auxiliary contact for easy monitoring of power contact position
- Hermetically sealed — intrinsically safe, operates in explosive/harsh environments with no oxidation or contamination of coils or contacts, including long periods of non-operation
- Typical applications include battery switching and backup, DC voltage power control, circuit protection and safety
- Versatile coil/power connections
- Designed and built in accordance to AIAG QS9000
- RoHS compliant



Coil Data (Valid Over Temperature Range) <sup>4</sup>				
Nominal Voltage	12Vdc	24Vdc	48Vdc	72Vdc
Pickup Voltage (Will Operate)	9.0Vdc	19.0Vdc	38.0Vdc	57.0Vdc
Voltage (Max.)	15Vdc	30Vdc	60Vdc	90Vdc
Dropout Voltage	0.75 - 2.0Vdc	1.0 - 5.0Vdc	2.0 - 7.0Vdc	3.0 - 12.0Vdc
Coil Resistance @ 25° (Typ.)	11 ohms	40 ohms	145 ohms	357 ohms

### Ordering Information

Typical Part Number ►

**LEV200 A 4 N A A**

#### Series:

LEV200 = 500+ Amp, 12-900Vdc Contactor

#### Contact Form:

A = Normally Open

H = Normally Open with Aux. Contacts. (Option "H" requires option "A" in Coil Wire Length and option "N" in Coil Terminal Connector.)

Note: Other auxiliary contact forms available. Consult factory.

#### Coil Voltage:

4 = 12Vdc 5 = 24Vdc B = 28Vdc

6 = 48Vdc K = 72Vdc

8 = 96Vdc L = 110Vdc O = 115Vac 9 = 240Vac

Notes: Consult factory for detailed specifications and availability of coils not listed in "Coil Data" table above. In coil voltage codes, 115Vac is designated by the letter "O" rather than the numeral "0."

#### Coil Wire Length:

A = 15.3 in (390 mm) N = None (Requires option "A" in next step.)

#### Coil Terminal Connector:

N = None, stripped wires

(Requires option "A" in previous step.)

A = Studs, #10-32 Threaded (Electrical connection is made to the tab at the base of the stud.)

Note: Specify option A, stripped wires, for coil voltages > 96Vdc

#### Mounting & Power Terminals:

A = Bottom Mount & Male 10mm x M8 Threaded Terminals

F = Side Mount & Male 10mm x M8 Threaded Terminals

Consult factory regarding other available mountings and power terminals.

### Performance Data

#### Contact Arrangement, Power

Contacts — 1 Form X (SPST-NO-DM)

#### Rated Operating Voltage —

12 - 900 VDC

#### Continuous (Carry) Current,

Typical — 500 A @ 65°C, 400 mcm conductors

Consult TE for required conductors for higher (500+ A) currents

#### Make/Break Current at Various Voltages <sup>1</sup> — See graph next page

Break Current at 320VDC <sup>1</sup> — 2,000 A, 1 cycle <sup>3</sup>

#### Contact Resistance, Typ.

(@200A) — 0.2 mohms

#### Load Life — See graph next page

Mechanical Life — 1 million cycles

#### Contact Arrangement, Auxiliary

Contacts — 1 Form A (SPST-NO)

#### Aux. Contact Current, Max. —

2A @ 30VDC / 3A @ 125VAC

#### Aux. Contact Current, Min. —

100mA @ 8V

#### Aux. Contact Resistance, Max. —

0.417 ohms @ 30VDC /

.150 ohms @ 125VAC

#### Operate Time @ 25°C —

Close (includes bounce), Typ. — 25 ms

Bounce (after close only), Max. — 7 ms

Release (includes arcing), Max @ 2000A — 12 ms

#### Dielectric Withstanding Voltage —

2,200 Vrms @ sea level (leakage <1mA)

#### Insulation Resistance @ 500VDC —

100 megohms <sup>2</sup>

#### Shock, 11ms 1/2 Sine, Peak,

Operating — 20 G

#### Vibration, Sine, 80-2000Hz.,

Peak — 20 G

#### Operating Ambient Temperature —

-40°C to +85°C

#### Weight, Typical — 1.3 lb. (.60 kg)

#### Notes:

<sup>1</sup> Main power contacts

<sup>2</sup> 50 at end of life

<sup>3</sup> Does not meet dielectric & IR after test, 1700 amp for unit with Aux. Contacts

<sup>4</sup> Contacts will operate with  $0.8V_{nom} < V_{coil} < 1.1V_{nom}$  over temperature range.

#### Invalid

#### Combinations/Reason

LEV200H-NA\_ No auxiliary function with coil studs

LEV200\_ONA\_

No coil studs with rectifier circuit

LEV200\_9NA\_

No coil studs with rectifier circuit

LEV200\_O\_F

No side mount with rectifier circuit

LEV200\_9\_F

No side mount with rectifier circuit

For factory-direct application assistance, dial 800-253-4560, ext. 2055, or 805-220-2055.

**KILOVAC LEV200 Series** (Continued)

**Outline Dimensions**

**Side Mount Enclosure**

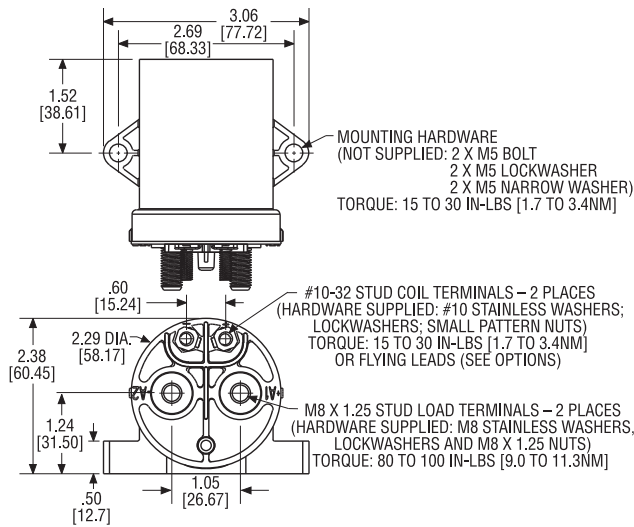

**Note:** When stud terminals are specified for coil connections, the electrical connection is made at the tab located at the base of the stud.

**Bottom Mount Enclosure**

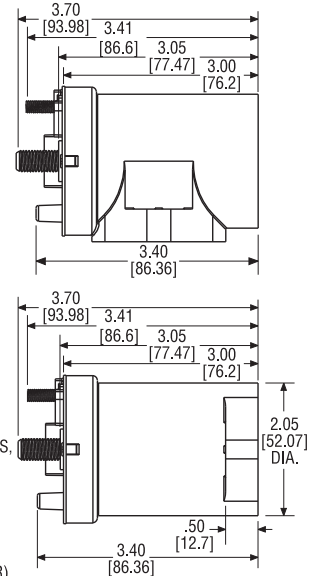
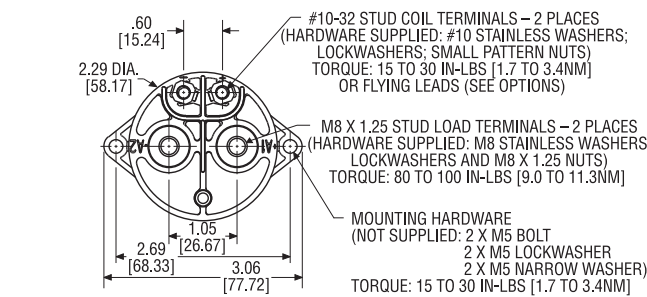

**Estimated Make & Break Power Switching Ratings**

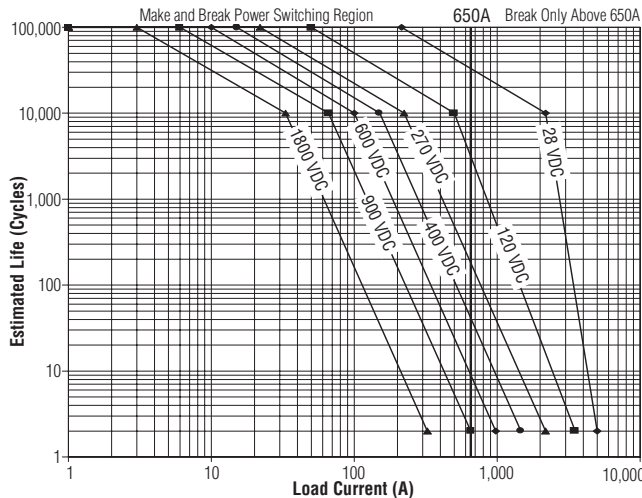

**NOTES:**

- 1) For resistive loads with 300µH maximum inductance. Consult factory for inductive loads.
- 2) Estimates based on extrapolated data. User is encouraged to confirm performance in application.
- 3) End of life when dielectric strength between terminals falls below 50 megohms @ 500VDC.
- 4) The maximum make current is 650A to avoid contact welding.

**LEV200 Capacitive Make Test Curves for Pre-Charged Motor Controller**

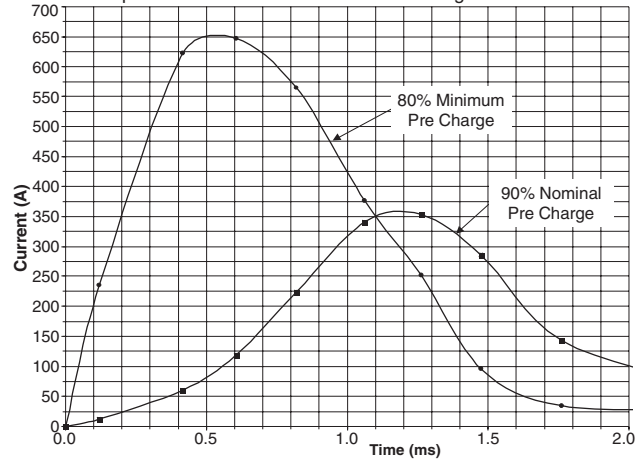

For factory-direct application assistance,  
 dial 800-253-4560, ext. 2055, or  
 805-220-2055.

单击下面可查看定价，库存，交付和生命周期等信息

[>>TE Connectivity\(泰科\)](#)