

THIS DRAWING IS UNPUBLISHED. RELEASED FOR PUBLICATION  
 © COPYRIGHT - By - ALL RIGHTS RESERVED.

REVISIONS				
P	LTR	DESCRIPTION	DATE	APVD
H5		OBSOLETE PRELIMINARY PN 63459-5	23OCT2018	SV   PKS

- FOR MAG-MATE CAVITY SPECIFICATION REFER TO APPLICATION SPEC #114-2066.
- CONTINUOUS STRIP ON REELS WITH TERMINALS LOCATED ON .330 CENTERS.
- AFTER INSERTION INTO PLASTIC HOLDER TAB PORTION MUST BE BENT OVER 45° TO 90° OR MAG-MATE MUST BE POTTED-IN TO PREVENT PULL-OUT WHEN MATING RECEPTACLE IS DISCONNECTED.
- FOR COPPER OR ALUMINUM WIRE. 2 WIRES MAX OF THE SAME SIZE AND TYPE PER SLOT
- VARNISH RESIST OVER TIN PER ASTM-B545.

IDENTIFICATION NUMBER FOR MAGNET WIRE RANGE

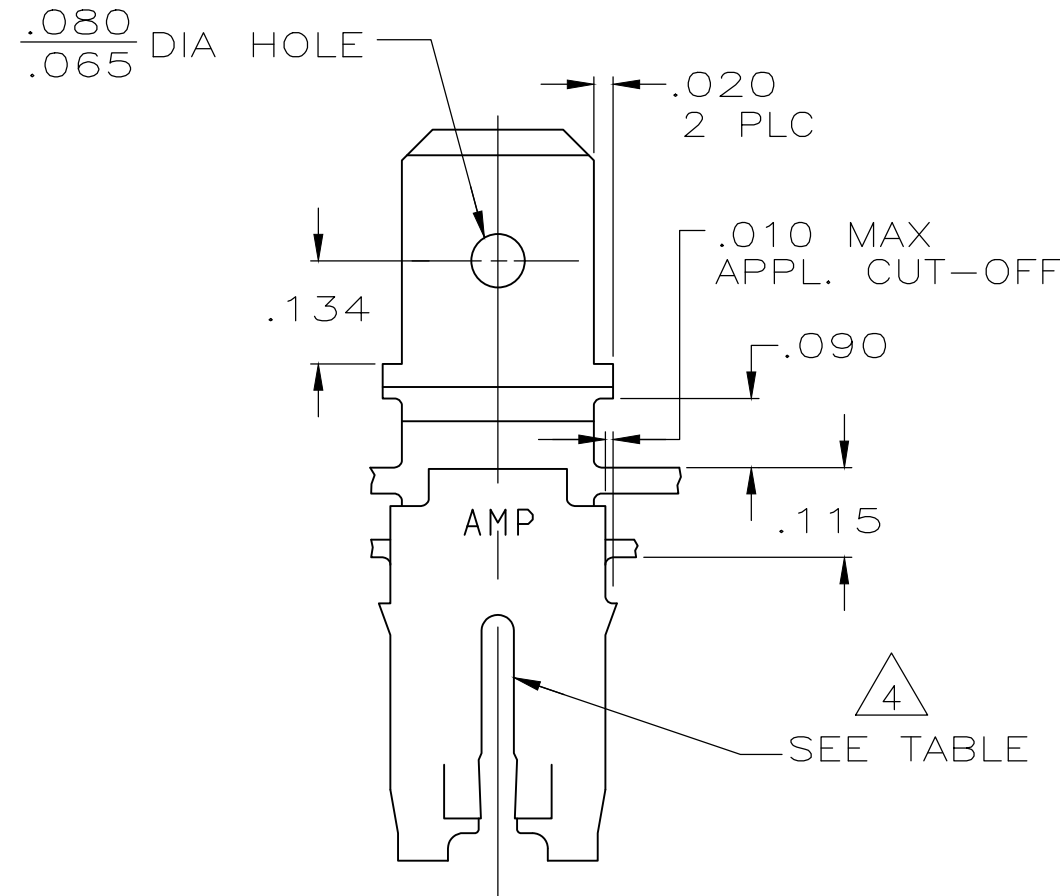
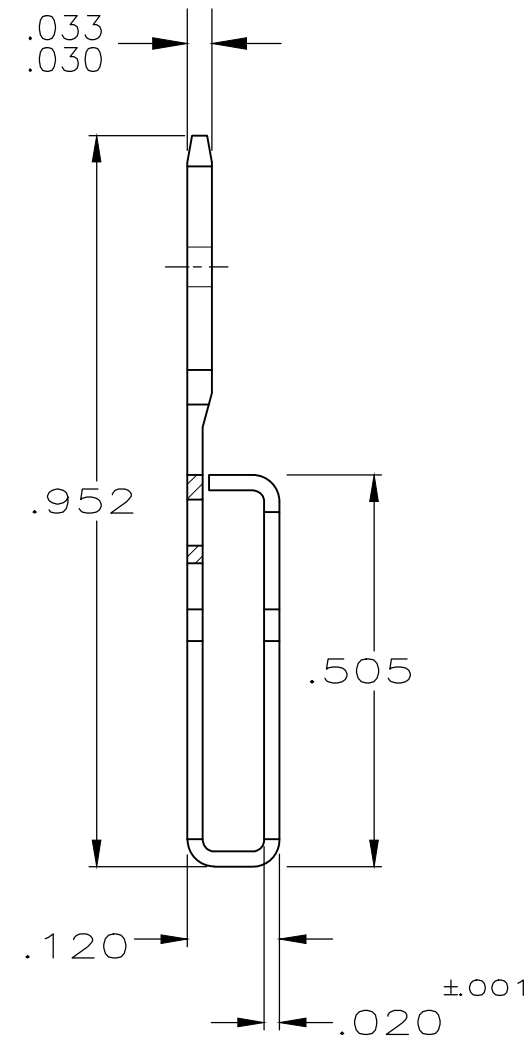
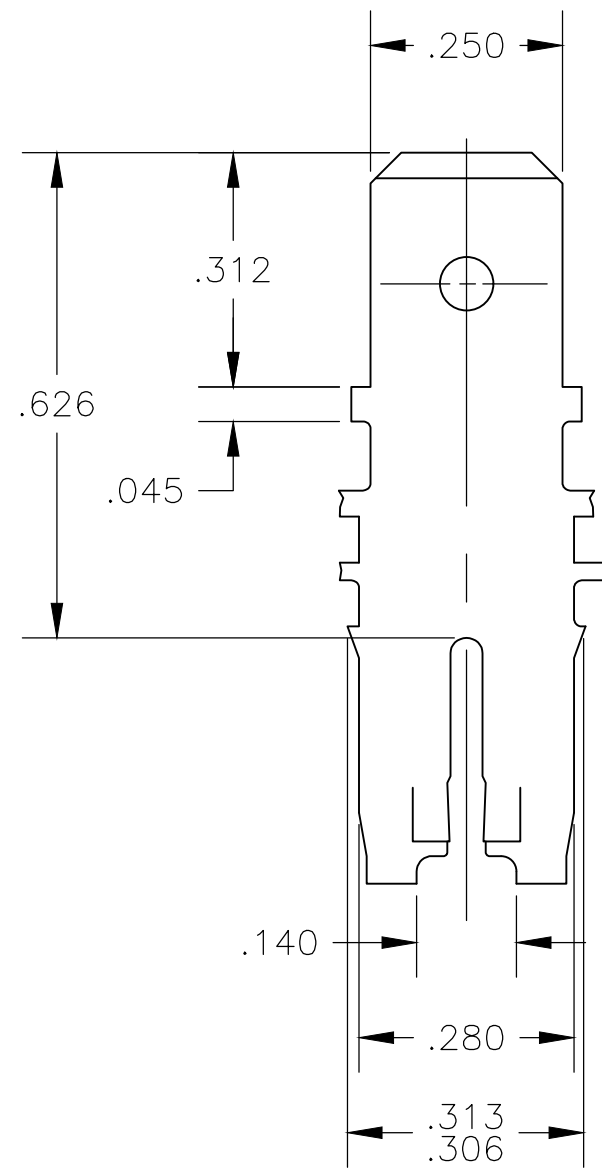
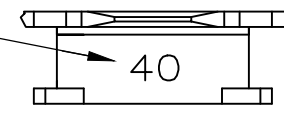

OBSOLETE	N/A	#15-#16	UNPLATED	63459-5
OBSOLETE	#14-#15	#15-#16	SPECIAL	63459-4
	#14-#15	#15-#16	STANDARD	63459-3
	#14-#15	#15-#16	TIN	63459-2
OBSOLETE		#15-#16	VARNISH RESIST OVER TIN	63459-1
	ALUMINUM	COPPER	FINISH	PART NO
	MAGNET WIRE RANGE			

THIS DRAWING IS A CONTROLLED DOCUMENT.		DWN	JR RUTH	1/26/87	 TE Connectivity
DIMENSIONS: INCHES		CHK	G YETTER	1/29/87	
TOLERANCES UNLESS OTHERWISE SPECIFIED:		APVD	J SWARTZ	1/29/87	
0 PLC ± - 1 PLC ± - 2 PLC ± - 3 PLC ± .015 4 PLC ± - ANGLES ± -		PRODUCT SPEC	NAME		
MATERIAL	BRASS	FINISH	SEE TABLE	WEIGHT	0
		SCALE	4:1	SHEET	1 OF 1
		CUSTOMER DRAWING	SIZE	A2	CAGE CODE
			DRAWING NO	C-63459	RESTRICTED TO
			REVISION	H5	

单击下面可查看定价，库存，交付和生命周期等信息

[>>TE Connectivity\(泰科\)](#)