

LOC		DIST		REVISIONS			
P	LTR	DESCRIPTION	DATE	DNW	APVD		
T		REV PER ECO-15-016062	09NOV15	KG	CD		

1. THIS RCPT. IS DESIGNED TO CONFORM TO THE LATEST ISSUE OF MIL-C-24308.
2. MAX WIRE INSUL TO BE USED WITH THIS RCPT. IS $\phi.054$.
3. METAL RETENTION CLIPS ARE INCLUDED IN INSERTS.
4. PACKAGE STAMPED M 24308/2-287F.
5. THIS RCPT. WILL ACCEPT SIZE 22 SOCKET CONTACT M 39029/57-354 OR ANY TYCO HDD-22 SOCKET CONTACT.
6. MFG'S PART NO. STAMPED ON CONNECTOR REPRESENTS KIT NUMBER WITH CONTACTS.
7. UL/CSA DESIGNATION STAMPED ON SHELL.
8. 204514 INK STAMPED, NEAR SIDE. M24308/2-12F INK STAMPED, FAR SIDE.
9. 204502-4 INK STAMPED, NEAR SIDE.
10. FINISH: BRIGHT TIN PER ASTM-B-545, .000400-.000550 THK OVER COPPER PER AMS2418, .000050 MIN THK.

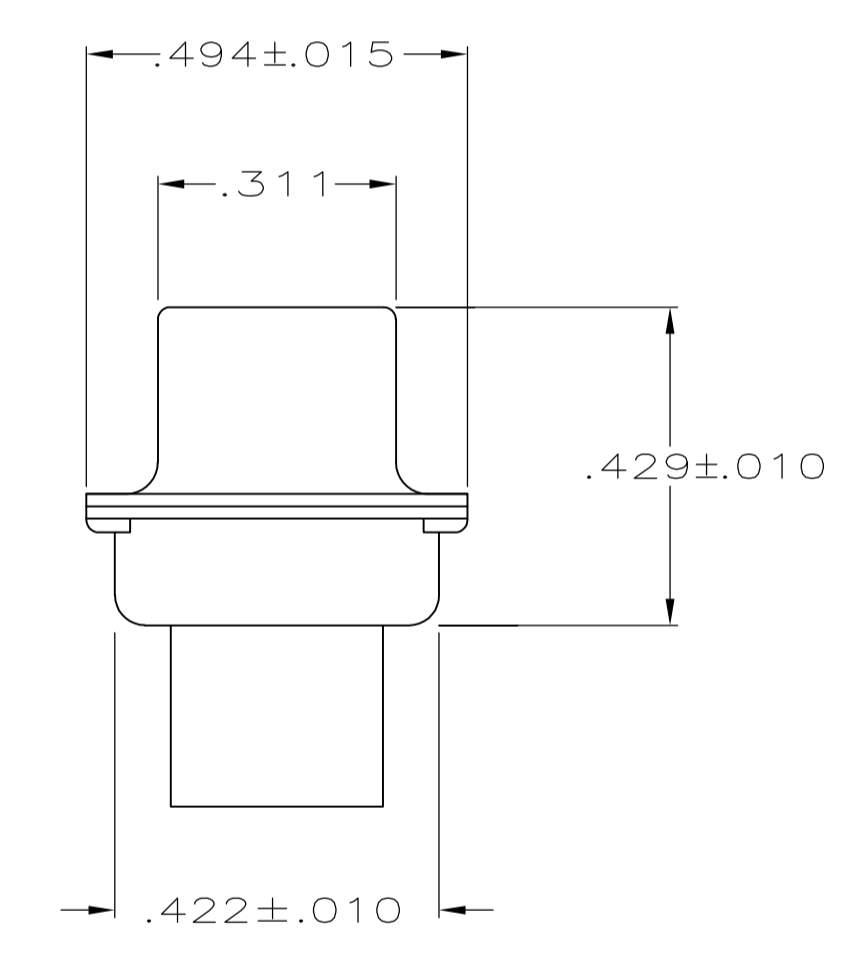
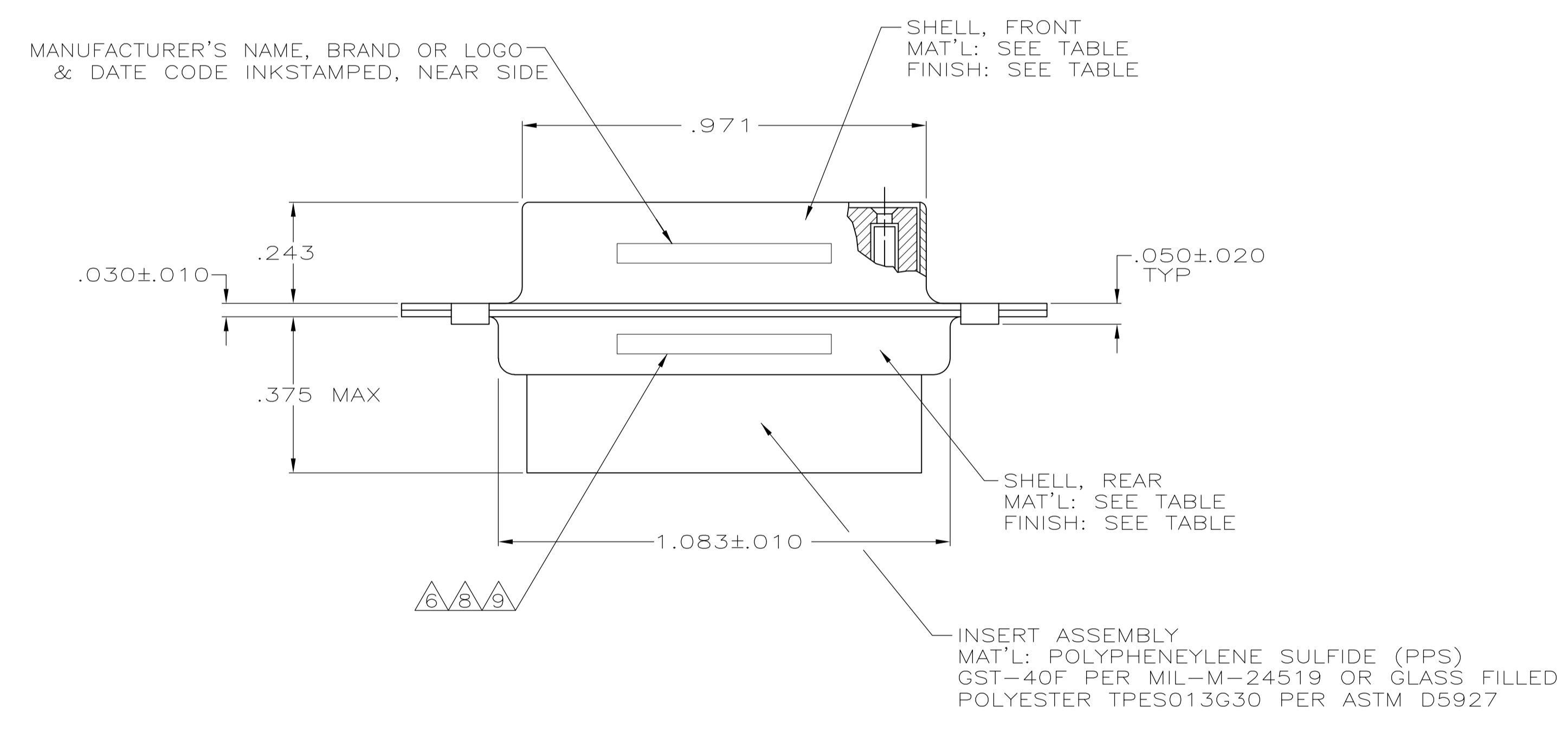
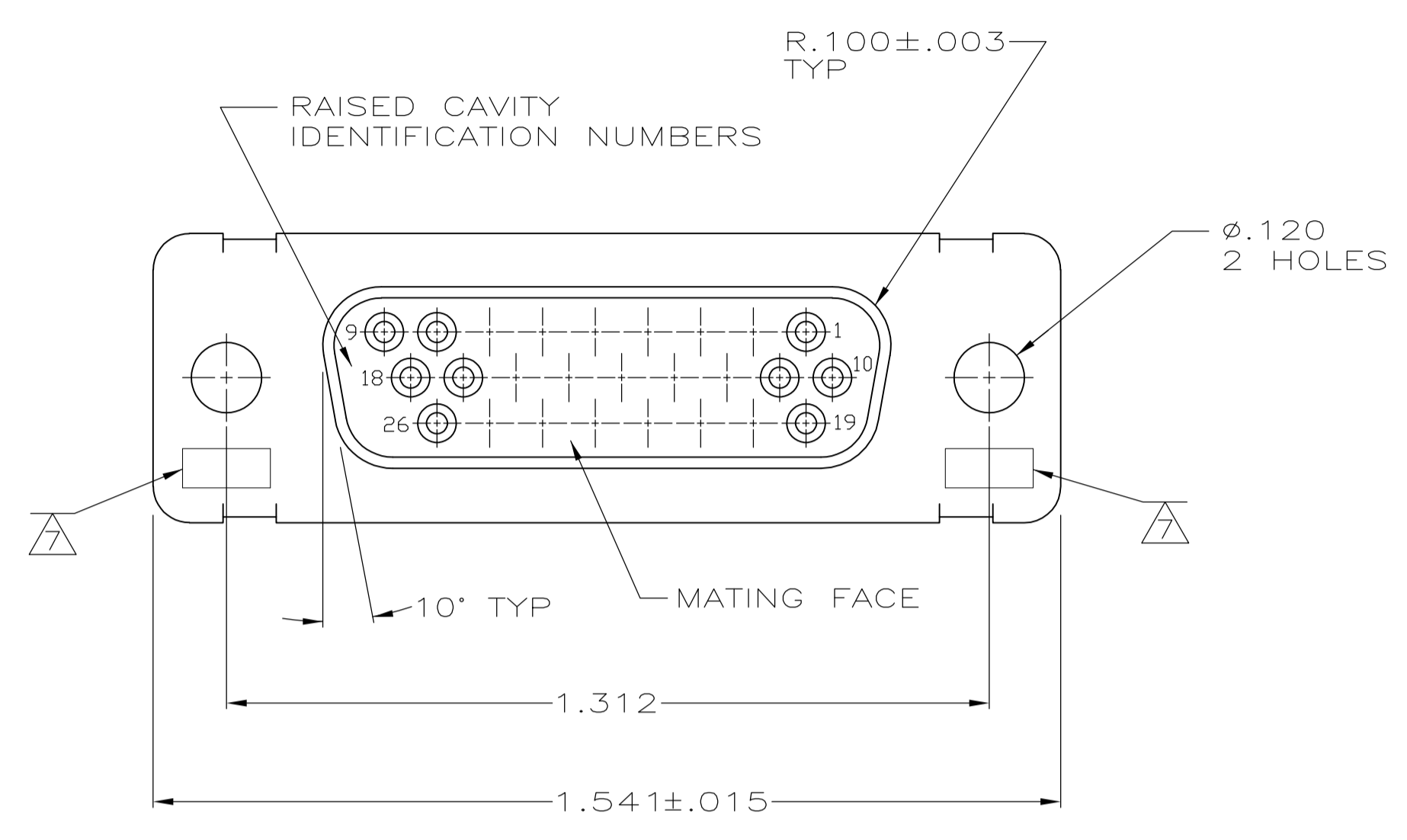

REMARKS	FINISH	SHELL MATERIAL	PART NO.
SUPSD BY 204502-1	-	CADMIUM PER QQ-P-416	STEEL, CLASS G 204502-4
SUPSD BY 206501-4	-	CADMIUM PER QQ-P-416	STEEL, CLASS G 204502-3
	-	CADMIUM PER QQ-P-416	BRASS 204502-2
	-	CADMIUM PER QQ-P-416	STEEL, CLASS G 204502-1

THIS DRAWING IS A CONTROLLED DOCUMENT.

DIMENSIONS: INCHES	TOLERANCES UNLESS OTHERWISE SPECIFIED:	0 PLC ± -	1 PLC ± -	2 PLC ± -	3 PLC ± .005	4 PLC ± -	ANGLES ± 0°30'
--------------------	--	-----------	-----------	-----------	--------------	-----------	----------------

MATERIAL: SEE TABLE FINISH: SEE TABLE WEIGHT: -

CUSTOMER DRAWING SCALE: 4:1 SHEET 1 OF 1 REV T

APPROVED: F.C. BALLEW DATE: 25-JAN-88

NAME: AMPLIMITE RCPT. FOR SOCKET CONTACTS HI-DENSITY D CONNECTOR SIZE 2 (26 POSN) SERIES 90

SIZE: A1 CASE CODE: 00779 DRAWING NO: 204502

RESTRICTED TO: -

单击下面可查看定价，库存，交付和生命周期等信息

[>>TE Connectivity\(泰科\)](#)