

THIS DRAWING IS UNPUBLISHED. RELEASED FOR PUBLICATION  
 © COPYRIGHT - By - ALL RIGHTS RESERVED.

SUGGESTED MATING TAB.  
 SCALE 8:1

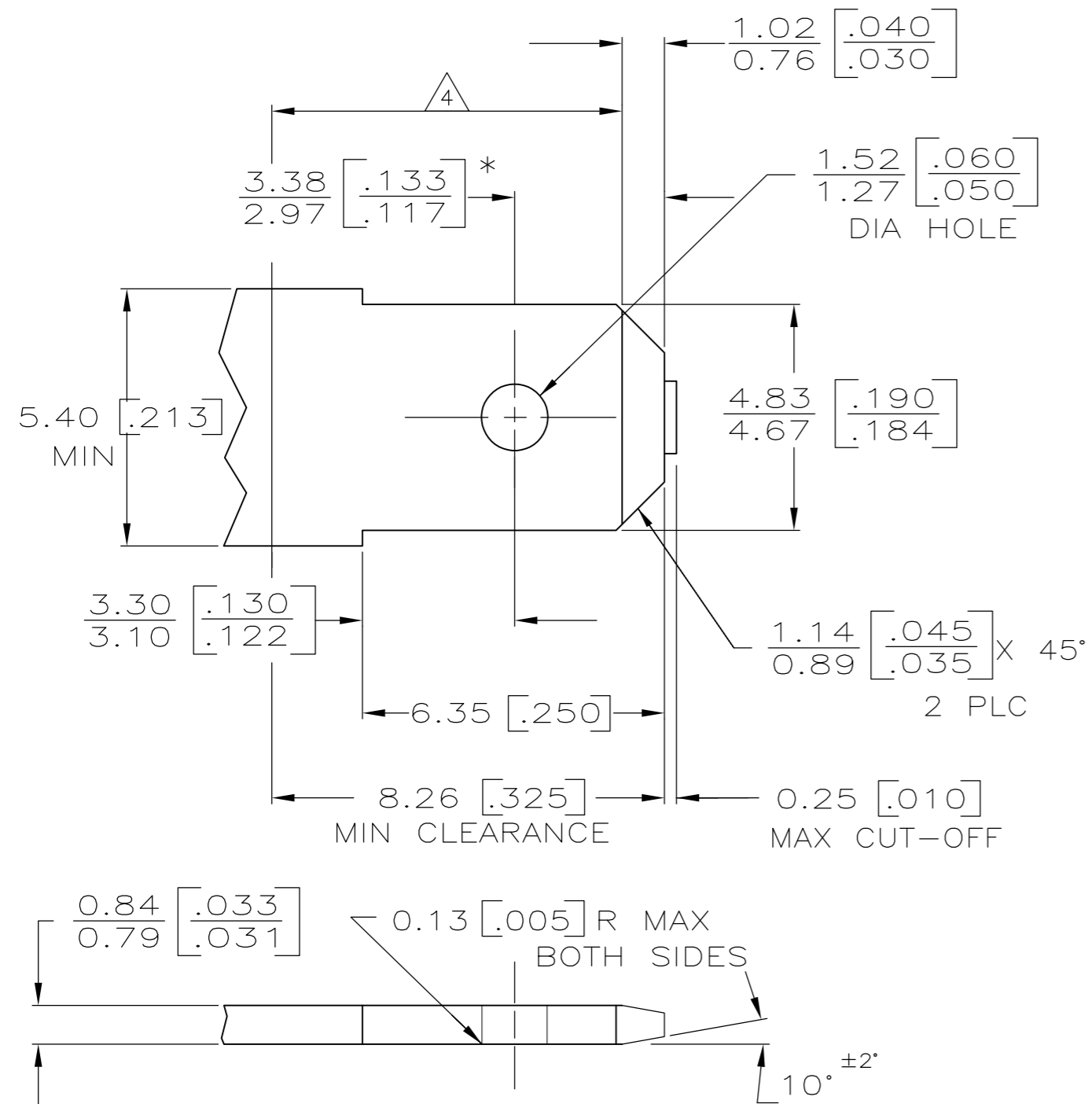

- 1 MATL: #2 HARD BRASS OR NICKEL PLATE STEEL.
  - 2 NO BURRS PERMISSIBLE AT HOLE.
  - 3 TIN PLATING IS REQUIRED ON BRASS WHEN TERMINAL TEMPERATURE IS OVER 225° F.
  - 4 MUST BE FLAT WITHIN 0.076[.003] OVER THIS LENGTH.
  - 5 HOLE MUST BE SYMMETRICAL ABOUT TAB  $\epsilon$  WITHIN 0.076[.003].
- \* TO BE USED ONLY WHEN SHOULDER IS ELIMINATED.

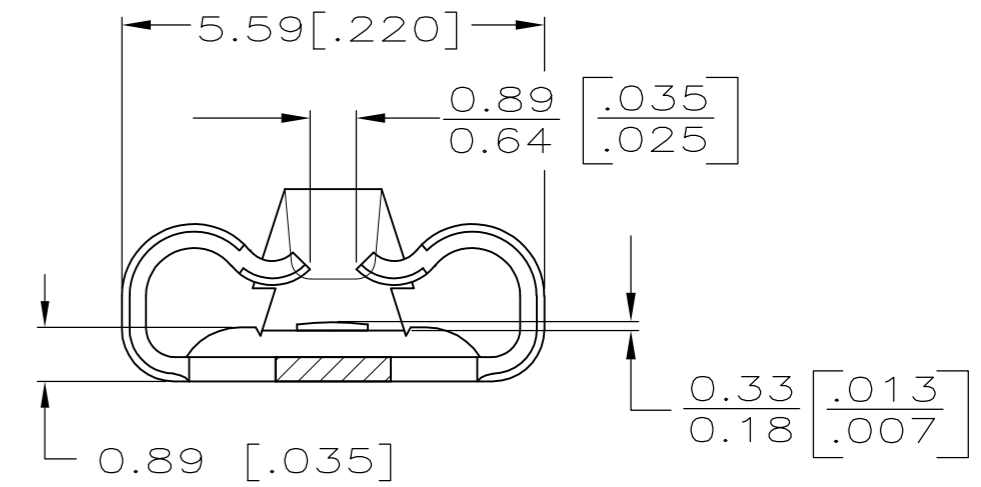
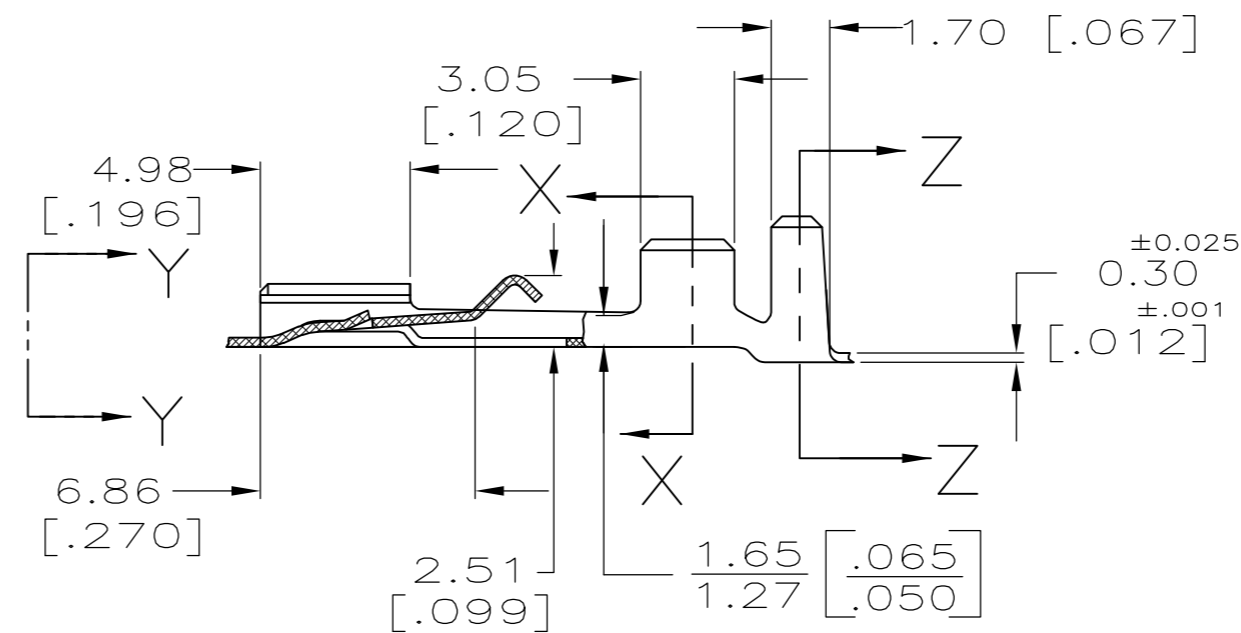
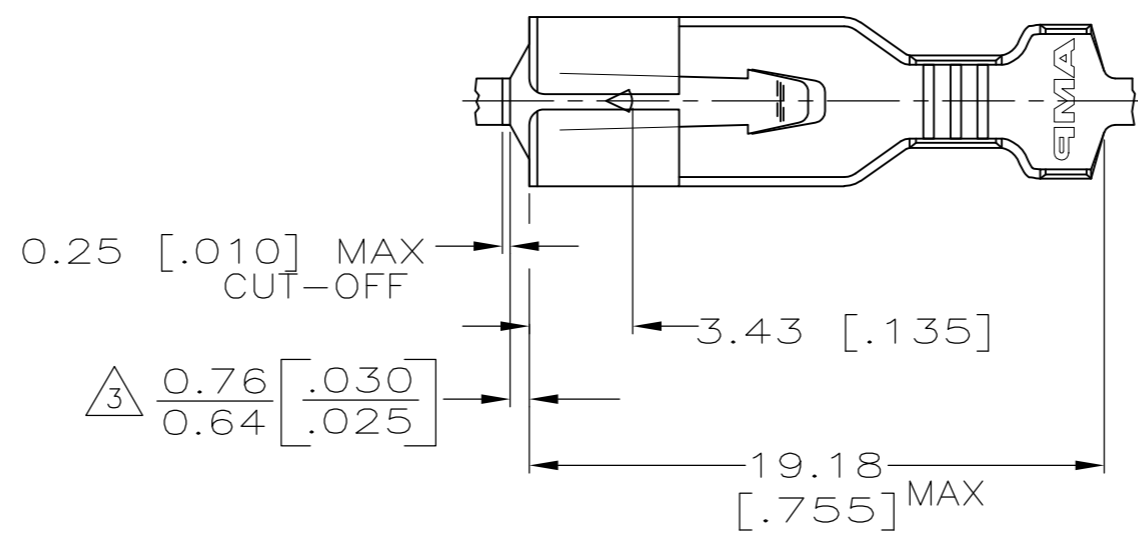

VIEW Y-Y  
 SCALE 10:1

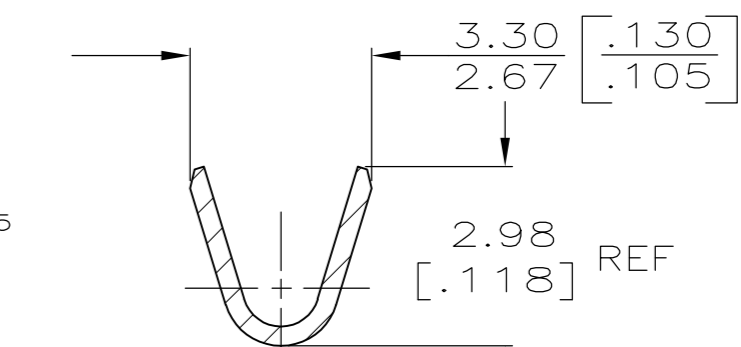

SECTION X-X  
 SCALE 8:1

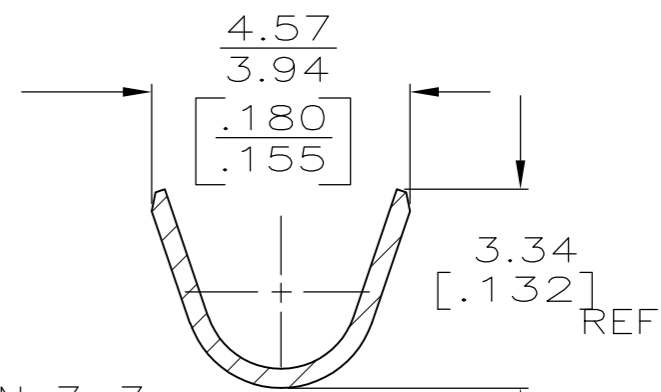

SECTION Z-Z  
 SCALE 8:1

OBSOLETE				63784-2
	F6DU14474CA	PRE-TIN	1.52-2.79 [.060-.110] DIA	[#20-#16] AWG
	FORD P/N	FINISH	INSULATION RANGE	WIRE SIZE
				PART NO

THIS DRAWING IS A CONTROLLED DOCUMENT.

DIMENSIONS: mm [INCHES]	TOLERANCES UNLESS OTHERWISE SPECIFIED: 0 PLC ± - 1 PLC ± - 2 PLC ± 0.25 [.010] 3 PLC ± - 4 PLC ± - ANGLES ± -	DWN JR RUTH 3/29/94 CHK MS FEHER 3/29/94 APVD J GILLESPIE 3/29/94 PRODUCT SPEC APPLICATION SPEC 114-2074 WEIGHT - CUSTOMER DRAWING	NAME RECEPTACLE, POSITIVE-LOCK, 4.75 [.187] SERIES SIZE A2 CAGE CODE 00779 DRAWING NO C=63784 RESTRICTED TO -
MATERIAL BRASS	FINISH SEE TABLE	SCALE 4:1	SHEET 1 OF 1

- 1 NOT FOR USE IN AMP HOUSINGS.
- 2 CONTINUOUS STRIP ON REELS.
- 3 THE 0.76[.030] / 0.64[.025] DIMENSION MUST BE MAINTAINED BY THE APPLICATOR CUT-OFF TO ENSURE THE PROPER LOCKING FUNCTION OF THE RECEPTACLE.
- 4 FORD P/N F6DU14474CA MARKED ON REEL LABEL.

单击下面可查看定价，库存，交付和生命周期等信息

[>>TE Connectivity\(泰科\)](#)